

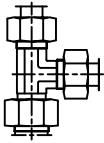

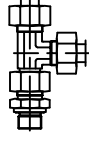

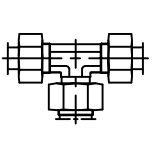
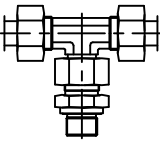
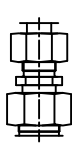
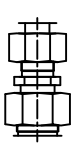
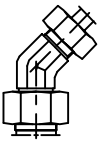

FIGURATIVE INDEX - FITTINGS DIN 2353 - ISO8434-1

General instructions	Quality assurance	Allowed temperatures	Finish treatments	Tube to be used	Threaded ends	Prescriptions to comply with
Utilization standards	Safety factors	Seals on threads	End treatments	Tables follow up	Gas - Metric UNF - NPT	Assembly instructions
Page 10 Type: F..	Page 11 Type: F4..	Page 12 Type: CN..	Page 13 Type: MSB..	Page 14-15 Type: MSM..	Page 16-21 Type: FSB..	Page 22-28 Type: MSU..
Page 30 Type: APC..	Page 30 Type: APCT..	Page 30 Type: MST..	Page 31-32 Type: MSN..	Page 33-34 Type: ECT..	Page 35 Type: ECN..	Page 36 Type: TEB..
Page 37-38 Type: TER..	Page 39 Type: SC..	Page 40 Type: BHC..	Page 41-42 Type: BHE..	Page 43 Type: EE..	Page 44 Type: ET	Page 45 Type: EC..
Page 46 Type: USC..	Page 47 Type: UET..	Page 47 Type: BHCR..	Page 48 Type: WC..	Page 48 Type: WBC..	Page 49 Type: WN..	Page 49 Type: WE..
Page 50 Type: MC..	Page 51 Type: AE..	Page 52 Type: AEU..	Page 52 Type: AE45B../AE45M..	Page 53 Type: AE45U..	Page 53 Type: ARTB../ARTM..	Page 54 Type: ARTU..
Page 54 Type: ATBB../ATBM...	Page 55 Type: ATBU..	Page 56 Type: BE..	Page 56-57 Type: RI..	Page 57 Type: RI..	Page 58 Type: AP..	Page 59 Type: AP..
Page 60 Type: BP..	Page 61 Type: B..	Page 61 Type: SW..	Page 62 Type: SW..	Page 62 Type: PL..	Page 63 Type: LN..	Page 63 Type: MSBW..
Page 64 Type: STP/M..	Page 64 Type: STUW..	Page 65 Type: STU..	Page 65 Type: STN..	Page 65 Type: GZ...	Page 65 Type: SE...	Page 66 Type: SEB../SEM..
Page 67-68	Page 69	Page 70	Page 70	Page 71-72	Page 73	Page 74

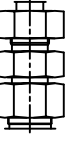
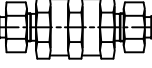
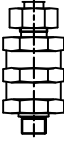
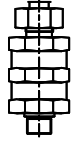
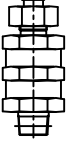
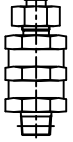
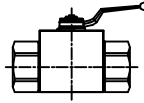
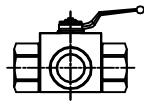
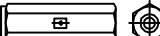
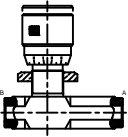
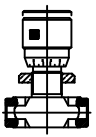
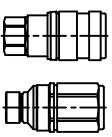
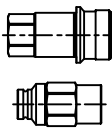
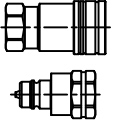
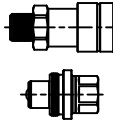
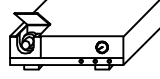
FIGURATIVE INDEX - FITTINGS DIN 2353 - ISO8434-1

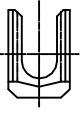
Type: TER.. 	Type: TER../TERM.. 	Type: TEB.. 	Type: TEB../TEBM.. 	Type: KOR.. 	Type: KOR.. 	Type: SE45.. 
Page 75	Page 76	Page 77	Page 78	Page 79	Page 80	Page 81
Type: GA.. 	Type: DA.. 	Type: NRV.. 	Type: NRV.. 	Type: NRV..E.. 	Type: NRV.. 	Type: NRV.. 
Page 81	Page 82	Page 82	Page 83	Page 84	Page 85	Page 86
Type: BV-2... 	Type: BV-3... 	Type: CV 	Type: TCV 	Type: TV 	Type: PLT1 	Type: PLT4 
Page 87-88	Page 89-90	Page 91	Page 92	Page 93	Page 94-97	Page 98-104
Type: PAV 	Type: PVS 	Type: 1013.. BSPP 	Type: 1015.. BSPP 	Type: 1017.. BSPT Type: 1018.. NPT 	Type: 1019.. Metric Paral. 	Type: 1020.. BSPT 
Page 105-108	Page 109-110	Page 2	Page 2	Page 2	Page 2	Page 2

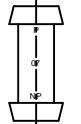
ASSEMBLY TOOLS DIN 2353 - ISO 8434-1

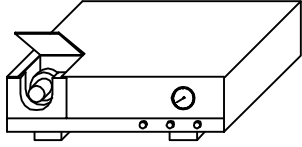
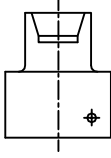
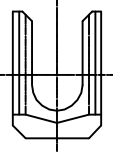
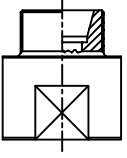
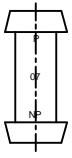
PREASSEMBLY MACHINE		MANDREL MACHINE	PLATFORM MACHINE	MANUL PREASSEMBLY TOOL	24° TOOL	
						
Series	ØTube	Ordering Machine	Ordering Mandrel	Ordering Platform	Ordering Preassembly	Ordering 24° tool
L	6	100000	100001	100021-83M	100061	204
	8		100002	100022-83M	100062	205
	10		100003	100023-83M	100063	206
	12		100004	100024-83M	100064	207
	15		100005	100025-83M	100065	208
	18		100006	100026-83M	100066	209
	22		100007	100027-83M	100067	210
	28		100008	100028-83M	100068	211
	35		100009	100029-83M	100069	212
	42		100010	100030-83M	100070	213
S	6	100000	100011	100031-83M	100071	204
	8		100012	100032-83M	100072	205
	10		100013	100033-83M	100073	206
	12		100014	100034-83M	100074	207
	14		100015	100035-83M	100075	214
	16		100016	100036-83M	100076	215
	20		100017	100037-83M	100077	216
	25		100018	100038-83M	100078	217
	30		100019	100039-83M	100079	218
	38		100020	100040-83M	100080	219

ORDERING EXAMPLES (Carbon steel)

ORDERING EXAMPLES (Stainless steel)

F STANDARD RING

- If you require a male stud coupling for a \varnothing 18mm tube with 1/2" BSP parallel thread made of carbon steel with standard ring, HF-MSB-18L-1/2

F STANDARD RING

- If you require a male stud coupling for a \varnothing 18mm tube with 1/2" BSP parallel thread made of stainless steel with standard ring, HF-MSB-18L-1/2-SS

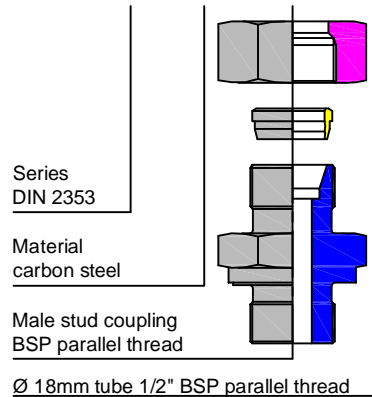

F4

- If you require a male stud coupling for a \varnothing 18mm tube with 1/2" BSP parallel thread made of carbon steel with elastomeric NBR seal on the threaded end, specify: HF-MSB-18L-1/2ED-F4
- * If you require the VITON seal, add "V" after the last fourth number HF-MSB-18L-1/2ED-F4-V

F4

- If you require a male stud coupling for a \varnothing 18mm tube with 1/2" BSP parallel thread made of stainless steel with elastomeric Viton seal on the threaded end, specify: HF-MSB-18L-1/2-ED-SS-V
- * If you require the NBR seal, add "N" after the last fourth number HF-MSB-18L-1/2ED-SS

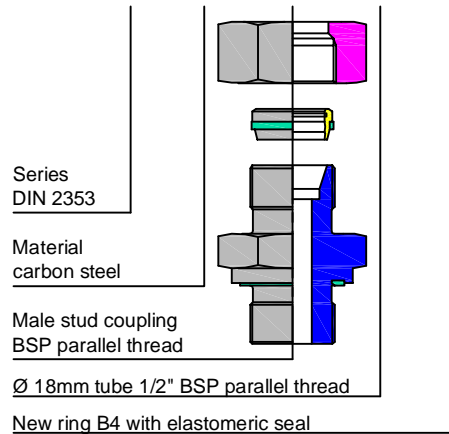

BODY FOR F-F4

- If you require the carbon steel body add BODY at the end of the fitting code to order: HF-MSB-18L-1/2ED-BODY

BODY FOR F-F4

- If you require the stainless steel body only, add BODY at the end of the fitting code to order: HF-MSB-18L-1/2ED-BODY

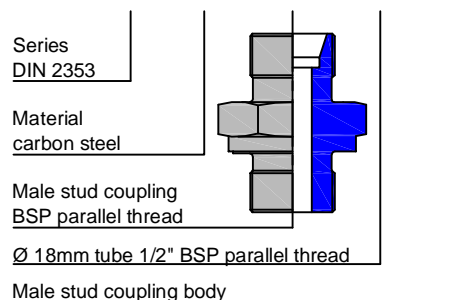

DELIVERIES

- HYFIT fittings are delivered in the configuration shown in the pictures of this catalogue.
- Available on scheduled orders only: it means that the article is slow moving and will be delivered within 30 days.
- Available on request only: it means that the article is not commonly in stock; please contact our offices for future delivery details.

VITON is a DuPont Dow Elastomers Trade Mark

THEORY OF OPERATION

The HYFIT fitting, manufactured according to ISO 8434-1/DIN 2353, is a mechanical fitting with a double cutting edge ring for double stapling on the tube.

The F ring helps fast assembly for removable tubes, avoid welding, tapping and flaring, thus assuring maximum simplicity for complex oleo-dynamic systems. During tightening by the nut, the ring deforms according to the bore of the 24° cone of the fitting and bites into the steel tube, producing two deep cuts the first of which is visible due to the lifting of an outer edge on the diameter of the tube, ensuring water tightness and anti-unthreading of the ring. The second groove (invisible) balances the forces on the whole ring, prevents vibrations from reaching the first groove and stops the stapling of the tube at a predetermined value.

COUPLING SYSTEM DIN 2353

Reference prescriptions:

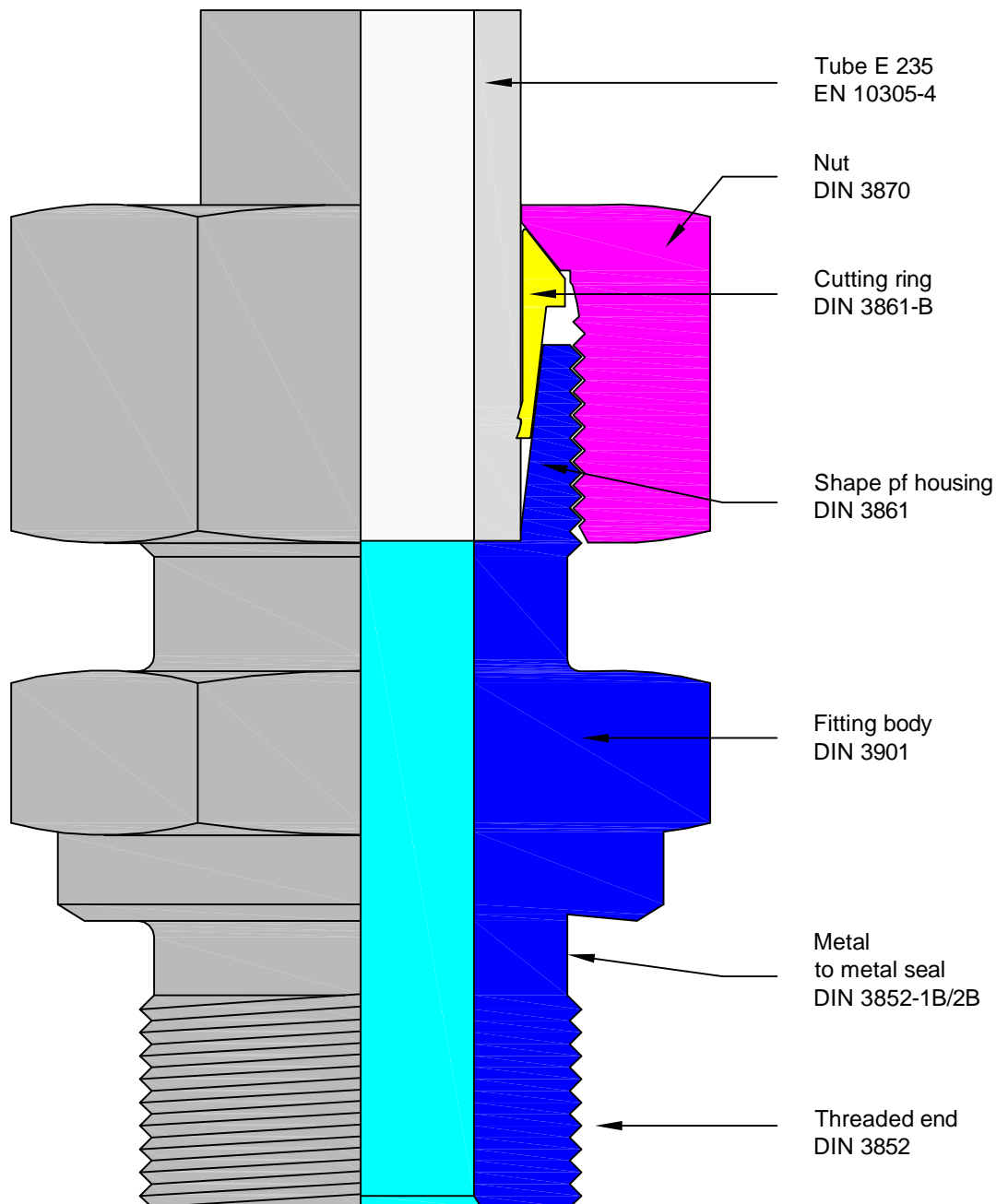

TECHNICAL CHARACTERISTICS

HYFIT fittings assure perfect seal regardless of the fluid used, provided that no corrosive fluids are employed and the nominal pressure be respected.

Fittings are manufactured in three ranges to be chosen according to the required working conditions.

The "LL" extra light range, suitable for low and medium working pressures up to 100 bars.

The "L" light duty series for applications characterised by medium high pressures of maximum 500 bars.

The "S" heavy duty series for harsh applications characterised by high temperatures and a maximum pressure of 800 bars.

Normal vibrations do not alter the fitting's performance. Which, even at maximum values, retains its characteristics of absolute reliability.

Before assembly on the metal tube

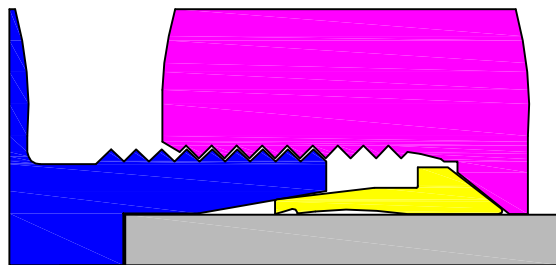

After assembly on the metal tube

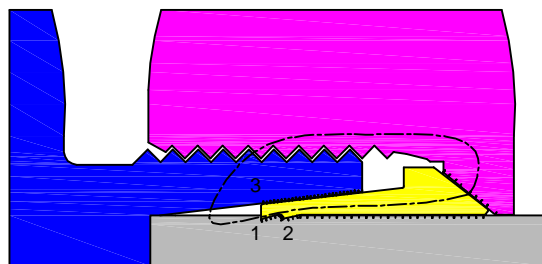

Field of force



Pressure surfaces



Sealing points 1 - 2 - 3

1 - 2 - 3

THEORY OF OPERATION

The HYFIT fitting, manufactured according to ISO 8434-1/DIN 2353, is a mechanical fitting with a double cutting edge ring for double stapling on the tube.

"F4" is a highly innovative, deformable, double clinching, double edge ring with double elastomer seal.

It is assembled according to well-known techniques and is perfectly interchangeable with all type of rings used on 24° cone fittings complying with ISO 8434-1/DIN 2353 standards.

The ring helps fast assembly of removable tubes, avoids welding, tapping and flaring, thus assuring maximum simplicity for complex oleo-dynamic system. During tightening by the nut, the ring deforms according to the bore of the 24° cone of the fitting and bites into the steel tube, producing two deep cuts, the first of which is visible due to the lifting of an outer edge on the diameter of the tube, ensuring water tightness and anti-unthreading of the ring.

The scord groove (invisible) balances the forces on the whole ring, prevents vibrations from reaching the first groove and stops the stapling of the tube at a predetermined value.

COUPLING SYSTEM DIN 2353

Reference prescriptions:

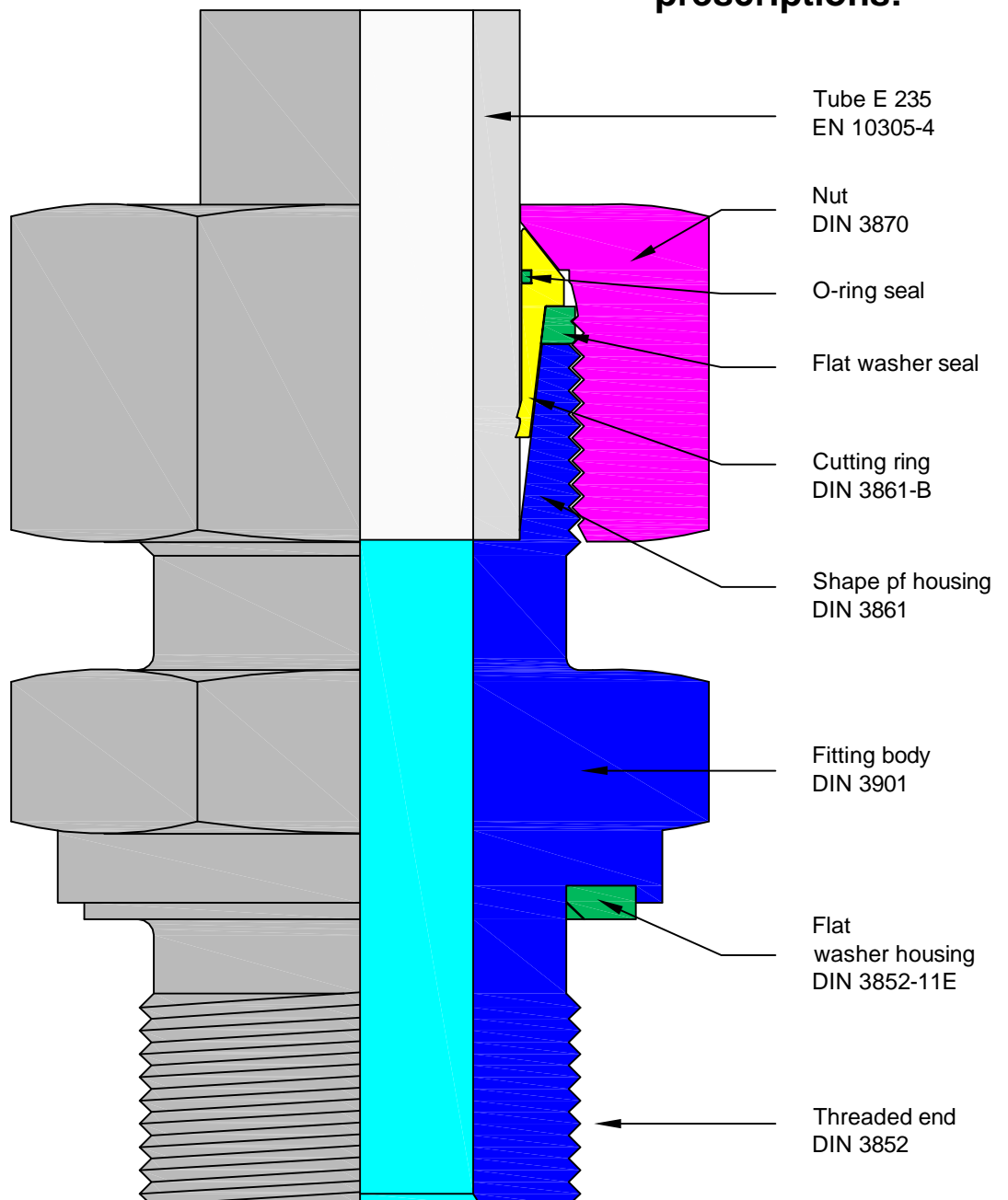

TECHNICAL CHARACTERISTICS

The "F4" ring assures perfect tightness of the circuit regardless of the fluid used, provided that corrosive fluids are avoided and nominal pressures of the fittings are complied with. The fittings on which the "B4" rings are mounted are manufactured in two series, which are used according to the operation conditions.

The "L" light duty series for application characterised by medium high pressures of maximum 500 bars.

The "S" heavy duty series for harsh applications characterised by high temperatures and a maximum pressure of 800 bars.

Normal vibrations do not alter the fitting's performance, which, even at maximum values, retains its characteristics of absolute reliability.

When the fittings, ring, nut, tube system is assembled, the flat seal is compressed between the head of the cutting ring and the front of the fitting body. The mechanical pressure applied to the flat seal causes flexure towards the outside, with a consequent increase in diameter. The deformation causes the compressed material of the seal to fill the turns of the thread of the nut free from the closing coupling with the fitting body, assuring locking of the nut and preventing any vibration-induced loosening of this.

When the fitting is disassembled with the tool and nut, the flat seal goes back to its original shape, without any damage, freeing the nut threads used previously, also allowing for the manual unscrewing of the same nut.

Before assembly on the metal tube

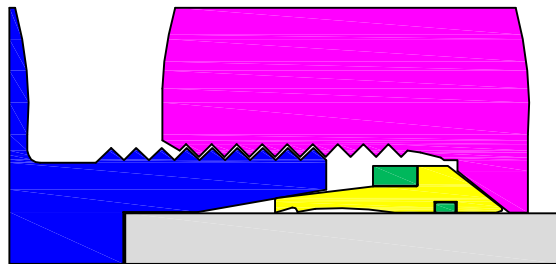

After assembly on the metal tube

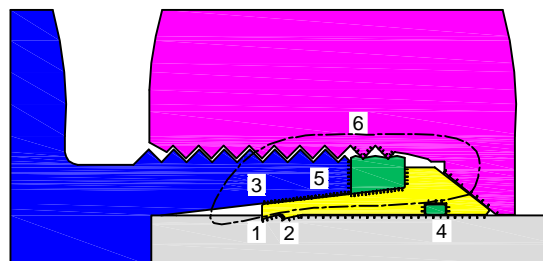

Field of force



Pressure surfaces



Sealing points 1 - 2 - 3

1 - 2 - 3

PRODUCT CONCEPT

The most original aspect of the product is that the structure of the existing ring has been used, inserting an O-Ring in the inside part to obtain another seal on the tube used; a flat seal has been used on the outer diameter to obtain two additional seals.

The main idea behind development of the "F4" was to design a new cutting ring able to go one step beyond the known techniques and solve the problem of minor losses of tightness, leaks, sweating and loosening of the system fastening nut. With this new ring, the double clinching of the seal tube is still possible, as well as, for obvious reasons of safety, the visual inspection of the correct coupling between the ring and the steel tube, maintaining the perfectly functional current system of assembly that is widely known to product users.

SEALING

"F4" solves the problem of absolute tightness in the following way:

- On the outer diameter of the steel tube, with the double cutting edges and with an O-Ring placed inside the ring that provides a first seal with an elastomeric material that did not exist before.
- In the 24° cone of the fitting body, with an increase in the metal-on-metal contact area and with a flat seal placed statically on the outer diameter of the cutting ring which, when compressed between the head of the ring and the front of the fitting body, provides a second seal with an elastomeric material that did not exist before.
- In the thread of the system fastening nut, with that flat seal, When this is compressed between the head of the ring and front of the fitting body, it fills the threads of the nut that are not engaged in clinching of the coupling system, thus providing a third seal with an elastomeric material that did not exist before.
- Basically, the "F4" provides six points of seal, of which three metal and three by means of two soft elastomeric seals (the flat seal assures two sealing points), thus obtaining a product that ensures complete tightness without any leakage risk, even in particularly harsh operating conditions.

**DEFINITION OF CONE SIZE TO DIN 3861 STANDARDS
 THREAD DIAMETERS TO DIN 3853 STANDARDS
 USED FOR F,F4 RINGS**

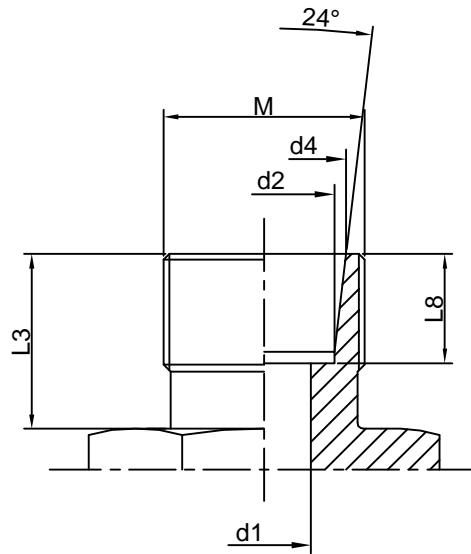

Series	W.P (Bar)	ØTube	Metric Thread	d1	d2	d4	L3	L8
LL	100	4	M8X1	3	4	5	8	4
		6	M10X1	4.5	6	7.5	8	5.5
		8	M12X1	6	8	9.5	9	5.5
L	250	6	M12X1.5	4	6	8.1	10	7
		8	M14X1.5	6	8	10.1	10	7
		10	M16X1.5	8	10	12.3	11	7
		12	M18X1.5	10	12	14.3	11	7
		15	M22X1.5	12	15	17.3	12	7
	160	18	M26X1.5	15	18	20.3	12	7.5
		22	M30X2	19	22	24.3	14	7.5
	100	28	M36X2	24	28	30.3	14	7.5
		35	M45X2	30	35	38	16	10.5
42		M52X2	36	42	45	16	11	
S	630	6	M14X1.5	4	6	8.1	12	7
		8	M16X1.5	5	8	10.1	12	7
		10	M18X1.5	7	10	12.3	12	7.5
		12	M20X1.5	8	12	14.3	12	7.5
		14	M22X1.5	10	14	16.3	14	8
	400	16	M24X1.5	12	16	18.3	14	8.5
		20	M30X2	16	20	22.9	16	10.5
		25	M36X2	20	25	27.9	18	12
	250	30	M42X2	25	30	33	20	13.5
		38	M52X2	30	38	41	22	16

GENERAL INSTRUCTIONS FOR F - F4 - ____ RINGS

- Before starting the pre-assembly make sure that piece of the machine and that hardened blocks are in perfect working order. Further inspections are necessary during the pre-assembly (every 30-50 tightening). For this purpose we recommend you to use a control buffer 1000... pierce and replace any block out of the tolerance.
- Over the whole tightening phase the tube must be in touch with the inner part of the body of the fitting. If this does not happen, the ring will advance with the tube without indenting it, making the coupling not functional and requiring the operation to be carried out again. The tube must not turn with the nut during the tightening phase; the capability of the ring to rotate, once the pre-assembly is done, is not a deficiency but rather a consequence of the right of the ring. Always check that the tube is correctly indented. If the indentation does not cover 80% of the cutting ring front side then the assembly is not functional and must be done again. Indicated pressures in the catalogue are for steel tubes only.
- In case thin wall tubes are used, specially mild tubes, mylon, Plastic, the assembling is possible, but a suitable reinforcement must be inserted into the end of the tube that is going to be tightened. Without the reinforcement it is not possible to operate with the materials mentioned above. In this case, carefully assess the working pressure.
- Before assembly the pre-assembled tube to the equipment it is necessary to check that the tube and the fitting are aligned. Fittings should never be used to correct a wrong alignment or to be a support for the tube. Extremely long tubes or tubes undergoing high stress must be fixed by using some support to avoid excessive vibrations. A poor alignment could damage the operation of the system.
- The proper lubrication of the components involved in the tightening is essential for good system operation. We advise the use of mineral oils or torque tension for carbon steel fittings, consisting of anti-seizing compound (Nickel based), Chesteron or similar, for stainless steel fitting.
- The fittings and the valves in this technical catalogue may be used for fluid-dynamic connections only. Indicated pressures in the catalogue are for steel tubes only.
- Mixing carbon and stainless steel components is allowed, but with prior approval.

UTILIZATION STANDARDS FOR F - F4 - ____

CARBON STEEL FITTINGS

- High quality tubes must be employed to assure correct use and related technical performance of the carbon steel fitting. The use of tubes without the aforementioned characteristics may seriously impair the efficiency of the fitting. We recommend using the following tubes only: calibrate, seamless, cold drawn and threaded tubes. Normalized with inert gas, made of material E235 according to EN10305-4 (ST 37.4 according to DIN 1630 I DIN 2391). The maximum hardness allowed on the outside diameter of the tube is 75 HRB.
- All carbon steel tubes with a diameter of more than 10 mm must be pre-assembled using the specific pre-assembly machine. If this is not available, hardened blocks, to be clamped in vice for manual pre-assembly, must be used. Remember to oil the thread, nut and ring. If hardened pre-assembly block are not available, normal straight fittings can be used. The fitting used once must be replaced at each tightening. During pre-assembly, pay special attention to parts such as reducing standpipes and nipples as these are made of raw materials characterized by higher resistance compared with the cuts made on annealed tube. These parts must always be pre-assembled on hardened or 24° cones (for all diameters).

STAINLESS STEEL FITTINGS

- High quality tubes must be employed to assure correct use and related technical performance of the stainless steel fittings. The use of tubes without the aforementioned characteristics may seriously impair the efficiency of the fitting. We recommend using the following tubes only: calibrated and polished, cold drawn seamless tubes 1.4571 as per UNI EN 10216-5 or ASTM A 269; the maximum permitted hardness, measured on the outer diameter of the tube, is 85 HRB Electrically welded tubes may be used, provided that these comply with the mechanical tolerances of the aforementioned standards and related hardness values for fittings compliant with SAE J514, BS 5200, SAE J1453.
- All stainless steel tubes must be pre-assembled using the specific pre-assembly machine. If this is not available, hardened block must be used for manual pre-assembly. In this case, make sure that the bench and vice in which the block is clamped are firmly fastened to prevent any possibility of movement caused by the twisting moment applied to the nut during the pre-assembly phase. Assembly operations directly on the stainless steel fitting are not allowed.

QUALITY ASSURANCE ACCORDING TO UNI EN ISO 9001:2015

The Quality Assurance System complies with UNI EN ISO 9001:2015.

HYFIT ENGINEERS has obtained the product homologation with the following registers:

METROLOGY-TEST LAB

A metrology lab equipped with state-of-the-art metallography microscopes, profile projectors, durometers, profilometers, micro-durometers, micro-meters, surface plates, comparators, buffers for various series of threads, etc., and a testing lab, equipped with three benches for static and dynamic tests, up to a pressure of 4000 bars, ensure the right tools for research, development, quality and safety control of our production. Highly trained specialised staff ensure that the technology is always up-to-date and that the knowledge and means are used in the best way possible, in compliance with the company's ethics.

COMPONENT TEST ON THE ENTIRE PRODUCT RANGE

A metrology lab equipped with state-of-the-art metallography microscopes, profile projectors, durometers, profilometers, micro-durometers, micro-meters, surface plates, comparators, buffers for various series of threads, etc., and a testing lab, equipped with three benches for static and dynamic tests, up to a pressure of 1200 bars, ensure the right tools for research, development, quality and safety control of our production. Highly trained specialised staff ensure that the technology is always up-to-date and that the knowledge and means are used in the best way possible, in compliance with the company's ethics.

SAFETY FACTORS

"F", "F4" rings provide the right answer to safety problems so that absolute functional reliability between the ring, the steel tube and the fitting body is guaranteed by the double clinching and automatic locking of the cuts on the steel tube (assured by the particular shape of the ring). If on one side we increase the safe fastening, on the other we set a precise mechanical limit at the cutting of the tube, with the certainty of correct function.

- The nominal working pressures (bar) given in the catalogue indicate the maximum permissible pressures (including pressure peaks). For higher pressure the items must be tested in accordance with the manufacturer for specific applications.
- The safety factor is 4:1 and is intended with static load and with the temperature at the values indicated in the HYFIT ENGINEERS Catalogue for tube connection. The same safety factor 4:1 is intended for parallel threaded end fittings with elastomeric seal.
- For stud coupling with taper or parallel threaded end fittings with metal to metal seal, the safety factor is 2.5:1.
- It is understood that the product is guaranteed only if the full connection is made entirely with our products and components.

GENERAL INFORMATION

● STEEL USED ON ALL SERIES

With a view to R&D and continuous improvement, our company has examined the issues of best usage of the raw material for the creation of our product. The steels used are all of the finest quality and are exclusively purchased from leading steel manufacturer. All the batches used have testing documentation 3.1 reporting the number of heat as well as the chemical characteristics and mechanical characteristics. The above applies to carbon steel and stainless steel. The reference standards for the raw material normally used before are in line with the following principles: UNI EN 10087, UNI EN 10083-2, UNI EN 10025, UNI EN 10088-3 and so on.

● ALLOWED STEEL TEMPERATURE

Carbon Steel -40°C to 120°C, according to ISO 8434

Stainless Steel -60°C to +200°C, according to ISO 8434

● PRESSURE REDUCTIONS

The allowed working pressure for stainless steel fittings manufactured with 1.4571 must be reduced according to the working temperature registered as per ISO 8434.

In case of multi-components systems all the parameters must be calculated on the weakest component used.

Type of steel	Working Temperature	Lowering percentage
1.4571	≥ 50°C	- 4%
1.4571	≥ 100°C	- 11%
1.4571	≥ 200°C	- 20%

● GASKETS AND O-RINGS

The gasket and o-rings used on valves and fittings are normally manufactured in NBR and have a working temperature of -35°C and +100°C. For higher temperatures VITON gaskets and o-rings are suggested with working temperatures between -25°C and +200°C.

The gasket made of NBR used in the valves and for the end seals have a hardness of 85 ±5 shores, while those in VITON have a hardness of 80 ±5 shores.

The o-rings made of NBR and VITON have a hardness of 80±5 shores, except for those used on the tube side seal of the ORFS fittings, which have a hardness of 90±5 shores.

The gaskets and o-rings, just like the products they are assembled on, must be managed according to DIN 7716 (requisites for the stocking of rubber and India rubber products).

● SEALS ON THREADED ENDS

To obtain the maximum performance, the taper male thread is to be matched with the taper female thread. The cylindrical male thread is to be matched with the cylindrical female thread. It is possible to match a taper male thread with a cylindrical female thread, but this combination is technically valid only in pipings where medium/low performance is required, and is never to be used where high pressure are applied. In case of matching of a cylindrical thread with relatively soft material, it is advisable to use the plain gasket type of seal that guarantees a perfect seal even with a relatively low tightening torque.

● CARBON STEEL FITTINGS FINISH TREATMENT

All HYFIT ENGINEERS fittings, valves and components undergo surface treatment protection of the type: Zinc plating Fe/Zn 7 IV-Fe/Zn8 b/c 1 B UNI ISO 2081-4520, plus top coat, equivalent to a Cathodic electrolytic zinc-plating with trivalent chromium. The fitting acts as a cathode (negative), the zinc which is deposited thickness is around 8+12 µm.

To be able to reach the resistance of 400 hours ±15% to white salt and 750 hours ±15% to red salt, a top coat is applied which, in addition to guaranteeing the required performance, facilitates assembly.

The top coat has the task of filling all the micro cavities in the zinc-plating treatment, which represent an initial part of the corrosion outbreaks. By sealing these micro defects, the zinc-plating treatment significantly improves its protective performance to the values indicates previously. The resistance to corrosion of this new type of zing-plating notably increases compared to the previous one. The appearance has a silver colour with yellow shades.

It complies with current International environmental laws on hazardous waste and with the European EVL standard as it uses trivalent chromium (chIII), in compliance with local laws protecting the health of people and the precautionary principle of protecting our environment.

The zinc-plating will be identified by reading the traceability codes of the year of production, starting from 2013. The new zinc-plating applies from this date onwards.

● STAINLESS STEEL FITTINGS FINISH TREATMENT

All the fittings and valves are treated with a chemical cleaning process that eliminates all oxides and burrs due to the machining phase, without altering or damaging the product. after this, a bath cleans the product and takes away any residual impurities. The piece at the end of the treatment looks really bright, prefect for oleo-dynamic industrial applications.

● THERMAL TREATMENTS FOR STAINLESS STEEL RINGS

After being machined, the rings are heat treated to harden the surface. This type of treatment, on stainless steel cutting rings, may decrease the amagnetivity of the ring itself. A slight amagnetivity is therefore inevitable and does not indicate a defect.

● ANTI-POLLUTION TREATMENT

- HYFIT ENGINEERS with a view to "Continuous Improvement" has implemented an operating system to avoid contamination from dust or working residues occurring inside its production facilities, which may in some way jeopardise the function of the component and damage the actuators (valves, cylinder, etc) from the entire circuit.

- In short, all of HYFIT ENGINEERS fittings, after various checks and treatments during the entire production cycle, undergo a last process/check to cancel the micro bubbles on the threads, insert any o-rings or gaskets, clean dust, burrs or processing dross and cap the component to maintain the result obtained with these operations until the use.

● CARBON STEEL TUBES ALLOWED ON ALL SERIES

- For carbon steel tubes we advise using calibrated seamless cold drawn tubes, normalised with inert gas, in E235 material according to EN 10305-4 (ST 37.4 according to DIN 1630 I DIN 2391).
- Maximum allowed hardness on the outside diameter of the tube is 75HRB.
- The pressures stated in the table below are generally intended at a constant rate and with temperatures ranging between -40°C and +120°C.

Ø Tube mm	Tolerance EN 10305-4 mm	Thickness mm	Static DIN 2413-1 pressure bar	Dynammic DIN 2413-III pressure bar	Weight Kg/m
4	± 0.1	0.5	313	274	0.047
4		1	522	502	0.075
6	± 0.1	1	389	374	0.123
6		1.5	549	528	0.166
6		2	692	665	0.197
8	± 0.1	1	333	289	0.222
8		1.5	431	441	0.240
8		2	549	528	0.296
8		2.5	658	632	0.339
10	± 0.1	1	282	249	0.222
10		1.5	373	358	0.314
10		2	478	460	0.395
10		2.5	576	553	0.462
10		3	666	641	0.518
12	± 0.08	1	235	210	0.271
12		1.5	353	305	0.388
12		2	409	393	0.493
12		2.5	495	476	0.586
12		3	576	553	0.66
12		3.5	651	627	0.734
14	± 0.08	1.5	302	265	0.462
14		2	403	343	0.592
14		2.5	434	417	0.709
14		3	507	487	0.814
14		3.5	576	553	0.906
15	± 0.08	1.5	282	249	0.499
15		2	376	323	0.641
15		2.5	409	393	0.771
15		3	478	460	0.888
16	± 0.08	1	176	161	0.370
16		1.5	264	234	0.536
16		2	353	305	0.691
16		2.5	386	372	0.832
16		3	452	435	0.962
18	± 0.08	1	157	143	0.419
18		1.5	235	210	0.610
18		2	313	274	0.789
18		2.5	392	335	0.956
18		3	409	393	1.111
18		4	522	502	1.381

Ø Tube mm	Tolerance EN 10305-4 mm	Thickness mm	Static DIN 2413-1 pressure bar	Dynammic DIN 2413-III pressure bar	Weight Kg/m
20	± 0.08	2	282	249	0.888
20		2.5	353	305	1.079
20		3	373	358	1.258
20		3.5	426	410	1.424
20		4	478	460	1.578
22	± 0.08	1.5	192	174	0.758
22		2	256	228	0.986
22		2.5	320	280	1.202
22		3	385	329	1.406
22		4	441	424	1.766
22		5	532	512	2.367
25	± 0.08	2	226	202	1.134
25		2.5	282	249	1.387
25		3	338	294	1.628
25		4	394	379	2.072
25		4.5	437	420	2.275
25		5	478	460	2.466
28	± 0.08	2	201	182	1.282
28		2.5	252	224	1.572
28		3	302	265	1.850
28		4	403	343	2.368
28		5	434	417	2.836
30	± 0.08	2	168	171	1.381
30		2.5	235	210	1.695
30		3	282	249	1.998
30		4	376	323	2.565
30		5	409	393	3.083
32	± 0.15	3	265	235	2.146
32		4	353	305	2.762
32		5	387	372	3.329
35	± 0.15	2	161	147	2.189
35		2.5	201	182	2.004
35		3	242	216	2.367
35		4	322	281	3.058
38	± 0.15	3	223	200	2.589
38		4	297	261	3.354
38		5	371	319	4.069
42	± 0.2 (4)	3	201	182	2.885
42		4	269	238	3.749

CALCULATION PRESSURES

The calculation of the pressure with static load is made to DIN 2413-1 with yield point K=235N/mm².

For tubes with an external/internal diameter ratio > 1.35, calculation is made to DIN 2413-III but with yield point K=235N/mm².

The calculation of the pressure with dynamic stress is made to DIN 2413-III with permanent fatigue strength K=226N/mm².

Safety factor S=1.5

Allowance factor c=0.8 for 4mm Øtube, c=.85 for 6-8mm Øtube, c=0.9 for >8mm Øtube

Corrosion: no additional allowance is considered for pressure calculations.

● STAINLESS STEEL TUBES ALLOWED ON ALL SERIES

- For stainless steel tubes we advise using calibrated and polished, seamless, cold drawn tubes in material 1.457 as per UNI EN10216-5 or ASTM
- Maximum allowed duration on the outside diameter of the tube is 85 HRB.
- The pressures stated in the table below are generally intended at a constant rate and with temperatures ranging between -60°C and +120°C.

Ø Tube mm	Tolerance EN 10305-4 mm	Thickness mm	Static DIN 2413-1 pressure bar	Weight Kg/m
4	± 0.1	0.5	326	0.048
4		1	544	0.076
6	± 0.1	1	406	0.125
6		1.5	572	0.169
6		2	721	0.200
8	± 0.1	1	347	0.225
8		1.5	449	0.244
8		2	572	0.301
8		2.5	686	0.344
10	± 0.1	1	294	0.225
10		1.5	389	0.319
10		2	498	0.401
10		2.5	601	0.469
10		3	694	0.526
12	± 0.08	1	245	0.275
12		1.5	368	0.394
12		2	426	0.500
12		2.5	516	0.595
12		3	601	0.676
12		3.5	679	0.745
14	± 0.08	1.5	315	0.469
14		2	420	0.601
14		2.5	452	0.720
14		3	529	0.826
14	± 0.08	3.5	601	0.920
15		1.5	294	0.507
15		2	392	0.651
15	± 0.08	2.5	426	0.782
15		3	498	0.902
16		1	183	0.373
16	± 0.08	1.5	275	0.544
16		2	368	0.702
16		2.5	402	0.845
16		3	471	0.977
18	± 0.08	1	163	0.423
18		1.5	245	0.619
18		2	326	0.801
18		2.5	409	0.971
18		3	426	1.128
18		4	544	1.401

Ø Tube mm	Tolerance EN 10305-4 mm	Thickness mm	Static DIN 2413-1 pressure bar	Weight Kg/m
20	± 0.08	2	294	0.902
20		2.5	368	1.095
20		3	389	1.277
20		3.5	444	1.446
20		4	498	1.602
22	± 0.08	1.5	200	0.764
22		2	267	1.001
22		2.5	334	1.220
22		3	401	1.427
22		4	459	1.802
22	± 0.08	5	555	2.402
25		2	236	1.151
25		2.5	294	1.408
25		3	352	1.653
25		4	411	2.104
25	± 0.08	4.5	456	2.310
25		5	498	2.490
28		2	210	1.301
28		2.5	263	1.596
28		3	315	1.878
28	± 0.08	4	420	2.403
28		5	452	2.878
30		2	175	1.402
30	± 0.08	2.5	245	1.721
30		3	294	2.028
30		4	392	2.604
30		5	426	3.110
32	± 0.15	3	275	2.177
32		4	368	2.803
32		5	403	3.378
35	± 0.15	2	168	2.222
35		2.5	210	2.034
35		3	252	2.403
35		4	336	3.104
38	± 0.15	3	232	2.628
38		4	310	3.405
38		5	387	4.131
42	± 0.2	3	210	2.929
42		4	280	3.806

CALCULATION PRESSURES

The calculation of the pressure with static load is made to DIN 2413-1 with yield point $K=245N/mm^2$.
 For tubes with an external/internal diameter ratio >1.35 , calculation is made to DIN 2413-III but with yield point $K=245N/mm^2$.
 Pressures with dynamic stress according to DIN 2413-111 are not listed because in EN 10216-5 the permanent fatigue stress K is also not listed.
 We recommend, for calculation in accordance to DIN 2413-111, to assume a value $K=190N/mm^2$.
 Safety factor $S=1.5$
 Allowance factor $c=0.9$
 Corrosion: no additional allowance is considered for pressure calculations.

- The insufficient thickness of the tube walls, or the too low longitudinal resistance of the tube (particularly mild soft steel) may result in problems with the cutting, with relevant loss of seal and a drastic decrease in the safety factor. This aspect must be considered when choosing the tube. it is a good rule to pick tubes that make it so that the internal flare (decreasing of the internal diameter) does not exceed 3/10 of a millimeter up to an outer diameter of 16mm and 4/10 of a millimeter for greater diameter.

STUD ENDS WITH BSPP THREAD

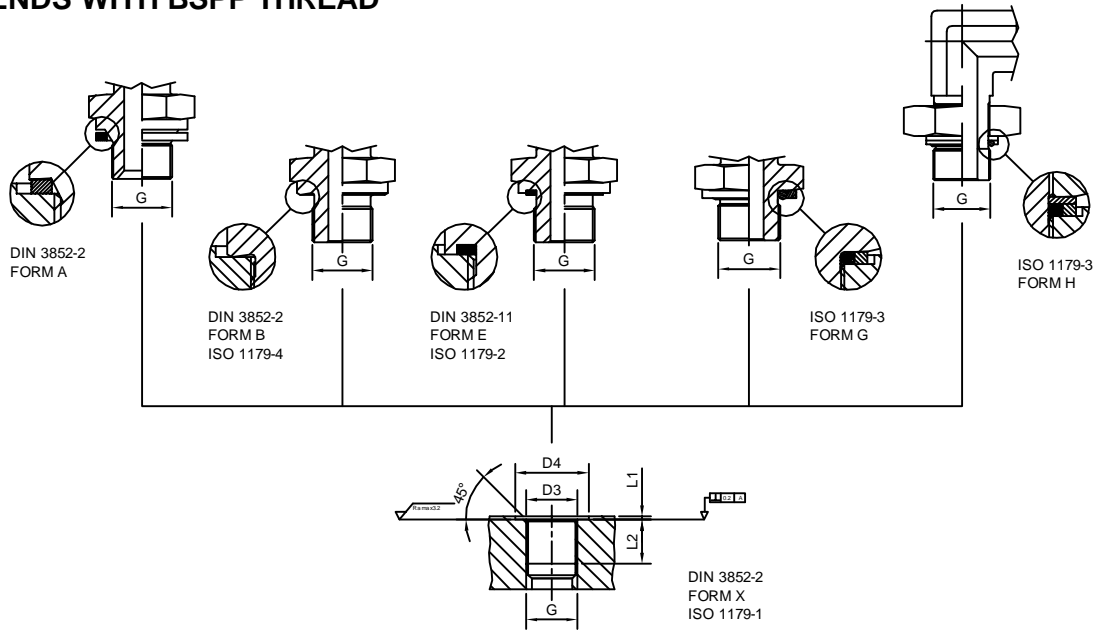

Series	Ø Tube	Thread Gas	D3	D4 min		L1 max	L2 min	L ref	from A	from B	from E	from E (caps 078..)	from G	from G (caps 078..)	from H
				from A/B/E	from G/H										
L	6	G 1/8	9.8	15	17.2	1	8	7.5	-	20	20	10	20	10	20
	8-10	G 1/4	13.2	20	20.7	1.5	12	10.2	-	45	45	25	45	25	45
	12	G 3/8	16.7	23	24.5	2	12	10.4	-	70	70	40	70	40	70
	15-18	G 1/2	21	28	29.6	2.5	14	13.1	-	130	85	75	85	75	85
	22	G 3/4	26.5	33	36.9	2.5	16	13.5	-	170	170	120	170	120	170
	28	G 1	33.3	41	46.1	2.5	18	14.7	-	330	330	230	330	230	330
	35	G 1 1/4	42	51	54	2.5	20	14.7	-	510	430	300	430	300	430
S	42	G 1 1/2	47.9	56	60.5	2.5	22	14.7	-	600	510	360	510	360	510
	6-8	G 1/4	13.2	20	20.7	1.5	12	10.2	-	55	55	25	55	25	55
	10-12	G 3/8	16.7	23	24.5	2	12	10.4	-	85	80	40	80	40	80
	14-16	G 1/2	21	28	29.6	2.5	14	13.1	-	150	110	75	110	75	110
	20	G 3/4	26.5	33	36.9	2.5	16	13.5	-	280	170	120	170	120	170
	25	G 1	33.3	41	46.1	2.5	18	14.7	-	330	330	230	330	230	330
	30	G 1 1/4	42	51	54	2.5	20	14.7	-	510	430	300	430	300	430
JIC 37° - BS 5200	38	G 1 1/2	47.9	56	60.5	2.5	22	14.7	-	680	510	360	510	360	510
	6	G 1/8	9.8	15	17.2	1	8	7.5	20	-	20	-	20	-	20
	8-10	G 1/4	13.2	20	20.7	1.5	12	10.2	35	-	45	-	45	-	45
	12	G 3/8	16.7	23	24.5	2	12	10.4	70	-	70	-	70	-	70
	14-15-16	G 1/2	21	28	29.6	2.5	14	13.1	85	-	85	-	85	-	80
	-	G 5/8	23	31	-	2.5	16	-	105	-	-	-	-	-	-
	18-20	G 3/4	26.5	33	36.9	2.5	16	13.5	120	-	170	-	170	-	170
ORFS	25	G 1	33.3	41	46.1	2.5	18	14.7	180	-	330	-	330	-	330
	30-32	G 1 1/4	42	51	54	2.5	20	14.7	260	-	430	-	430	-	430
	38	G 1 1/2	47.9	56	60.5	2.5	22	14.7	290	-	510	-	510	-	510
	-	G 2	59.7	69	73.3	3	24	-	380	-	640	-	640	-	640
	6	G 1/8	9.8	15	17.2	1	8	7.5	-	-	20	-	20	-	20
	8-10	G 1/4	13.2	20	20.7	1.5	12	10.2	-	-	55	-	55	-	55
	12	G 3/8	16.7	23	24.5	2	12	10.4	-	-	80	-	80	-	80
14-15-16	G 1/2	21	28	29.6	2.5	14	13.1	-	-	110	-	110	-	110	
18-20	G 3/4	26.5	33	36.9	2.5	16	13.5	-	-	170	-	170	-	170	
22-25	G 1	33.3	41	46.1	2.5	18	14.7	-	-	330	-	330	-	330	
28-30-32	G 1 1/4	42	51	54	2.5	20	14.7	-	-	430	-	430	-	430	
35-38	G 1 1/2	47.9	56	60.5	2.5	22	14.7	-	-	510	-	510	-	510	

Performance:	Sealing form A:	Sealing from B:	Sealing form E:	Sealing form G:	Sealing form H:
-pressure capacity	good	good	excellent	excellent	excellent
-sealing characteristics	good	good	excellent	excellent	excellent
-additional sealing required	no	no	no	no	no
-safety factor	2,5:1	2,5:1	4:1	4:1	4:1

Notes: The values in the tightening tables are approximate, which may vary based on the materials and tolerances of the components used.

STUD ENDS WITH METRIC THREAD

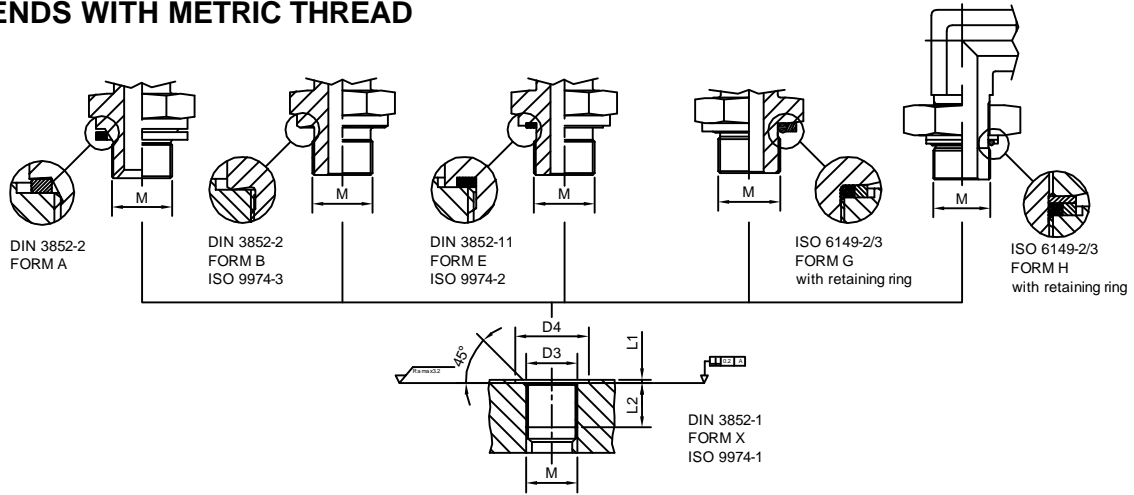

Series	Ø Tube	Thread Gas	D3	D4 min		L1	L2	L	from A	from B	from E	from E (caps 078..)	from G	from G (caps 078..)	from H	
				from A/B/E	from G/H	max	min	ref								
L	6	M10x1	10	15	16	1	8	7.6	-	20	20	10	20	10	20	
	8	M12x1.5	12	18	19	1.5	12	9.7	-	30	30	20	30	20	30	
	10	M14x1.5	14	20	21	1.5	12	9.7	-	45	45	35	50	35	50	
	12	M16x1.5	16	23	24	1.5	12	10.2	-	60	55	40	55	40	55	
	15	M18x1.5	18	25	26	2	12	10.9	-	80	70	45	70	45	70	
	18	M22x1.5	22	28	29	2.5	14	12	-	130	120	90	120	90	120	
	22	M26x1.5	26	33	-	2.5	16	-	-	180	170	120	-	120	-	
22	M27x2	27	33	35	2.5	16	13.8	-	-	-	120	170	120	170		
S	28	M10x1	33	41	43	2.5	18	13.8	-	330	330	230	330	230	330	
	35	M10x1	42	51	52	2.5	20	13.8	-	470	430	300	430	300	430	
	42	M10x1	48	56	57	2.5	22	15.3	-	600	510	360	510	360	510	
	6	M10x1	12	18	19	1.5	12	9.7	-	40	40	20	40	20	40	
	8	M10x1	14	20	21	1.5	12	9.7	-	55	55	35	55	35	55	
	10	M10x1	16	23	24	1.5	12	10.2	-	80	70	40	70	40	70	
JIC 37° - BS 5200	12	M10x1	18	25	26	2	12	10.9	-	1051	85	45	85	45	85	
	14	M10x1	20	27	28	2	14	12	-	50	120	85	120	85	120	
	16	M10x1	22	28	29	2.5	14	12	-	170	130	90	130	90	130	
	20	M10x1	27	33	35	2.5	16	13.8	-	200	170	120	170	120	170	
	25	M10x1	33	41	43	2.5	18	13.8	-	390	330	230	330	230	330	
	30	M10x1	42	51	52	2.5	20	13.8	-	510	430	300	430	300	430	
	38	M10x1	48	56	57	2.5	22	15.3	-	680	510	360	510	360	510	
	6	M10x1	10	15	16	1	8	7.6	20	-	20	-	20	-	20	-
	8	M10x1	12	18	19	1.5	12	9.7	30	-	30	-	30	-	30	-
	10	M10x1	14	20	21	1.5	12	9.7	45	-	45	-	45	-	45	-
ORFS	12	M10x1	16	23	24	1.5	12	10.2	60	-	55	-	55	-	55	
	14-15-16	M10x1	18	25	26	2	12	10.9	80	-	70	-	70	-	70	
	14-15-16	M10x1	20	27	28	2	14	12	105	-	105	-	105	-	105	
	14-15-16	M10x1	22	28	29	2.5	14	12	130	-	120	-	120	-	120	
	-	M10x1	26	33	-	2.5	16	-	160	-	-	-	-	-	-	
	18-20	M10x1	27	33	35	2.5	16	13.8	-	-	170	-	170	-	170	
	-	M10x1	30	37	-	2.5	-	-	190	-	-	-	-	-	-	
	22-25	M10x1	33	41	43	2.5	18	13.8	-	-	330	-	330	-	330	
	-	M10x1	38	45	-	2.5	-	-	230	-	-	-	-	-	-	
	28-30-32	-	42	51	52	2.5	20	13.8	-	-	430	-	430	-	430	
-	-	45	53	-	2.5	-	-	280	-	-	-	-	-	-		
35-38	-	48	56	57	2.5	22	15.3	-	-	510	-	510	-	510		
6	-	10	15	16	1	8	8.6	-	-	20	-	20	-	20		
8-10	-	12	18	19	1.5	12	9.7	-	-	40	-	40	-	40		
8-10	-	14	20	21	1.5	12	9.7	-	-	55	-	55	-	55		
12	-	16	23	24	1.5	12	11.2	-	-	70	-	70	-	70		
14-15-16	-	18	25	26	2	12	12.4	-	-	85	-	85	-	85		
14-15-16	-	22	28	29	2.5	14	14	-	-	130	-	130	-	130		
18-20	-	27	33	35	2.5	16	16.3	-	-	170	-	170	-	170		
22-25	-	33	41	43	2.5	18	16.3	-	-	330	-	330	-	330		
28-30-32	-	42	51	52	2.5	20	16.8	-	-	430	-	430	-	430		
35-38	-	48	56	57	2.5	22	19.3	-	-	510	-	510	-	510		

Performance:	Sealing form A:	Sealing from B:	Sealing form E:	Sealing form G:	Sealing form H:
-pressure capacity	good	good	excellent	excellent	excellent
-sealing characteristics	good	good	excellent	excellent	excellent
-additional sealing required	no	no	no	no	no
-safety factor	2,5:1	2,5:1	4:1	4:1	4:1

Notes: The values in the tightening tables are approximate, which may vary based on the materials and tolerances of the components used.

STUD ENDS WITH METRIC THREAD (ISO 6149)

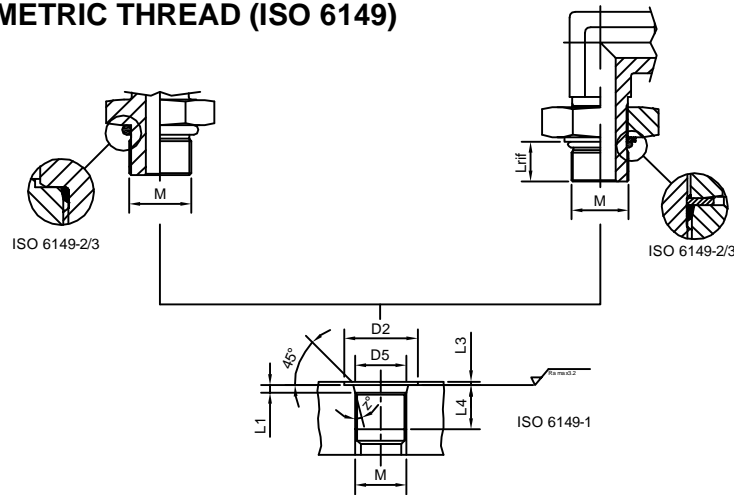

Series	ISO 6149 STRAIGHT	ISO 6149 SWIVEL	ØTube	Metric Thread	D2	D5	L1	L3 max	L4 min	L rif	Z°	ISO 6149 STRAIGHT	ISO 6149 SWIVEL
L	315	315	6	M10x1	16	11.1	1.6	1	10	8.6	12	15	15
	315	315	8	M12x1.5	19	13.8	2.4	1.5	11.5	11.1	15	25	25
	315	315	10	M14x1.5	21	15.8	2.4	1.5	11.5	11.1	15	30	30
	315	250	12	M16x1.5	24	17.8	2.4	1.5	13	11.6	15	35	35
	315	250	15	M18x1.5	26	19.8	2.4	2	14.5	12.3	15	40	40
	315	250	18	M22x1.5	29	23.8	2.4	2	15.5	13.4	15	55	55
	160	160	22	M27x2	34	29.4	3.1	2	19	15.8	15	85	85
	160	160	28	M33x2	43	35.4	3.1	2.5	19	15.8	15	140	140
	160	160	35	M42x2	52	44.4	3.1	2.5	19.5	15.8	15	180	180
160	160	42	M48x2	57	50.4	3.1	2.5	22	17.3	15	230	230	
S	630	400	6	M12x1.5	19	13.8	2.4	1.5	11.5	11.1	15	30	30
	630	400	8	M14x1.5	21	15.8	2.4	1.5	11.5	11.1	15	40	40
	630	400	10	M16x1.5	24	17.8	2.4	1.5	13	11.6	15	50	50
	630	400	12	M18x1.5	26	19.8	2.4	2	14.5	12.3	15	60	60
	400	400	14	M20x1.5	27	21.8	2.4	2	14.5	13.4	15	70	70
	400	400	16	M22x1.5	29	23.8	2.4	2	15.5	13.4	15	85	85
	400	400	20	M27x2	34	29.4	3.1	2	19	15.8	15	150	150
	400	315	25	M33x2	43	35.4	3.1	2.5	19	15.8	15	260	260
	250	250	30	M42x2	52	44.4	3.1	2.5	19.5	15.8	15	280	280
250	200	38	M48x2	57	50.4	3.1	2.5	22	17.3	15	360	360	
400	315	6	M10x1	16	11.1	1.6	1	10	8.6	12	15	15	
400	315	8-10	M12x1.5	19	13.8	2.4	1.5	11.5	11.1	15	25	25	
350	315	8-10	M14x1.5	21	15.8	2.4	1.5	11.5	11.1	15	30	30	
315	250	12	M16x1.5	24	17.8	2.4	1.5	13	11.6	15	35	35	
315	250	14-15-16	M18x1.5	26	19.8	2.4	2	14.5	12.3	15	40	40	
315	250	14-15-16	M20x1.5	27	21.8	2.4	2	14.5	13.4	15	50	50	
315	160	14-15-16	M22x1.5	29	23.8	2.4	2	15.5	13.4	15	55	55	
200	160	18-20	M27x2	34	29.4	3.1	2	19	15.8	15	85	85	
200	160	22-25	M33x2	43	35.4	3.1	2.5	19	15.8	15	140	140	
200	160	28-30-32	M42x2	52	44.4	3.1	2.5	19.5	15.8	15	180	180	
200	400	35-38	M48x2	57	50.4	3.1	2.5	22	17.3	15	230	230	
ORFS	630	400	6	M10x1	16	11.1	1.6	1	10	9.6	12	15	15
	630	400	8-10	M12x1.5	19	13.8	2.4	1.5	11.5	11.1	15	30	30
	630	400	8-10	M14x1.5	21	15.8	2.4	1.5	11.5	11.1	15	40	40
	630	400	12	M16x1.5	24	17.8	2.4	1.5	13	12.6	15	50	50
	630	400	14-15-16	M18x1.5	26	19.8	2.4	2	14.5	12.3	15	60	60
	400	400	14-15-16	M22x1.5	29	23.8	2.4	2	15.5	15.4	15	85	85
	400	400	18-20	M27x2	34	29.4	3.1	2	19	18.3	15	150	150
	400	315	22-25	M33x2	43	35.4	3.1	2.5	19	18.3	15	260	260
	250	250	28-30-32	M42x2	52	44.4	3.1	2.5	19.5	18.8	15	280	280
250	250	35-38	M48x2	57	50.4	3.1	2.5	22	21.3	15	360	360	

Performance:

-pressure capacity
 -sealing characteristics
 -additional sealing required
 -safety factor

Seal STRAIGHT:

excellent
 excellent
 no
 4:1

Seal SWIVEL:

excellent
 excellent
 no
 4:1

Notes: 1) To obtain the ISO 6149 type of sealing please take out the retaining ring from the standard fitting.
 2) The values in the tightening tables are approximate, which may vary based on the materials and tolerances of the components used.

STUD ENDS WITH UNF/UN-2A THREAD

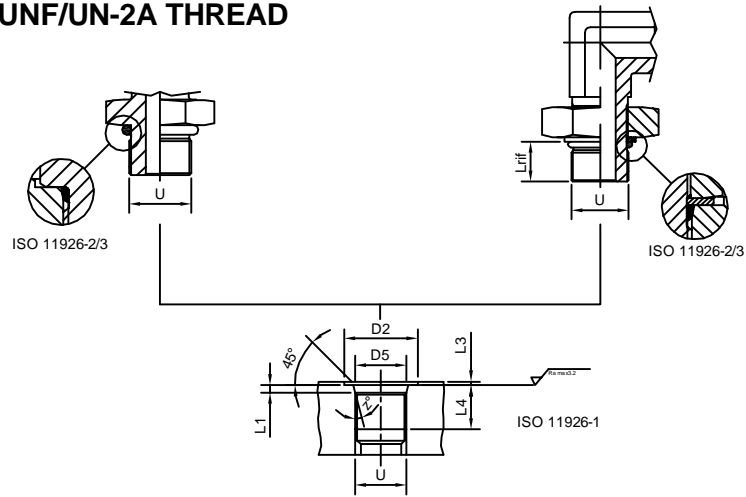

Series	ØTube	UNF/UN thread	D2 min	D5	L1	L3 max	L4 min	L rif	Z°	STRAIGHT	SWIVEL
L	6	7/16-20 UNF-2A	21	12.45	2.4	1.6	11.5	9.9	12	20	20
	8-10	1/2-20 UNF-2A	23	14.05	2.4	1.6	11.5	9.9	12	25	25
	12	9/16-18 UNF-2A	25	15.7	2.5	1.6	12.7	11.1	12	30	30
	15-18	3/4-16 UNF-2A	30	20.65	2.5	2.4	14.3	12.5	15	45	45
	18	7/8-14 UNF-2A	34	24	2.5	2.4	16.7	14.5	15	55	55
	22	1 1/16-12 UN-2A	41	29.2	3.3	2.4	19	16.8	15	85	85
	28	1 5/16-12 UN-2A	49	35.55	3.3	3.2	19	16.8	15	130	130
	35	1 5/8-12 UN-2A	58	43.55	3.3	3.2	19	16.8	15	170	170
S	42	1 7/8-12 UN-2A	65	49.9	3.3	3.2	19	16.8	15	180	180
	6-8	1/2-20 UNF-2A	23	14.05	2.4	1.6	11.5	9.9	12	25	25
	10-12	9/16-18 UNF-2A	25	15.7	2.5	1.6	12.7	11.1	12	35	35
	14-16	3/4-16 UNF-2A	30	20.65	2.5	2.4	14.3	12.5	15	60	60
	16	7/8-14 UNF-2A	34	24.29	2.5	2.4	16.7	14.5	15	85	85
	20	1 1/16-12 UN-2A	41	2	3.3	2.4	19	16.8	15	150	150
	25	1 5/16-12 UN-2A	49	35.55	3.3	3.2	19	16.8	15	230	230
JIC 37°	30	1 5/8-12 UN-2A	58	43.55	3.3	3.2	19	16.8	15	250	250
	38	1 7/8-12 UN-2A	65	49.9	3.3	3.2	19	16.8	15	320	320
	6	7/16-20 UNF-2A	21	12.45	2.4	1.6	11.5	9.9	12	20	20
	8	1/2-20 UNF-2A	23	14.05	2.4	1.6	11.5	9.9	12	25	25
	10	9/16-18 UNF-2A	25	15.7	2.5	1.6	12.7	11.1	12	30	30
	12	3/4-16 UNF-2A	30	20.65	2.5	2.4	14.3	12.5	15	45	45
	14-15-16	7/8-14 UNF-2A	34	24	2.5	2.4	16.7	14.5	15	55	55
	18-20	1 1/16-12 UN-2A	41	29.2	3.3	2.4	19	16.8	15	85	85
	25	1 5/16-12 UN-2A	49	35.55	3.3	3.2	19	16.8	15	130	130
	30-32	1 5/8-12 UN-2A	58	43.55	3.3	3.2	19	16.8	15	170	170
ORFS	38	1 7/8-12 UN-2A	65	49.9	3.3	3.2	19	16.8	15	180	180
	6	7/16-20 UNF-2A	21	12.45	2.4	1.6	11.5	11.4	12	20	20
	8-10	9/16-18 UNF-2A	25	15.7	2.5	1.6	12.7	12.2	12	35	55
	12	3/4-16 UNF-2A	30	20.65	2.5	2.4	14.3	13.8	15	60	60
	14-15-16	7/8-14 UNF-2A	34	24	2.5	2.4	16.7	16.3	15	85	85
	18-20	1 1/16-12 UN-2A	41	29.2	3.3	2.4	19	18.6	15	150	150
	22-25	1 5/16-12 UN-2A	49	35.55	3.3	3.2	19	18.6	15	230	230
	28-30-32	1 5/8-12 UN-2A	58	43.55	3.3	3.2	19	18.6	15	250	250
	35-38	1 7/8-12 UN-2A	65	49.9	3.3	3.2	19	18.6	15	320	320

Performance:

-pressure capacity
 -sealing characteristics
 -additional sealing required
 -safety factor

Seal STRAIGHT:

excellent
 excellent
 no
 4:1

Seal SWIVEL:

excellent
 excellent
 no
 4:1

Notes: The values in the tightening tables are approximate, which may vary based on the materials and tolerances of the components used.

STUD ENDS WITH BSPT THREAD

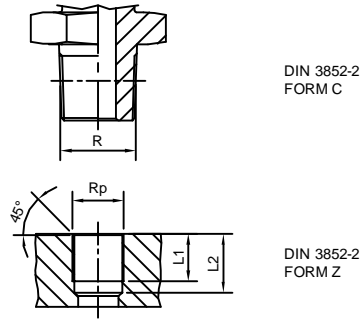

DIN 3852-2
FORM C

DIN 3852-2
FORM Z

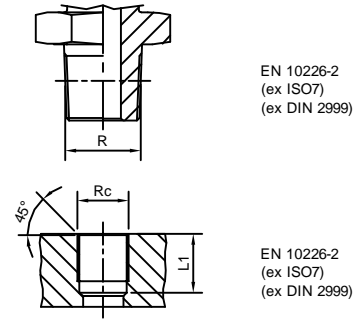

EN 10226-2
(ex ISO7)
(ex DIN 2999)

EN 10226-2
(ex ISO7)
(ex DIN 2999)

Series	ØTube	BSPT thread (DIN 3852-2 form C)	L1	L2
L	6	R 1/8	5.5	8.5
	8-10	R 1/4	8.5	12.5
	12	R 3/8	8.5	12.5
	15-18	R 1/2	10.5	16.5
	18	R 3/4	13	19
	22	R 1	-	-
	28	R 1 1/4	-	-
	35	R 1 1/2	-	-
S	42	R 1/4	8.5	12.5
	6-8	R 3/8	8.5	12.5
	10-12	R 1/2	10.5	16.5
	14-16	R 3/4	13	19
	16	R 1	-	-
	20	R 1 1/4	-	-
	25	R 1 1/2	-	-

Series	ØTube	BSPT thread (EN 10226-2)	L1
L	6	R 1/8	7.4
	8	R 1/4	11
	10	R 3/8	11.4
	12-14-15-16	R 1/2	15
	18-20	R 3/4	16.3
	25	R 1	19.1
	30-32	R 1 1/4	21.4
	38	R 1 1/2	21.4
S	-	R 1/8	7.4
	-	R 1/4	11
	-	R 3/8	11.4
	-	R 1/2	15
	-	R 3/4	16.3
	-	R 1	19.1
	-	R 1 1/4	21.4
	-	R 1 1/2	21.4
-	R 2	25.7	

Performance:
 -pressure capacity
 -sealing characteristics
 -additional sealing required
 -safety factor

Taper Sealing C:
 low-medium
 low-medium
 Yes
 2,5:1

Performance:
 -pressure capacity
 -sealing characteristics
 -additional sealing required
 -safety factor

Taper Sealing C:
 low-medium
 low-medium
 Yes
 2,5:1

Series	ØTube	Thread Metric Taper	L1	L2
L	6	M10x1 keg	5.5	10
	8	M12x1.5 keg	8.5	13.5
	10	M14x1.5 keg	8.5	13.5
	12	M16x1.5 keg	8.5	13.5
	15	M18x1.5 keg	8.5	13.5
	18	M22x1.5 keg	10.5	15.5
S	6	M12x1.5 keg	8.5	13.5
	8	M14x1.5 keg	8.5	13.5
	10	M16x1.5 keg	8.5	13.5
	12	M18x1.5 keg	8.5	13.5
	14	M20x1.5 keg	10.5	15.5
	16	M22x1.5 keg	10.5	15.5

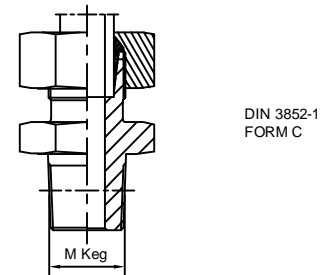

DIN 3852-1
FORM C

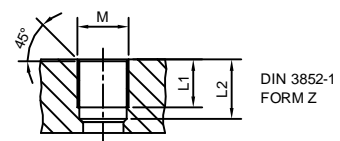

DIN 3852-1
FORM Z

Performance:
 -pressure capacity
 -sealing characteristics
 -additional sealing required
 -safety factor

Taper Sealing C:
 low-medium
 low-medium
 Yes
 2,5:1

STUD ENDS WITH NPT/NPTF THREAD

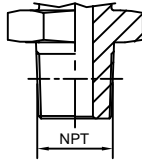

ANSI/ASME B1.20.1

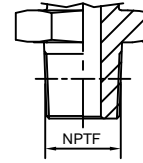

ANSI/ASME B1.20.3

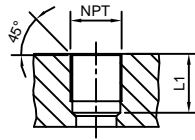

ANSI/ASME B1.20.1

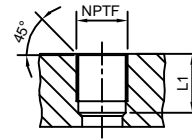

ANSI/ASME B1.20.3

Series	ØTube	NPT Thread	L1
L	6	1/8-27 NPT	11.6
	8-10	1/4-18 NPT	16.4
	12	3/8-18 NPT	17.4
	15-18	1/2-14 NPT	22.6
	22	3/4-14 NPT	23.1
	28	1-11,5 NPT	27.8
	35	1 1/4-11,5 NPT	28.3
S	42	1 1/2-11,5 NPT	28.3
	6-8	1/4-18 NPT	16.4
	10-12	3/8-18 NPT	17.4
	14-16	1/2-14 NPT	22.6
	20	3/4-14 NPT	23.1
	25	1-11,5 NPT	27.8
Bs 5200	30	1 1/4-11,5 NPT	28.3
	38	1 1/2-11,5 NPT	28.3
	-	1/8-27 NPT	11.6
	-	1/4-18 NPT	16.4
	-	3/8-18 NPT	17.4
	-	1/2-14 NPT	22.6
	-	3/4-14 NPT	23.1
	-	1-11,5 NPT	27.8
-	1 1/4-11,5 NPT	28.3	
-	1 1/2-11,5 NPT	28.3	
-	2-11,5 NPT	29	

Series	ØTube	NPTF thread	L1
JIC 37° - ORFS	6-8	1/8-27 NPTF	11.6
	8-10	1/4-18 NPTF	16.4
	12	3/8-18 NPTF	17.4
	14-15-16	1/2-14 NPTF	22.6
	18-20	3/4-14 NPTF	23.1
	22-25	1-11,5 NPTF	27.8
	28-30-32	1 1/4-11,5 NPTF	28.3
	35-38	1 1/2-11,5 NPTF	28.3

Performance:
 -pressure capacity
 -sealing characteristics
 -additional sealing required
 -safety factor

Taper Sealing C:
 low-medium
 low-medium
 Yes
 2,5:1

Performance:
 -pressure capacity
 -sealing characteristics
 -additional sealing required
 -safety factor

Taper Sealing C:
 low-medium
 low-medium
 Yes
 2,5:1

● PRESCRIPTIONS TO COMPLY WITH FOR ALL THE SERIES

- Only use HYFIT products and components for the same assembly to prevent claims and damage to people and objects.
- Apply completely the general instructions, utilisation standards, safety factors, assembly instructions and working pressures for the specific fitting used.
- Closely respect the working temperature ranges, the relevant pressure changes reported and stay within the set values in bars.
- Respect the indicated tightening values as well as the assembly instructions.
- Lubricate all the components, as indicated in the assembly instructions, with specific products.
- All carbon steel connections must be pre-assembled before being mounted onboard the machine. It is not allowed to assemble them directly on the machine.
- All stainless steel connections must be pre-assembled or flared with hardened tools before being mounted onboard the machine. It is not allowed to assemble them directly on the machine.
- Only use the carbon steel and stainless steel tubes mentioned on pages.
- Use support sleeves on thin tubes.
- It is not advisable to mix carbon and stainless steel components together in the same connection.
- Always check the correct alignment of the system, tubes, connections and actuators.
- It is mandatory to always check the correct incision of the cutting ring on the tube!
- The use of non-compliant tubes, fittings or connection is not allowed.
- It is not allowed to alter HYFIT products in any way.
- Fully comply with all the indications contained in this Technical Commercial Catalogue.

Failure of follow any of these prescriptions may alter the functionality of the products and void any guarantee.

It is not allowed to mix and use components from production of different manufacturers oleo-dynamic fittings. The product traceability coding applies.

Users are not allowed to made changes to or repair the oleo-dynamic fittings we manufacture; in such case lawbreakers will be liable for their actions and any damage caused to the environment, people and objects.

Fluids under pressure may cause serious damage to people and objects; it is thus necessary to always pay the utmost attention, fully respecting the applicable prescriptions and adopting the principle of prudence to avoid any accident to oneself and the others.

ASSEMBLY INSTRUCTIONS ACCORDING TO DIN 3859 - 2 FOR F-F4.

1. Before pre-assembly, make sure that all the tools be used are in perfect working order.
Replace any non-complying tool.
2. The segment of the tube to be pre-assembled must have a straight section at least twice the length of the nut (length H). Roundness must comply with DIN 2391.
3. Cut the tube square by using an appropriate hack-saw (do not use roller type tube cutters). Check that the cut is properly made at 90°. Remove any internal and external burrs.
4. Oil the 24° cone, the thread of the body, the cutting ring and the nut with suitable products. =
5. Fit the nut and the cutting ring on the tube shown. The larger diameter of the cutting ring must face the nut.
6. Insert the tube on the 24° cone until it comes into contact with the stop. Tighten the nut by hand until the cutting ring rests firmly on the nut. Then tighten the nut with a wrench until the cutting edge of the ring is in contact with the tube and prevents rotation of this.
7. Holding the tube against its stop and making sure it does not rotate, tighten the nut by 3/4 of turn. This way, the cutting edge of the ring cuts into the outer part of the tube for the necessary depth and raises an edge in front of its cutting edge while the second cutting edge clinches the tube at the same time.
8. Loosen the nut and check that there is a clearly raised edge all round the tube. the edge must cover 80% of the front of the cutting ring according to DIN 3859 part II. This check is peremptory for the safety of all concerned!!! If the raised edge is not satisfactory, pre-assembly must be repeated.
9. If pre-assembly has been carried out correctly, fit the tube on the machine, close with a wrench until a certain resistance is encountered and then tighten for a further 1/4 turn with wrench to wrench contrast.
10. All the pre-assembly of stainless steel fittings must be performed with hardened tools (blocks or machines).

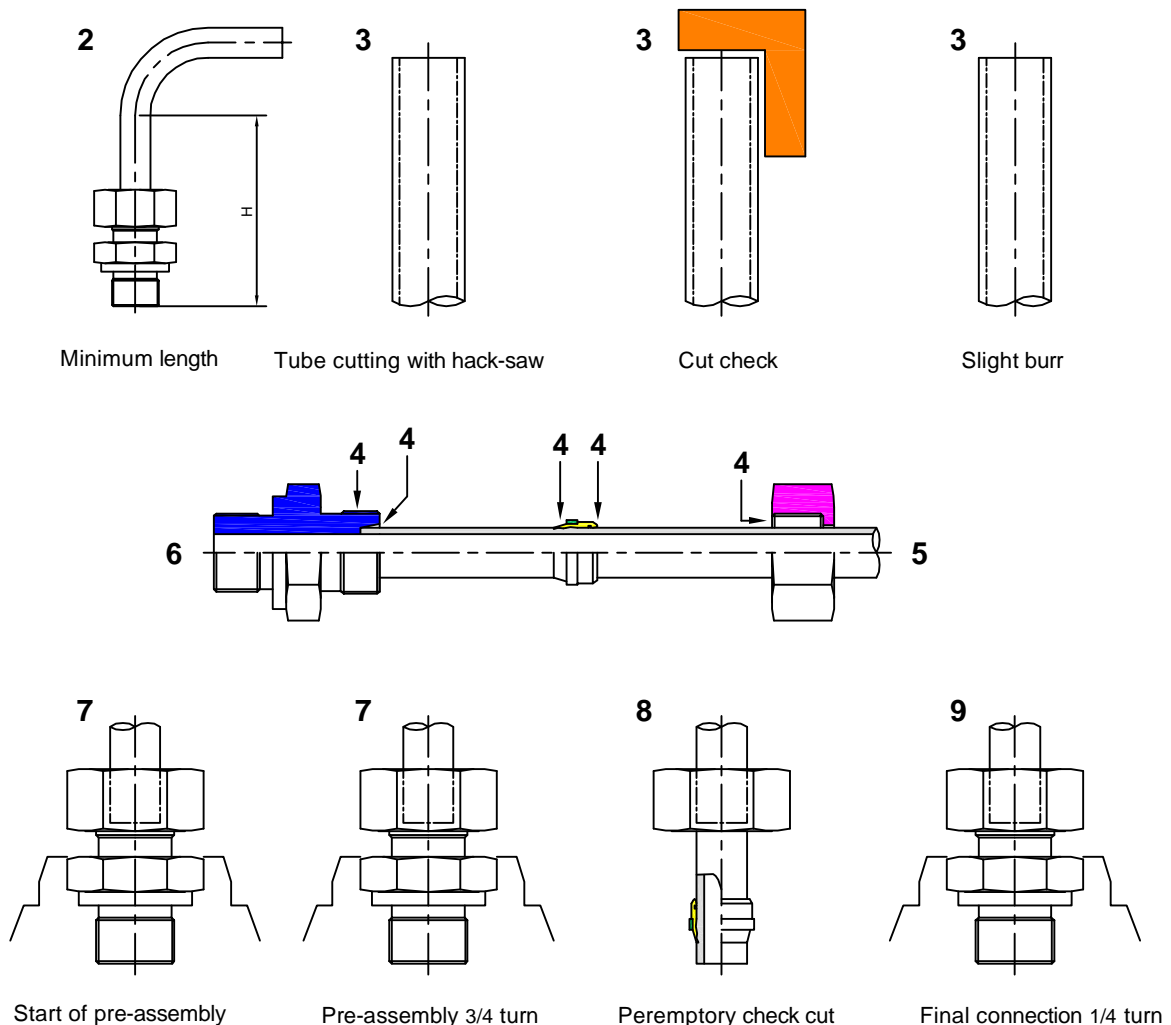

PRESCRIPTIONS FOR THE INSTALLATION OF RIGID TUBES

To ensure the correct cabling of an oleo-dynamic system made of (steel) rigid tubes for high pressures it is necessary to respect the provisions of the standards and of the manufacturer of the fittings. Only use high quality tubes and related fittings, scrupulously complying with the maximum working pressures and temperature allowed. Correctly assemble the selected tubes, using collars that fit the size of the tubes. Do not fasten the tube to electric conduits or other tubes.

When arranging the system, take into account the space needed for maintenance interventions. The tubes support must be created according to the tables below. It is important to obtain the correct alignment between tubes, fittings and actuators. An aesthetically well structured system is synonym with functionality and safety.

Some examples of correct installation:

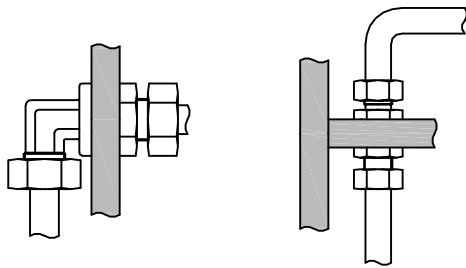

Properly fasten the fittings that host the tubes

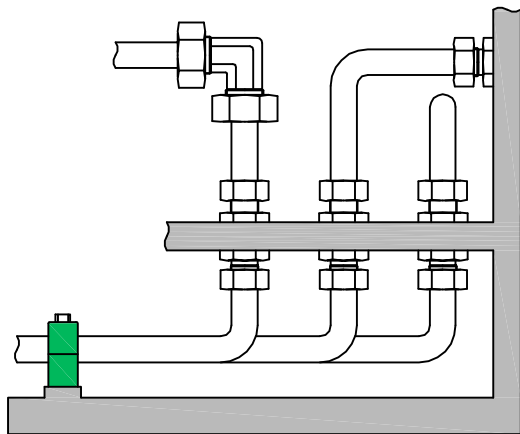

Do not overlay the tubes to facilitate maintenance

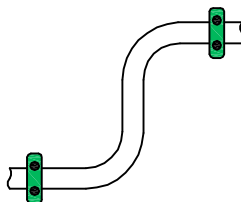

Follow the table indicated as closely as possible.

Ø Tube (mm)	L (mt)
6-12	0.5
12-22	0.6
22-32	0.7
32-38	1.0
38-42	1.3

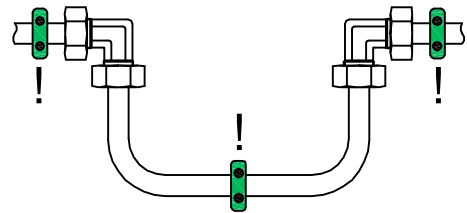

Do not excessively fasten the tubes as these must always be allowed to dilate without any problem

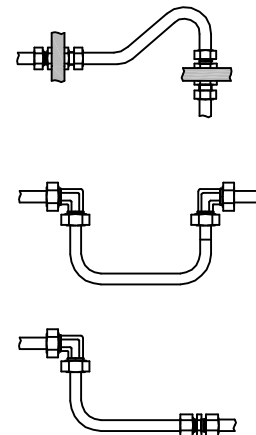

Do not subject the fittings to stress deriving from a poor alignment of the tube which must be able to expand

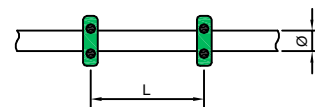

Follow the table indicated as closely as possible.

Ø Tube (mm)	L (mt)
6-12	1.0
12-22	1.2
22-32	1.5
32-38	2.0
38-42	2.7

NON RETURN VALVE

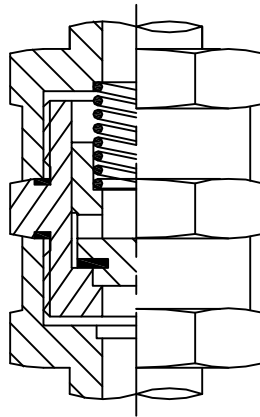

THEORY OF OPERATION

HYFIT ENGINEERS. non return valve is used in all those circuits where the fluid must flow in one way only, avoiding the flow in the opposite direction

TO OBTAIN PERFECT SEALING:

1. Make sure that all tubes are perfectly clean and that there are no impurities in the system where the fluid will flow.
2. Remove protective caps only when ready to assemble, making sure that in the assembly phase no impurities enter the system.

TECHNICAL CHARACTERISTICS

1. HYFIT ENGINEERS non return valve assures a perfect tightness of the circuit, provided that the indicated nominal working pressures are kept as referred to in this catalogue.
2. The particular profile of its inner elements assures the correct flow with a minimum pressure drop.
3. The valve is a compact, particularly sturdy element; the seal is obtained by a plain seat metal to metal plug with an elastomeric seal gasket assuring tightness at low working pressures.
4. A basic body allows to different types of non return valves to be interchanged by applying, from time to time, the different engaged stud ends as chosen by the customer, allowing for easy logistic of the stock.
5. The valve may be used for conveying mineral oils, fuels, compressed air or gases. When ordering please specify if the fluid needs specific type of gaskets.
6. The nominal working temperature is between -40°C and $+120^{\circ}\text{C}$ for carbon steel, and between -60°C and $+200^{\circ}\text{C}$ for stainless steel. The limit may change according to the type of gasket used.

TECHNICAL DATA

Maximum advised flow speed is 5mt/sec. The standard opening pressure is 1 bar; if specified when ordering, we can supply non return valves with an opening pressure up to 3 bars with 0.5 bar steps.

COMPONENT TESTING

All the valves are checked for leaks at low pressure and at the opening value; high pressure tests are carried out at the maximum nominal working pressure plus 33%.

TIGHTENING TORQUES FOR F, F4 CUTTING RINGS

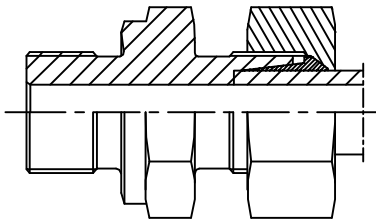

Assembly of H3 ring on fitting body

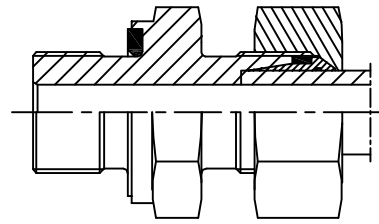

Assembly of H4 ring on fitting body

Series	ØTube	Metric thread	Manual carbon (Nm)	Manual stainless (Nm)	Machine carbon (Kg)	Machine stainless (Kg)
L	6	M12x1.5	20	30	1200	1400
	8	M14x1.5	25	55	1400	1700
	10	M16x1.5	30	85	2000	2200
	12	M18x1.5	40	120	2100	2400
	15	M22x1.5	60	130	2400	3300
	18	M26x1.5	90	220	2500	3600
	22	M30x2	170	320	2600	3800
	28	M36x2	210	500	3000	6900
	35	M45x2	360	970	5500	10000
S	42	M52x2	490	1110	6700	12500
	6	M14x1.5	25	45	1200	1400
	8	M16x1.5	30	55	14000	1700
	10	M18x1.5	40	90	2000	2200
	12	M20x1.5	50	105	2100	2400
	14	M22x1.5	70	150	2400	3300
	16	M24x1.5	80	180	2500	3600
	20	M30x2	140	340	2600	6400
	25	M36x2	230	530	5000	9300
	30	M42x2	300	610	5500	10000
38	M52x2	430	850	6700	12500	

Notes: The values in the tightening tables are approximate, which may vary based on the materials and tolerances of the components used.

All the values expressed in Newton Meters (Nm) for the tightening torques on the cone DIN 3861 represent the torquing moment needed to have the correct incision of the pre-assembly of the tube, lifting the required 80% of the edge of the cutting ring.

All the values expressed in Kilograms (Kg) for the linear push on the pre-assembly machine, represent the right strength necessary to have the correct incision of the pre-assembly lifting the required 80% of the front if the cutting ring.

Once the pre-assembly has been carried out correctly and after checking that all the components conform to the system requirements, complete the assembly on the system itself, first closing by wrench until you feel a certain resistance, and then doing the last 1/4 of a turn to close the fitting completely.

SWIVEL NUT DIN 2353

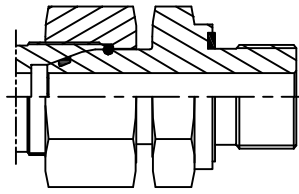

According to DIN 2353 standards, 24° cone as per DIN 3861 and o-ring seal as per DIN 3865.

This series of fittings with revolving nut and seal on the 24° cone guaranteed by an o-ring meets the requirements of customers asking for high pressure, absolute tightness and low tightening torque.

Due to its technical characteristics this type of fitting is suitable for demanding applications, such as assembly on heavy machinery. the result is a safe fastening of the nut to the body improving the whole sealing system.

The limit of this series lies in that the sealing performed with the o-ring is limited to a single connection, leaving all the others uncovered by this excellent solution.

A new step forward was needed to improve the research and find a solution that could grant a double sealing system on all the connections involved, metal to metal plus the elastomeric sealing.

This problem has been solved by HYFIT ENGINEERS with new "F4" cutting ring, guaranteeing a double sealing (metal and gasket) on all the connections of the fitting.

ASSEMBLY INSTRUCTIONS FOR SWIVEL CONE SERIES DIN 2353

1. Before the assembly, check for the correct parameters of all the tools to be used and substitute those not complying to the requirements.
2. Clean the nut, fitting and tube and lubricate with the suggested products.
3. Check the correct alignment of the parts involved, then using a wrench tighten until reaching the metal to metal contact of the conical parts.
4. Repeated assembly and disassembly will not alter the functionality of the system which, each time is closed, will always provided an immediate seal, which will last over time.
5. Please refer to the related tables for the correct tightening torques to be applied.

TIGHTENING TORQUES ON THE SWIVEL CONE DIN 3861 cone for carbon and stainless steel

Series	ØTube	Metric thread	Torque (Nm)
L	6	M12x1.5	20
	8	M14x1.5	35
	10	M16x1.5	40
	12	M18x1.5	45
	15	M22x1.5	55
	18	M26x1.5	110
	22	M30x2	130
	28	M36x2	200
	35	M45x2	220
S	42	M52x2	240
	6	M14x1.5	40
	8	M16x1.5	45
	10	M18x1.5	50
	12	M20x1.5	60
	14	M22x1.5	80
	16	M24x1.5	100
	20	M30x2	160
	25	M36x2	240
	30	M42x2	260
38	M52x2	350	

Notes:

The values in the tightening tables are approximate, which may vary based on the materials and tolerances of the components used.

All the values expressed in Newton Meters (Nm) for the tightening torques on the swivel cone represent the torquing moment needed to have the correct tightness.

ASSEMBLY INSTRUCTIONS FOR ADJUSTABLE FITTINGS

**ISO 6149 Metric thread
ISO 11926 UNF/UN-2A thred**

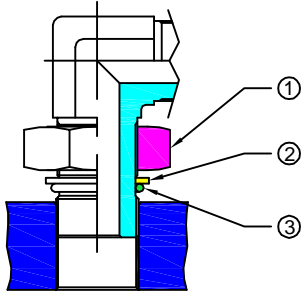

- 1 Back up hexagonal nut
- 2 Back up sleeve
- 3 O-ring
- 4 Retaining ring

**BSPP Thread (in revision phase)
ISO 6149 Metric thread
with retaining ring**

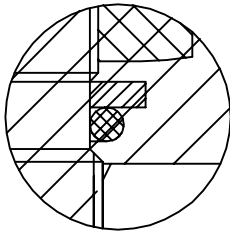
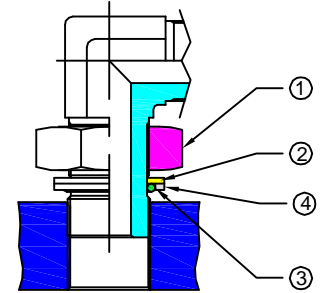

Lubricate the o-ring.
Unscrew the back up hexagonal nut and check that the back up sleeve is positioned as in the picture.
The correct position of the back up sleeve may be obtained when the fitting is screwed into the female thread.

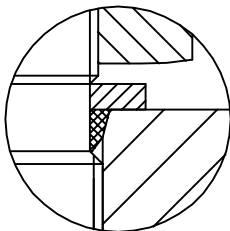
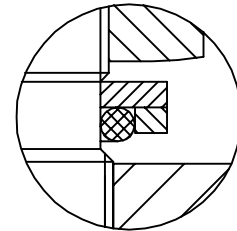

Screw the fitting up to the point where the back up sleeve or the retaining ring is in contact with the machined surface, checking that the o-ring is positioned correctly into its shaped housing.

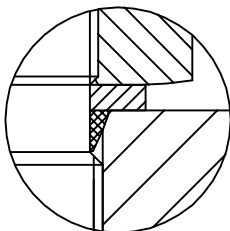
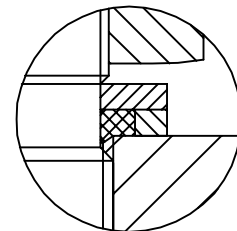

Unscrew the fitting up to a maximum of 1 turn to obtain the desired positioning. Keep the fitting still with a wrench and block the back up hexagonal nut. Please refer to the related tables for the correct tightening torques to be applied.

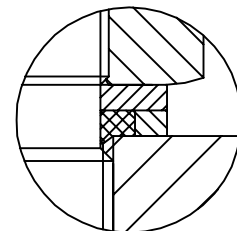

N.B. To obtain the ISO 6149 type of seal please take out the retaining ring from the standard fitting.

STAINLESS STEEL SINGLE EDGE CUTTING RING

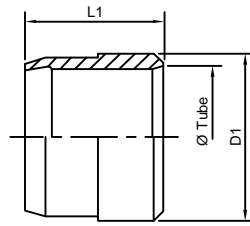

Series	WP (bar)	HP ring ordering	Ø Tube	L1	D1
L	250	HP-6L	6	9	9
		HP-8L	8	9	11
		HP-10L	10	9.5	13
		HP-12L	12	9.5	15
		HP-15L	15	9.5	18
	160	HP-18L	18	9.5	22
		HP-22L	22	10.5	26
		HP-28L	28	11	32
	100	HP-35L	35	13	41
		HP-42L	42	13	48
S	630	HP-6S	6	9	9
		HP-8S	8	9	11
		HP-10S	10	9.5	13
		HP-12S	12	9.5	15
		HP-14S	14	10	19
	400	HP-16S	16	10.5	21
		HP-20S	20	12	26
		HP-25S	25	12	32
	250	HP-30S	30	13	36
		HP-38S	38	13	44

CUTTING RING

This new ring (working pressure as per DIN 2353/ISO 8434-1), due to its particular geometric configuration with acute corner cutting, allows the cabling onboard the machine in complete absence of losses, leakages or sweating. It may be assembled on all the fittings with opening DIN 3861

FINISHED ELEMENTS METHOD

The design in the field of mechanical engineering and construction is becoming more and more sophisticated, requiring for the related calculation to be made by using more advanced tools.

The "Finished elements method" is one of the numeric techniques used to solve the problems of calculation, quickly providing an idea of the strain and deformation distribution of the element.

The main concept underlying this methodology is to subdivide the model subject to analysis into triangles and therefore approximate the solution by using polynomial interpolation.



SECTIONAL REPRESENTATION OF THE CAST "HP" RING

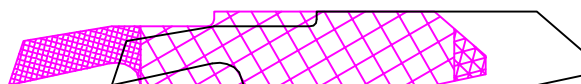

REPRESENTATION OF DEFORMED RETICULATION

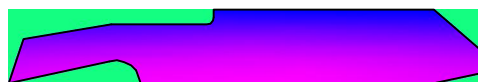

REPRESENTATION OF NON-MISES STRESSE

CUTTING RING (FERRULE)

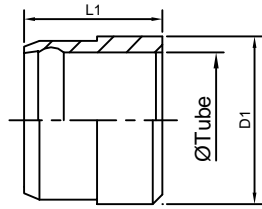

"F"

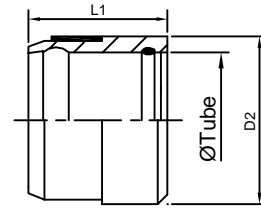

"F4"

Series	WP (bar)	Part no. F3	Ø Tube	L1	D1	D2	Part no. F4
LL	100	HF-F-4LL	4	6	6	-	-
		HF-F-6LL	6	7	8	-	-
		HF-F-8LL	8	7	10	-	-
L	315	HF-F-6L	6	9.5	10	10	HF-F4-6L
		HF-F-8L	8	9.5	12	12	HF-F4-8L
		HF-F-10L	10	10	14	14	HF-F4-10L
		HF-F-12L	12	10	16	16	HF-F4-12L
		HF-F-15L	15	10	19	20	HF-F4-15L
		HF-F-18L	18	10	23	23	HF-F4-18L
	160	HF-F-22L	22	10.5	27	27	HF-F4-22L
		HF-F-28L	28	11	33	33	HF-F4-28L
		HF-F-35L	35	13	41	41	HF-F4-35L
		HF-F-42L	42	13	48	48	HF-F4-42L
		HF-F-6S	6	9.5	10	10	HF-F4-6S
		HF-F-8S	8	9.5	12	12	HF-F4-8S
S	630	HF-F-10S	10	10	14	14	HF-F4-10S
		HF-F-12S	12	10	16	16	HF-F4-12S
		HF-F-14S	14	10	19	19	HF-F4-14S
		HF-F-16S	16	10.5	21	21	HF-F4-16S
		HF-F-20S	20	12	26	26	HF-F4-20S
		HF-F-25S	25	12	32	32	HF-F4-25S
	400	HF-F-30S	30	13	36	38	HF-F4-30S
		HF-F-38S	38	13	44	48	HF-F4-38S

CUTTING RING "F4"

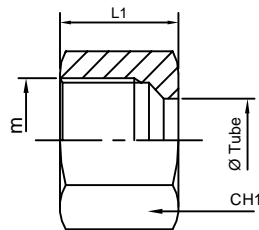

Series	WP (bar)	Part no.	Ø Tube	m	L1	CH1
LL	100	HF-CN-4LL	4	8X1	11	10
		HF-CN-6LL	6	10X1	11.5	12
		HF-CN-8LL	8	12X1	12	14
L	315	HF-CN-6L	6	12X1.5	14.5	14
		HF-CN-8L	8	14X1.5	14.5	17
		HF-CN-10L	10	16X1.5	15.5	19
		HF-CN-12L	12	18X1.5	15	22
		HF-CN-15L	15	22X1.5	17	27
		HF-CN-18L	18	26X1.5	18	32
	160	HF-CN-22L	22	30X2	20	36
		HF-CN-28L	28	36X2	21	41
		HF-CN-35L	35	45X2	24	50
		HF-CN-42L	42	52X2	24	60
		HF-CN-6S	6	14X1.5	16	17
		HF-CN-8S	8	16X1.5	16	19
S	630	HF-CN-10S	10	18X1.5	17	22
		HF-CN-12S	12	20X1.5	17	24
		HF-CN-14S	14	22X1.5	20.5	27
		HF-CN-16S	16	24X1.5	20.5	30
		HF-CN-20S	20	30X2	24	36
		HF-CN-25S	25	36X2	27	46
	400	HF-CN-30S	30	42X2	29	50
		HF-CN-38S	38	52X2	32	60

MALE STUD COUPLING

Thread BSP Parallel

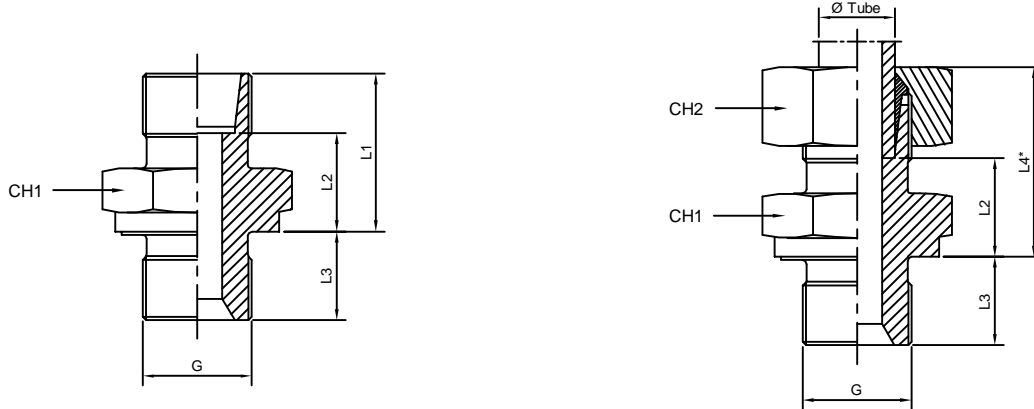

Series	W.P (Bar)	Part No.	Ø Tube	G	L1	L2	L3	L4*	CH1	CH2
L	315	HF-MSB-6L-1/8	6	1/8	15.5	8.5	8	23	14	14
		HF-MSB-8L-1/4	8	1/4	17	10	12	25	19	17
		HF-MSB-10L-1/4	10	1/4	18	11	12	26	19	19
		HF-MSB-12L-3/8	12	3/8	19.5	12.5	12	27	22	22
	160	HF-MSB-15L-1/2	15	1/2	21	14	14	29	27	27
		HF-MSB-18L-1/2	18	1/2	22	14.5	14	31	27	32
		HF-MSB-22L-3/4	22	3/4	24	16.5	16	33	32	36
		HF-MSB-28L-1	28	1	25	17.5	18	34	41	41
S	630	HF-MSB-6S-1/4	6	1/4	20	13	12	28	19	17
		HF-MSB-8S-1/4	8	1/4	22	15	12	30	19	19
		HF-MSB-10S-3/8	10	3/8	22.5	15	12	31	22	22
		HF-MSB-12S-3/8	12	3/8	24.5	17	12	33	22	24
	400	HF-MSB-14S-1/2	14	1/2	27	19	14	37	27	27
		HF-MSB-16S-1/2	16	1/2	27	18.5	14	37	27	30
		HF-MSB-20S-3/4	20	3/4	31	20.5	16	42	32	36
		HF-MSB-25S-1	25	1	35	23	18	47	41	46
		HF-MSB-30S-1 1/4	30	1 1/4	37	23.5	20	50	50	50
		HF-MSB-38S-1 1/2	38	1 1/2	42	26	22	57	55	60
L	315	HF-MSB-6L-1/4	6	1/4	17	10	12	24.5	19	14
		HF-MSB-8L-1/8	8	1/8	16.5	9.5	8	24.5	14	17
		HF-MSB-8L-3/8	8	3/8	18.5	11.5	12	26.5	22	17
		HF-MSB-8L-1/2	8	1/2	19	12	14	27	27	17
		HF-MSB-10L-1/8	10	1/8	17.5	10.5	8	25.5	17	19
		HF-MSB-10L-3/8	10	3/8	19.5	12.5	12	27.5	22	19
		HF-MSB-10L-1/2	10	1/2	20	13	14	28	27	19
		HF-MSB-12L-1/4	12	1/4	19	12	12	26.5	19	22
	HF-MSB-12L-1/2	12	1/2	20	13	14	27.5	27	22	
	HF-MSB-15L-3/8	15	3/8	20.5	13.5	12	28.5	24	27	
HF-MSB-18L-3/4	18	3/4	22	14.5	16	31	32	32		
S	630	HF-MSB-12S-1/2	12	1/2	25	17.5	14	33.5	27	24
		HF-MSB-14S-3/8	14	3/8	26.5	18.5	12	36.5	24	27
	400	HF-MSB-16S-3/8	16	3/8	26.5	18	12	36.5	27	30
		HF-MSB-20S-1/2	20	1/2	31	20.5	14	42	32	36
		HF-MSB-25S-3/4	25	3/4	35	23	16	47	41	46
		HF-MSB-30S-1	30	1	37	23.5	18	50	46	50
	630	HF-MSB-8S-3/8	8	3/8	22.5	15.5	12	30.5	22	19
		HF-MSB-10S-1/4	10	1/4	22	14.5	12	30.5	19	22
		HF-MSB-10S-1/2	10	1/2	25	17.5	14	33.5	27	22
		HF-MSB-12S-1/4	12	1/4	24	16.5	12	32.5	22	24
	400	HF-MSB-16S-3/4	16	3/4	29	20.5	16	39	32	30
		HF-MSB-20S-1	20	1	33	22.5	18	44	41	36
315	HF-MSB-38S-1 1/4	38	1 1/4	42	26	20	57	55	60	
L	160	HF-MSB-16L-3/4	15	3/4	22	15	16	30	32	27
		HF-MSB-22L-1/2	22	1/2	24	16.5	14	33	32	36
		HF-MSB-22L-1	22	1	25	17.5	18	34	41	36
		HF-MSB-28L-3/4	28	3/4	25	17.5	16	34	41	41
	HF-MSB-35L-1	35	1	28	17.5	18	39	46	50	
	315	HF-MSB-6L-3/8	6	3/8	18.5	11.5	12	26	22	14
	160	HF-MSB-42L-1 1/4	42	1 1/4	30	19	20	42	55	60

MALE STUD COUPLING

Thread Metric Parallel

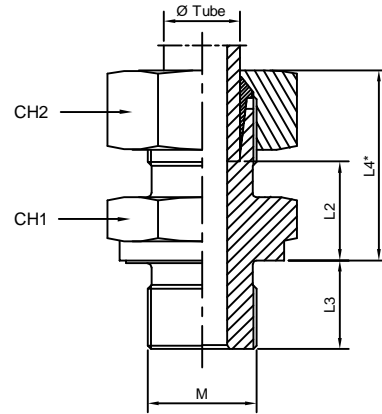
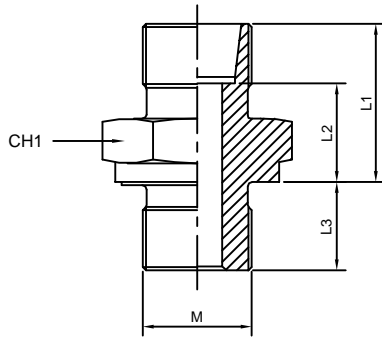

Series	W.P (Bar)	Part No.	Ø Tube	M	L1	L2	L3	L4*	CH1	CH2	
L	315	HF-MSM-6L-M10X1	6	10X1	15.5	8.5	8	23	14	14	
		HF-MSM-8L-M12X1.5	8	12X1.5	17	10	12	25	17	17	
		HF-MSM-10L-M14X1.5	10	14X1.5	18	11	12	26	19	19	
		HF-MSM-12L-M16X1.5	12	16X1.5	19.5	12.5	12	27	22	22	
		HF-MSM-15L-M18X1.5	15	18X1.5	20.5	13.5	12	29	24	27	
		HF-MSM-18L-M22X1.5	18	22X1.5	22	14.5	14	31	27	32	
	160	HF-MSM-22L-M26X1.5	22	26X1.5	24	16.5	16	33	32	36	
		HF-MSM-28L-M33X2	28	33X2	25	17.5	18	34	41	41	
		HF-MSM-35L-M42X2	35	42X2	28	17.5	20	39	50	50	
		HF-MSM-42L-M48X2	42	48X2	30	19	22	42	55	60	
S	630	HF-MSM-6S-M12X1.5	6	12X1.5	20	13	12	28	17	17	
		HF-MSM-8S-M12X1.5	8	14X1.5	22	15	12	30	19	19	
		HF-MSM-10S-M16X1.5	10	16X1.5	22.5	15	12	31	22	22	
		HF-MSM-12S-M18X1.5	12	18X1.5	24.5	17	12	33	24	24	
		HF-MSM-14S-M20X1.5	14	20X1.5	27	19	14	37	27	27	
	400	HF-MSM-16S-M22X1.5	16	22X1.5	27	18.5	14	37	27	30	
		HF-MSM-20S-M27X2	20	27X2	31	20.5	16	42	32	36	
		HF-MSM-25S-M33X2	25	33X2	35	23	18	47	41	46	
		HF-MSM-30S-M42X2	30	42X2	37	23.5	20	50	50	50	
	315	HF-MSM-38S-M48X2	38	48X2	42	26	22	57	55	60	
	L	315	HF-MSM-8L-M18X1.5	8	18X1.5	18.5	11.5	12	26.5	24	17
			HF-MSM-10L-M16X1.5	10	16X1.5	19.5	12.5	12	27.5	22	19
			HF-MSM-10L-M18X1.5	10	18X1.5	19.5	12.5	12	27.5	24	19
HF-MSM-10L-M22X1.5			10	22X1.5	21	14	14	29	27	19	
HF-MSM-12L-M14X1.5			12	14X1.5	19.5	12.5	12	27	19	22	
HF-MSM-12L-M18X1.5			12	18X1.5	19.5	12.5	12	27	24	22	
HF-MSM-12L-M12X1.5			12	22X1.5	21	14	14	28.5	27	22	
HF-MSM-15L-M16X1.5			15	16X1.5	20	13	12	28	24	27	
HF-MSM-15L-M22X1.5			15	22X1.5	22	15	14	30	27	27	
HF-MSM-18L-18X1.5			18	18X1.5	21.5	14	12	30.5	27	32	
160		HF-MSM-22L-22X1.5	22	22X1.5	24	16.5	14	33	32	36	
S		400	HF-MSM-12S-22X1.5	12	22X1.5	25	17.5	14	33.5	27	24
			HF-MSM-16S-18X1.5	16	18X1.5	26.5	18	12	36.5	27	30
			HF-MSM-20S-22X1.5	20	22X1.5	31	20.5	14	42	32	36
	HF-MSM-25S-27X2		25	27X2	35	23	16	47	41	46	
	HF-MSM-30S-33X2		30	33X2	37	23.5	18	50	46	50	

MALE STUD COUPLING WITH ELASTOMER SEAL

Thread BSP Parallel

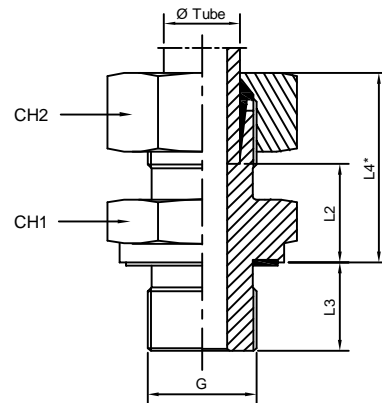
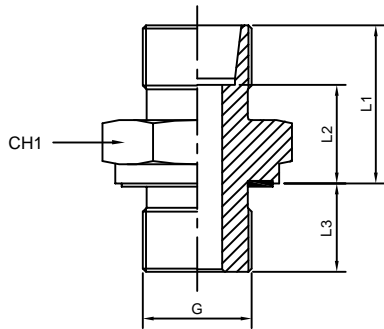

Series	W.P (Bar)	Part No.	Ø Tube	G	L1	L2	L3	L4*	CH1	CH2	
LL	100	HF-MSB-4LL-1/8-ED	4	1/8	13.5	9.5	8	20	14	10	
		HF-MSB-6LL-1/8-ED	6	1/8	13.5	8	8	20	14	12	
		HF-MSB-8LL-1/8-ED	8	1/8	14.5	9	8	21	14	14	
L	500	HF-MSB-6L-1/8-ED	6	1/8	15.5	8.5	8	23	14	14	
		HF-MSB-8L-1/4-ED	8	1/4	17	10	12	25	19	17	
		HF-MSB-10L-1/4-ED	10	1/4	18	11	12	12	26	19	19
	400	HF-MSB-12L-3/8-ED	12	3/8	19.5	12.5	12	12	27	22	22
		HF-MSB-15L-1/2-ED	15	1/2	21	14	14	14	29	27	27
		HF-MSB-18L-3/8-ED	18	3/8	22	14.5	12	12	31	27	32
	250	HF-MSB-18L-1/2-ED	18	1/2	22	14.5	14	14	31	27	32
		HF-MSB-22L-3/4-ED	22	3/4	24	16.5	16	16	33	32	36
		HF-MSB-28L-1-ED	28	1	25	17.5	18	18	34	41	41
		HF-MSB-28L-1 1/4-ED	28	1 1/4	25	17.5	20	20	34	50	41
		HF-MSB-35L-1 1/4-ED	35	1 1/4	28	17.5	20	20	39	50	50
		HF-MSB-35L-1 1/2-ED	35	1 1/2	28	17.5	22	22	39	55	50
S	800	HF-MSB-42L-1 1/2-ED	42	1 1/2	30	19	22	42	55	60	
		HF-MSB-6S-1/4-ED	6	1/4	20	13	12	28	19	17	
		HF-MSB-8S-1/4-ED	8	1/4	22	15	12	30	19	19	
	630	HF-MSB-10S-3/8-ED	10	3/8	22.5	15	12	31	22	22	
		HF-MSB-12S-3/8-ED	12	3/8	24.5	17	12	33	22	24	
		HF-MSB-14S-1/2-ED	14	1/2	27	19	14	37	27	27	
	420	HF-MSB-16S-1/2-ED	16	1/2	27	18.5	14	37	27	30	
		HF-MSB-20S-3/4-ED	20	3/4	31	20.5	16	42	32	36	
		HF-MSB-25S-1-ED	25	1	35	23	18	47	41	46	
L	500	HF-MSB-30S-1 1/4-ED	30	1 1/4	37	23.5	20	50	50	50	
		HF-MSB-38S-1 1/2-ED	38	1 1/2	42	26	22	57	55	60	
		HF-MSB-6L-1/4-ED	6	1/4	17	10	12	24.5	19	14	
	420	HF-MSB-8L-1/8-ED	8	1/8	16.5	9.5	8	24.5	14	17	
		HF-MSB-8L-3/8-ED	8	3/8	18.5	11.5	12	26.5	22	17	
		HF-MSB-8L-1/2-ED	8	1/2	19	12	14	27	27	17	
	400	HF-MSB-10L-1/8-ED	10	1/8	17.5	10.5	8	25.5	17	19	
		HF-MSB-10L-3/8-ED	10	3/8	19.5	12.5	12	27.5	22	19	
		HF-MSB-10L-1/2-ED	10	1/2	20	13	14	28	27	19	
		HF-MSB-12L-1/8-ED	12	1/8	19	12	8	26.5	17	22	
		HF-MSB-12L-1/4-ED	12	1/4	19	12	12	26.5	19	22	
		HF-MSB-12L-1/2-ED	12	1/2	20	13	14	27.5	27	22	
HF-MSB-12L-3/4-ED		12	3/4	22	15	16	30	32	22		
HF-MSB-15L-3/8-ED		15	3/8	20.5	13.5	12	28.5	24	27		
S	630	HF-MSB-18L-3/4-ED	18	3/4	22	14.5	16	31	32	32	
		HF-MSB-12S-1/2-ED	12	1/2	25	17.5	14	33.5	27	24	
		HF-MSB-14S-3/8-ED	14	3/8	26.5	18.5	12	36.5	24	27	
	420	HF-MSB-16S-3/8-ED	16	3/8	26.5	18	12	36.5	27	30	
		HF-MSB-20S-1/2-ED	20	1/2	31	20.5	14	42	32	36	
		HF-MSB-25S-3/4-ED	25	3/4	35	23	16	47	41	46	
		HF-MSB-30S-1-ED	30	1	37	23.5	18	50	46	50	
		HF-MSB-8S-3/8-ED	8	3/8	22.5	15.5	12	30.5	22	19	
		HF-MSB-10S-1/4-ED	10	1/4	22	14.5	12	30.5	19	22	
		HF-MSB-10S-1/2-ED	10	1/2	25	17.5	14	33.5	27	22	
		HF-MSB-12S-1/4-ED	12	1/4	24	16.5	12	32.5	22	24	
		HF-MSB-16S-3/4-ED	16	3/4	29	20.5	16	39	32	30	
HF-MSB-20S-1-ED	20	1	33	22.5	18	44	41	36			
L	250	HF-MSB-38S-1 1/4-ED	38	1 1/4	42	26	20	57	55	60	
		HF-MSB-15L-3/4-ED	15	3/4	22	15	16	30	32	27	
		HF-MSB-22L-1/2-ED	22	1/2	24	16.5	14	33	32	36	
		HF-MSB-22L-1-ED	22	1	25	17.5	18	34	41	36	
		HF-MSB-28L-3/4-ED	28	3/4	25	17.5	16	34	41	41	
		HF-MSB-35L-1-ED	35	1	28	17.5	18	39	46	50	
		HF-MSB-6L-3/8-ED	6	3/8	18.5	11.5	12	26	22	14	
		HF-MSB-42L-1-ED	42	1	30	19	18	42	55	60	
HF-MSB-42L-1 1/4-ED	42	1 1/4	30	19	20	42	55	60			

MALE STUD COUPLING WITH ELASTOMER SEAL

Thread Metric Parallel

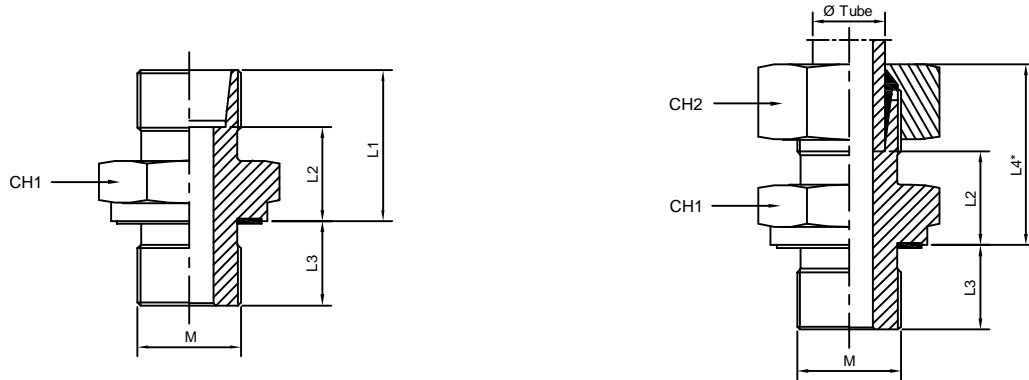

Series	W.P (Bar)	Part No.	Ø Tube	M	L1	L2	L3	L4*	CH1	CH2	
LL	100	HF-MSM-4LL-M8X1-ED	4	8x1	13.5	9.5	8	20	12	10	
		HF-MSM-6LL-M10X1-ED	6	10x1	13.5	8	8	20	14	12	
		HF-MSM-8LL-M10X1-ED	8	10x1	14.5	9	8	21	14	14	
L	315	HF-MSM-6L-M10X1-ED	6	10x1	15.5	8.5	8	23	14	14	
		HF-MSM-8L-M12X1.5-ED	8	12x1.5	17	10	12	25	17	17	
		HF-MSM-10L-M12X1.5-ED	10	12x1.5	18	11	12	26	17	19	
		HF-MSM-10L-M14X1.5-ED	10	14x1.5	18	11	12	26	19	19	
		HF-MSM-12L-M16X1.5-ED	12	16x1.5	19.5	12.5	12	27	22	22	
		HF-MSM-15L-M18X1.5-ED	15	18x1.5	20.5	13.5	12	29	24	27	
	160	HF-MSM-18L-M22X1.5-ED	18	22x1.5	22	14.5	14	31	27	32	
		HF-MSM-22L-M26X1.5-ED	22	26x1.5	24	16.5	16	33	32	36	
		HF-MSM-28L-M33X2-ED	28	33x2	25	17.5	18	34	41	41	
		HF-MSM-35L-M42X2-ED	35	42x2	28	17.5	20	39	50	50	
		HF-MSM-42L-M48X2-ED	42	48x2	30	19	22	42	55	60	
		HF-MSM-6S-M12X1.5-ED	6	12x1.5	20	13	12	28	17	17	
S	630	HF-MSM-8S-M14X1.5-ED	8	14x1.5	22	15	12	30	19	19	
		HF-MSM-10S-M16X1.5-ED	10	16x1.5	22.5	15	12	31	22	22	
		HF-MSM-12S-M18X1.5-ED	12	18x1.5	24.5	17	12	33	24	24	
		HF-MSM-14S-M20X1.5-ED	14	20x1.5	27	19	14	37	27	27	
	400	HF-MSM-16S-M22X1.5-ED	16	22x1.5	27	18.5	14	37	27	30	
		HF-MSM-20S-M27X2-ED	20	27x2	31	20.5	16	42	32	36	
		HF-MSM-25S-M33X2-ED	25	33x2	35	23	18	47	41	46	
		HF-MSM-30S-M42X2-ED	30	42x2	37	23.5	20	50	50	50	
	315	HF-MSM-38S-M48X2-ED	38	48x2	42	26	22	57	55	60	
	L	315	HF-MSM-8L-M18X1.5-ED	8	18x1.5	18.5	11.5	12	26.5	24	17
			HF-MSM-10L-M10X1.5-ED	10	16x1.5	19.5	12.5	12	27.5	22	19
			HF-MSM-10L-M18X1.5-ED	10	18x1.5	19.5	12.5	12	27.5	24	19
HF-MSM-10L-M22X1.5-ED			10	22x1.5	21	14	14	29	27	19	
HF-MSM-12L-M14X1.5-ED			12	14x1.5	19.5	11	12	27	19	22	
HF-MSM-12L-M18X1.5-ED			12	18x1.5	19.5	12.5	12	27	24	22	
HF-MSM-12L-M22X1.5-ED			12	22x1.5	21	14	14	28.5	27	22	
HF-MSM-15L-M16X1.5-ED			15	16x1.5	20	13	12	28	24	27	
HF-MSM-15L-M22X1.5-ED			15	22x1.5	22	15	14	30	27	27	
HF-MSM-18L-M18X1.5-ED			18	18x1.5	21.5	14	12	30.5	27	32	
HF-MSM-22L-M22X1.5-ED			22	22x1.5	24	16.5	14	33	32	36	
S			315	HF-MSM-12S-M22X1.5-ED	12	22x1.5	25	17.5	14	33.5	27
	HF-MSM-16S-M18X1.5-ED	16		18x1.5	26.5	18	12	36.5	27	30	
	HF-MSM-20S-M20X1.5-ED	20		22x1.5	31	20.5	14	42	32	36	
	HF-MSM-25S-M27X2-ED	25		27x2	35	23	16	47	41	46	
	HF-MSM-30S-M33X2-ED	30		33x2	37	23.5	18	50	46	50	
L		HF-MSM-8L-M10X1-ED	8	10x1	16.5	8.5	8	24	14	17	

FEMALE STUD COUPLING

Thread BSP Parallel - Thread Metric Parallel

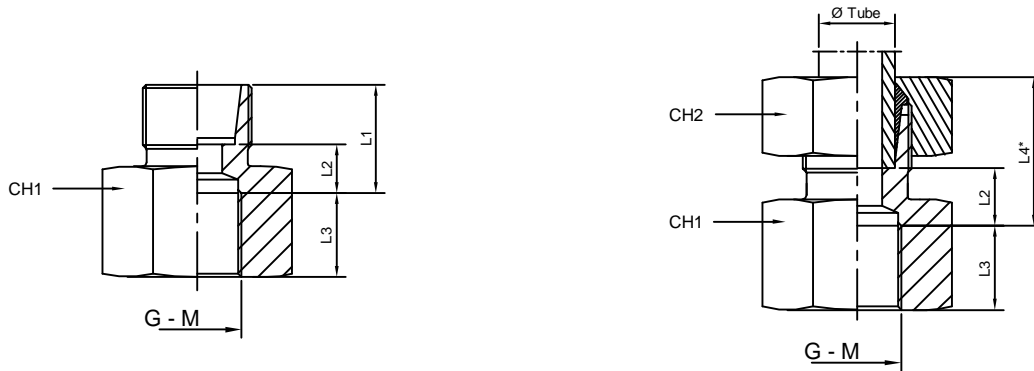

Series	W.P (Bar)	Part No.	Ø Tube	G	L1	L2	L3	L4*	CH1	CH2
L	315	HF-FSB-6L-1/8	6	1/8	16	9	10	23.5	14	14
		HF-FSB-8L-1/4	8	1/4	17	10	14	25	19	17
		HF-FSB-10L-1/4	10	1/4	18	11	14	26	19	19
		HF-FSB-12L-3/8	12	3/8	19	12	14	26.5	24	22
		HF-FSB-15L-1/2	15	1/2	21	14	17	29	27	27
	HF-FSB-18L-1/2	18	1/2	21	13.5	17	30	27	32	
	HF-FSB-22L-3/4	22	3/4	24	16.5	19	33	36	36	
	HF-FSB-28L-1	28	1	23.5	16	21.5	32.5	41	41	
	HF-FSB-35L-1 1/4	35	1 1/4	28.5	18	23.5	39.5	55	50	
HF-FSB-42L-1 1/2	42	1 1/2	28.5	17.5	25.5	40.5	60	60		
S	630	HF-FSB-6S-1/4	6	1/4	19	12	14	27	19	17
		HF-FSB-8S-1/4	8	1/4	19	12	14	27	19	19
		HF-FSB-10S-1/4	10	3/8	20	12.5	14	28.5	24	22
		HF-FSB-12S-3/8	12	3/8	20	12.5	14	28.5	24	24
		HF-FSB-14S-1/2	14	1/2	23	15	17	33	30	27
	400	HF-FSB-16S-1/2	16	1/2	23	14.5	17	33	30	30
		HF-FSB-20S-3/4	20	3/4	26	15.5	19	37	36	36
		HF-FSB-25S-1	25	1	27.5	15.5	21.5	39.5	41	46
		HF-FSB-30S-1 1/4	30	1 1/4	32.5	19	23.5	45.5	55	50
		HF-FSB-38S-1 1/2	38	1 1/2	34.5	18.5	25.5	49.5	60	60

Series	W.P (Bar)	Part No.	Ø Tube	M	L1	L2	L3	L4*	CH1	CH2
L	315	HF-FSB-6L-M10X1	6	10X1	16	9	10	23.5	14	14
		HF-FSB-8L-M12X1.5	8	12X1.5	16.5	9.5	14.5	24.5	17	17
		HF-FSB-10L-M14X1.5	10	14X1.5	17.5	10.5	14.5	25.5	19	19
		HF-FSB-12L-M16X1.5	12	16X1.5	18.5	11.5	14.5	26	22	22
		HF-FSB-15L-M18X1.5	15	18X1.5	23.5	16.5	14.5	31.5	24	27
	HF-FSB-18L-M22X1.5	18	22X1.5	21.5	14	16.5	30.5	30	32	
	HF-FSB-22L-M26X1.5	22	26X1.5	23.5	16	18.5	32.5	32	36	
	HF-FSB-28L-M33X2	28	33X2	24	16.5	21	33	41	41	
	HF-FSB-35L-M42X2	35	42X2	28	17.5	23	39	55	50	
HF-FSB-42L-M48X2	42	48X2	29	18	25	41	60	60		
S	630	HF-FSB-6S-M12X1.5	6	12X1.5	18.5	11.5	14.5	26.5	17	17
		HF-FSB-8S-M14X1.5	8	14X1.5	18.5	11.5	14.5	26.5	19	19
		HF-FSB-10S-M16X1.5	10	16X1.5	19.5	12	14.5	28	22	22
		HF-FSB-12S-M18X1.5	12	18X1.5	19.5	12	14.5	28	24	24
		HF-FSB-14S-M20X1.5	14	20X1.5	23.5	15.5	16.5	33.5	27	27
	400	HF-FSB-16S-M22X1.5	16	22X1.5	23.5	15	16.5	33.5	30	30
		HF-FSB-20S-M27X2	20	27X2	26	15.5	19	37	36	36
		HF-FSB-25S-M33X2	25	33X2	28	16	21	40	41	46
		HF-FSB-30S-M42X2	30	42X2	33	19.5	23	46	55	50
		HF-FSB-38S-M48X2	38	48X2	35	19	25	50	60	60

MALE STUD COUPLING

Thread UNF/UN-2A

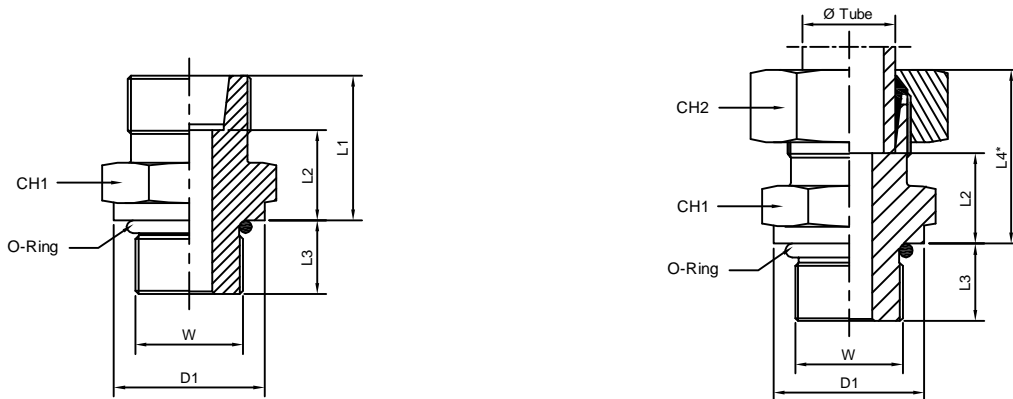

Series	W.P (Bar)	Part No.	Ø Tube	W	D1	L1	L2	L3	L4*	CH1	CH2
L	315	HF-MSU-6L-7/16	6	7/16-20	13.8	16.9	9.9	9.1	24.5	14	14
		HF-MSU-8L-1/2	8	1/2-20	16.8	16.9	9.9	9.1	25	17	17
		HF-MSU-10L-1/2	10	1/2-20	16.8	17.9	10.9	9.1	26	17	19
		HF-MSU-12L-9/16	12	9/16-18	18.8	18	11	10	25.5	19	22
		HF-MSU-15L-3/4	15	3/4-16	21.8	20.9	13.9	11.1	29	24	27
	HF-MSU-18L-3/4	18	3/4-16	21.8	21.9	14.4	11.1	31	27	32	
	160	HF-MSU-22L-1 1/16	22	1 1/16-12	31.8	23.9	16.4	15.1	33	32	36
		HF-MSU-28L-1 5/16	28	1 5/16-12	40.8	24.9	17.4	15.1	34	41	41
HF-MSU-35L-1 5/8		35	1 5/8-12	45.8	27.9	17.4	15.1	39	46	50	
S	630	HF-MSU-6S-1/2	6	1/2-20	16.8	21.9	14.9	9.1	30	17	17
		HF-MSU-8S-1/2	8	1/2-20	16.8	21.9	14.9	9.1	30	17	19
		HF-MSU-10S-9/16	10	9/16-18	18.8	22	14.5	10	30.5	19	22
		HF-MSU-12S-9/16	12	9/16-18	18.8	22	14.5	10	30.5	22	24
	400	HF-MSU-14S-3/4	14	3/4-16	21.8	23.9	15.9	11.1	34	24	27
		HF-MSU-16S-3/4	16	3/4-16	21.8	23.9	15.4	11.1	34	27	30
		HF-MSU-20S-1 1/16	20	1 1/16-12	31.8	30.9	20.4	15.1	42	32	36
		HF-MSU-25S-1 5/16	25	1 5/16-12	40.8	34.9	22.9	15.1	47	41	46
		HF-MSU-30S-1 5/8	30	1 5/8-12	49.8	36.9	23.4	15.1	50	50	50
		HF-MSU-38S-1 7/8	38	1 7/8-12	54.8	41.9	25.9	15.1	57	55	60
L	315	HF-MSU-8L-7/16	8	7/16-20	13.8	16.9	9.9	9.1	25	14	17
		HF-MSU-10L-7/16	10	7/16-20	13.8	17.9	10.9	9.1	26	17	19
		HF-MSU-12L-3/4	12	3/4-16	21.8	19.9	12.9	11.1	27.5	22	22
		HF-MSU-12L-7/8	12	7/8-14	26.8	21.3	14.3	12.7	29	27	22
	160	HF-MSU-18L-7/8	18	7/8-14	26.8	22.3	14.8	12.7	31.5	27	32
		HF-MSU-22L-7/8	22	7/8-14	26.8	24.3	16.8	12.7	33.5	32	36
		HF-MSU-22L-1 5/16	22	1 5/16-12	40.8	24.9	17.4	15.1	34	41	36
		HF-MSU-28L-1 1/16	28	1 1/16-12	31.8	24.9	17.4	15.1	34	41	41
S	630	HF-MSU-38L-1 5/8	38	1 5/8-12	49.8	29.9	18.9	15.1	42	55	60
		HF-MSU-42L-1 5/8	42	1 5/8-12	49.8	29.9	18.9	15.1	42	55	60
	400	HF-MSU-8S-7/16	8	7/16-20	13.8	21.9	14.9	9.1	30	17	19
		HF-MSU-12S-3/4	12	3/4-16	21.8	24.9	17.4	11.1	33.5	22	24
		HF-MSU-16S-7/8	16	7/8-14	26.8	27.3	18.8	12.7	37.5	27	30
		HF-MSU-20S-3/4	20	3/4-16	21.8	30.9	20.4	11.1	42	32	36
315	HF-MSU-20S-7/8	20	7/8-14	26.8	31.3	20.8	12.7	42.5	32	36	
	HF-MSU-25S-1 5/16	25	1 5/16-12	31.8	34.9	22.9	15.1	47	36	46	
HF-MSU-30S-1 1/16	30	1 1/16-12	40.8	36.9	23.4	15.1	50	46	50		
HF-MSU-38S-1 5/8	38	1 5/8-12	49.8	41.9	25.9	15.1	57	55	60		

BANJO COUPLING WITH BONDED SEAL/COPPER WASHER

Thread BSP Parallel

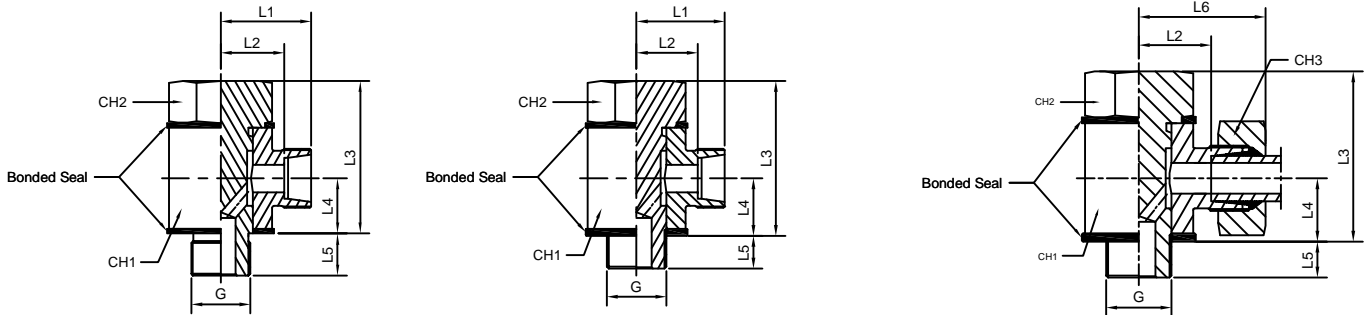

Series	W.P (Bar)	Part No.	Ø Tube	G	L1	L2	L3	L4*	L5	L6	CH1	CH2	CH3
LL	100	HF-APC-4LL-1/8	4	1/8	18	14	24	10.5	8	24	17	17	10
		HF-APC-6LL-1/8	6	1/8	18	12.5	24	10.5	8	24	17	17	12
		HF-APC-8LL-1/8	8	1/8	19	13.5	24	10.5	8	25	17	17	14
L	315	HF-APC-6L-1/8	6	1/8	19	12	24	10.5	8	27	17	17	14
		HF-APC-8L-1/4	8	1/4	21.5	14.5	32	14	12	29.5	22	19	17
		HF-APC-10L-1/4	10	1/4	22.5	15.5	32	14	12	30.5	22	19	19
		HF-APC-12L-3/8	12	3/8	25	18	38.5	16.5	12	33	27	24	22
		HF-APC-15L-1/2	15	1/2	29	22	46.5	21.5	14	37	32	30	27
		HF-APC-18L-1/2	18	1/2	29	21.5	46.5	21.5	14	38	32	30	32
	160	HF-APC-22L-3/4	22	3/4	34	26.5	54	24	16	43	41	36	36
		HF-APC-28L-1	28	1	38.5	31	66.5	30.5	18	47.5	50	46	41
		HF-APC-35L-1 1/4	35	1 1/4	45.5	35	80	35.5	20	56.5	60	55	50
		HF-APC-42L-1 1/2	42	1 1/2	50.5	39.5	90	40.5	22	62.5	70	60	60
S	400	HF-APC-6S-1/4	6	1/4	23.5	16.5	32	14	12	31.5	22	19	17
		HF-APC-8S-1/4	8	1/4	23.5	16.5	32	14	12	31.5	22	19	19
		HF-APC-10S-3/8	10	3/8	26	18.5	38.5	16.5	12	35	27	24	22
	315	HF-APC-12S-3/8	12	3/8	26	18.5	38.5	16.5	12	35	27	24	24
		HF-APC-14S-1/2	14	1/2	31	23	46.5	21.5	14	41	32	30	27
		HF-APC-16S-1/2	16	1/2	31	22.5	46.5	21.5	14	41	32	30	30
	250	HF-APC-20S-3/4	20	3/4	36	25.5	54	24	16	47	41	36	36
		HF-APC-25S-1	25	1	42.5	30.5	66.5	30.5	18	54.5	50	46	46
		HF-APC-30S-1 1/4	30	1 1/4	49.5	36	80	35.5	20	62.5	60	50	50
200	HF-APC-38S-1 1/2	38	1 1/2	56.5	40.5	90	40.5	22	71.5	70	60	60	
LL	100	HF-APC-4LL-1/8	4	1/8	17.5	13.5	21.5	10	6	23.5	14	10	10
		HF-APC-6LL-1/8	6	1/8	17.5	12	21.5	10	6	23.5	14	12	12
		HF-APC-8LL-1/8	8	1/8	18.5	13	21.5	10	6	24.5	14	14	14
L	250	HF-APC-6L-1/8	6	1/8	18.5	11.5	21.5	10	6	26.5	14	14	14
		HF-APC-8L-1/4	8	1/4	21	14	27.5	13	9	29	19	17	17
		HF-APC-10L-1/4	10	1/4	22	15	27.5	13	9	30	19	19	19
		HF-APC-12L-3/8	12	3/8	24	17	32.5	15	9	32	22	22	22
		HF-APC-15L-1/2	15	1/2	27	20	45	21.5	10	35	30	27	27
		HF-APC-18L-1/2	18	1/2	27	19.5	45	21.5	10	36	30	32	32
S	250	HF-APC-22L-3/4	22	3/4	33	25.5	48	23	13	42	36	36	36
		HF-APC-6S-1/4	6	1/4	23	16	27.5	13	9	31	19	17	17
		HF-APC-8S-1/4	8	1/4	23	16	27.5	13	9	31	19	19	19
		HF-APC-10S-3/8	10	3/8	25	17.5	32.5	15	9	34	22	22	22
		HF-APC-12S-3/8	12	3/8	25	17.5	32.5	15	9	34	22	24	24
		HF-APC-14S-1/2	14	1/2	29	21	45	21.5	10	39	30	27	27
	160	HF-APC-16S-1/2	16	1/2	29	20.5	45	21.5	10	39	30	30	30
		HF-APC-20S-3/4	20	3/4	35	24.5	48	23	13	46	36	36	36

BANJO COUPLING WITH BONDED SEAL/COPPER WASHER

Thread Metric Parallel

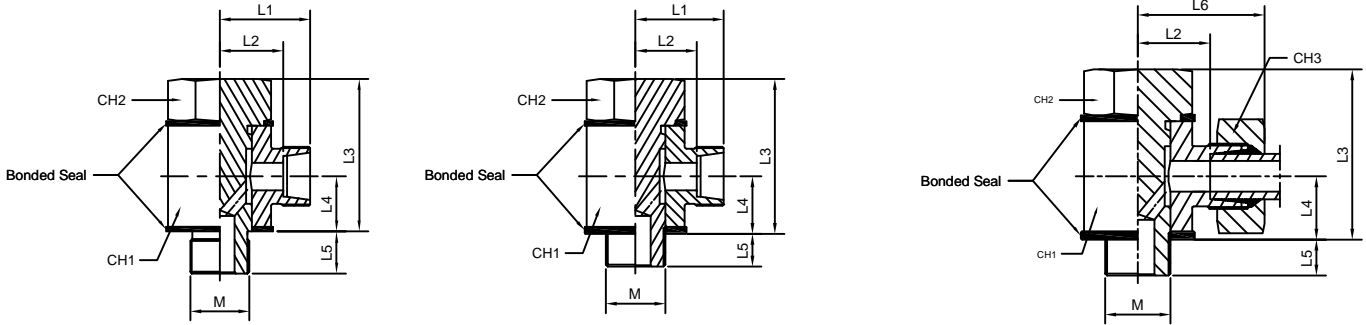

Series	W.P (Bar)	Part No.	Ø Tube	M	L1	L2	L3	L4*	L5	L6	CH1	CH2	CH3
LL	100	HF-APC-4LL-M8X1	4	8X1	18	14	24	10.5	8	24	17	14	10
		HF-APC-6LL-M10X1	6	10X1	18	12.5	24	10.5	8	24	17	17	12
		HF-APC-8LL-M10X1	8	10X1	19	13.5	24	10.5	8	25	17	17	14
L	315	HF-APC-6L-M10X1	6	10X1	19	12	24	10.5	8	27	17	17	14
		HF-APC-8L-M12X1.5	8	12X1.5	21.5	14.5	32	14	12	29.5	22	19	17
		HF-APC-10L-M14X1.5	10	14X1.5	22.5	15.5	32	14	12	30.5	22	19	19
		HF-APC-12L-M16X1.5	12	16X1.5	25	18	38.5	16.5	12	33	27	24	22
		HF-APC-15L-M18X1.5	15	18X1.5	29	22	42	18.5	12	37	32	27	27
		HF-APC-18L-M22X1.5	18	22X1.5	29	21.5	46.5	21.5	14	38	32	30	32
	160	HF-APC-22L-M26X1.5	22	26X1.5	34	26.5	54	24	16	43	41	36	36
		HF-APC-28L-M33X2	28	33X2	38.5	31	66.5	30.5	18	47.5	50	46	41
		HF-APC-35L-M42X2	35	42X2	45.5	35	80	35.5	20	56.5	60	55	50
S	400	HF-APC-42L-M48X2	42	48X2	50.5	39.5	90	40.5	22	62.5	70	60	60
		HF-APC-6S-M12X1.5	6	12X1.5	23.5	16.5	32	14	12	31.5	22	19	17
		HF-APC-8S-M14X1.5	8	14X1.5	23.5	16.5	32	14	12	31.5	22	19	19
		HF-APC-10S-M16X1.5	10	16X1.5	26	18.5	38.5	16.5	12	35	27	24	22
	315	HF-APC-12S-M18X1.5	12	18X1.5	29	21.5	42	18.5	12	38	32	27	24
		HF-APC-14S-M20X1.5	14	20X1.5	31	23	45	20	14	41	32	30	27
		HF-APC-16S-M22X1.5	16	22X1.5	31	22.5	46.5	21.5	14	41	32	30	30
		HF-APC-20S-M27X2	20	27X2	36	25.5	54	24	16	47	41	36	36
	250	HF-APC-25S-M33X2	25	33X2	42.5	31.5	66.5	30.5	18	54.5	50	46	46
		HF-APC-30S-M42X2	30	42X2	49.5	36	80	35.5	20	62.5	60	55	50
		HF-APC-38S-M48X2	38	48X2	56.5	40.5	90	40.5	22	71.5	70	60	60
		HF-APC-4LL-M8X1	4	8X1	17.5	13.5	21.5	10	6	23.5	14	12	10
LL	100	HF-APC-6LL-M10X1	6	10X1	17.5	12	21.5	10	6	23.5	14	14	12
		HF-APC-8LL-M10X1	8	10X1	18.5	13	21.5	10	6	24.5	14	14	14
		HF-APC-6L-M10X1	6	10X1	18.5	11.5	21.5	10	6	26.5	14	14	14
L	250	HF-APC-8L-M12X1.5	8	12X1.5	21	14	27.5	13	9	29	19	17	17
		HF-APC-10L-M14X1.5	10	14X1.5	22	15	27.5	13	9	30	19	19	19
		HF-APC-12L-M16X1.5	12	16X1.5	24	17	32.5	15	9	32	22	22	22
		HF-APC-15L-M18X1.5	15	18X1.5	25	18	37	17	9	33	24	24	27
	160	HF-APC-18L-M22X1.5	18	22X1.5	27	19.5	45	21.5	10	36	30	27	32
		HF-APC-22L-M26X1.5	22	26X1.5	33	25.5	48	23	13	42	36	32	36
S	250	HF-APC-6L-M12X1.5	6	12X1.5	23	16	27.5	13	9	31	19	17	17
		HF-APC-8L-M14X1.5	8	14X1.5	23	16	27.5	13	9	31	19	19	19
		HF-APC-10L-M16X1.5	10	16X1.5	25	17.5	32.5	15	9	34	22	22	22
		HF-APC-12L-M18X1.5	12	18X1.5	25	17.5	37	15	9	34	24	24	24
	160	HF-APC-14L-M20X1.5	14	20X1.5	28	20	45	21.5	10	38	27	27	27
		HF-APC-16L-M22X1.5	16	22X1.5	29	20.5	45	21.5	10	39	30	27	30
		HF-APC-20L-M27X2	20	27X2	35	24.5	48	23	13	46	36	32	36

BANJO TEE COUPLING WITH BONDED SEAL/COPPER WASHER

Thread BSP Parallel - Thread Metric Parallel

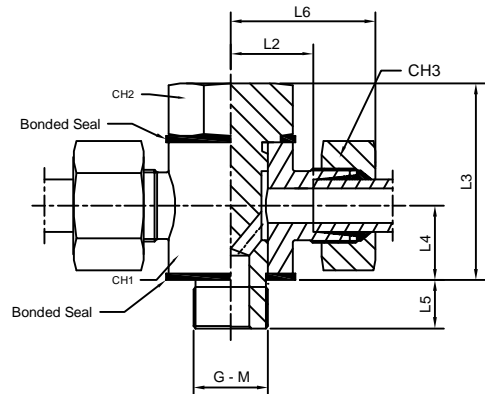
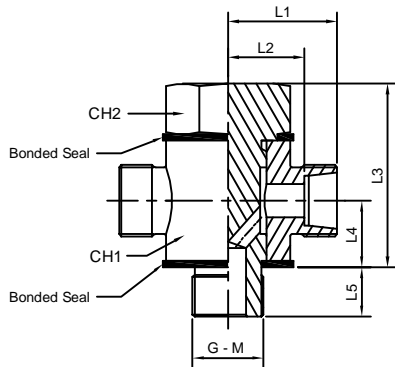

Series	W.P (Bar)	Part No.	Ø Tube	G	L1	L2	L3	L4	L5	L6	CH1	CH2	CH3
L	315	HF-APCT-6L-1/8	6	1/8	19	12	24	10.5	8	27	17	17	14
		HF-APCT-8L-1/4	8	1/4	21.5	14.5	32	14	12	29.5	22	19	17
		HF-APCT-10L-1/4	10	1/4	22.5	15.5	32	14	12	30.5	22	19	19
		HF-APCT-12L-3/8	12	3/8	25	18	38.5	16.5	12	33	27	24	22
	160	HF-APCT-15L-1/2	15	1/2	29	22	46.5	21.5	14	37	32	30	27
		HF-APCT-18L-1/2	18	1/2	29	21.5	46.5	21.5	14	38	32	30	32
		HF-APCT-22L-3/4	22	3/4	34	26.5	54	24	16	43	41	36	36
		HF-APCT-28L-1	28	1	38.5	31	66.5	30.5	18	47.5	50	46	41
S	400	HF-APCT-35L-1 1/4	35	1 1/4	45.5	35	80	35.5	20	56.5	60	55	50
		HF-APCT-42L-1 1/2	42	1 1/2	50.5	39.5	90	40.5	22	62.5	70	60	60
		HF-APCT-6S-1/4	6	1/4	23.5	16.5	32	14	12	31.5	22	19	17
		HF-APCT-8S-1/4	8	1/4	23.5	16.5	32	12	12	31.5	22	19	19
S	315	HF-APCT-10S-3/8	10	3/8	26	18.5	38.5	16.5	12	35	27	24	22
		HF-APCT-12S-3/8	12	3/8	26	18.5	38.5	16.5	12	35	27	24	24
		HF-APCT-14S-1/2	14	1/2	31	23	46.5	21.5	14	41	32	30	27
		HF-APCT-16S-1/2	16	1/2	31	22.5	46.5	21.5	14	41	32	30	30
	250	HF-APCT-20S-3/4	20	3/4	36	25.5	54	24	16	47	41	36	36
		HF-APCT-25S-1	25	1	42.5	30.5	66.5	30.5	18	54.5	50	46	46
		HF-APCT-30S-1 1/4	30	1 1/4	49.5	36	80	35.5	20	62.5	60	55	50
		HF-APCT-38S-1 1/2	38	1 1/2	56.5	40.5	90	40.5	22	71.5	70	60	60

Series	W.P (Bar)	Part No.	Ø Tube	M	L1	L2	L3	L4	L5	L6	CH1	CH2	CH3
L	315	HF-APCT-6L-M10X1	6	10X1	19	12	24	10.5	8	27	17	17	14
		HF-APCT-8L-M12X1.5	8	12X1.5	21.5	14.5	32	14	12	29.5	22	19	17
		HF-APCT-10L-M14X1.5	10	14X1.5	22.5	15.5	32	14	12	30.5	22	19	19
		HF-APCT-12L-M16X1.5	12	16X1.5	25	18	38.5	16.5	12	33	27	24	22
	160	HF-APCT-15L-M18X1.5	15	18X1.5	29	22	42	18.5	12	37	32	27	27
		HF-APCT-18L-M22X1.5	18	22X1.5	29	21.5	46.5	21.5	14	38	32	30	32
		HF-APCT-22L-M26X1.5	22	26X1.5	34	26.5	54	24	16	43	41	36	36
		HF-APCT-28L-M33X2	28	33X2	38.5	31	66.5	30.5	18	47.5	50	46	41
S	400	HF-APCT-35L-M42X2	35	42X2	45.5	35	80	35.5	20	56.5	60	55	50
		HF-APCT-42L-M48X2	42	48X2	50.5	39.5	90	40.5	22	62.5	70	60	60
		HF-APCT-6S-M12X1.5	6	12X1.5	23.5	16.5	32	14	12	31.5	22	19	17
		HF-APCT-8S-M14X1.5	8	14X1.5	23.5	16.5	32	14	12	31.5	22	19	19
	315	HF-APCT-10S-M16X1.5	10	16X1.5	26	18.5	38.5	16.5	12	35	27	24	22
		HF-APCT-12S-M18X1.5	12	18X1.5	29	21.5	42	18.5	12	38	32	27	24
		HF-APCT-14S-M20X1.5	14	20X1.5	31	23	45	20	14	41	32	30	27
		HF-APCT-16S-M22X1.5	16	22X1.5	31	22.5	46.5	21.5	14	41	32	30	30
250	HF-APCT-20S-M27X2	20	27X2	36	25.5	54	24	16	47	41	36	36	
	HF-APCT-25S-M33X2	25	33X2	42.5	31.5	66.5	30.5	18	54.5	50	46	46	
	HF-APCT-30S-M42X2	30	42X2	49.5	36	80	35.5	20	62.5	60	55	50	
	HF-APCT-38S-M48X2	38	48X2	56.5	40.5	90	40.5	22	71.5	70	60	60	

MALE STUD COUPLING

Thread BSP Taper



Series	W.P (Bar)	Part No.	Ø Tube	G	L1	L2	L3	L4	CH1	CH2
LL	100	HF-MST-4LL-1/8	4	1/8	12	8	8	18.5	12	10
		HF-MST-6LL-1/8	6	1/8	12	6.5	8	18.5	12	12
		HF-MST-8LL-1/8	8	1/8	14	8.5	8	20.5	12	14
L	315	HF-MST-6L-1/8	6	1/8	14	7	8	22	12	14
		HF-MST-8L-1/4	8	1/4	15	8	12	23	17	17
		HF-MST-10L-1/4	10	1/4	16	9	12	24	17	19
		HF-MST-12L-3/8	12	3/8	17	10	12	24.5	19	22
		HF-MST-15L-1/2	15	1/2	18	11	14	26	24	27
		HF-MST-18L-1/2	18	1/2	19	11.5	14	28	27	32
	160	HF-MST-22L-3/4	22	3/4	21	13.5	16	30	32	36
		HF-MST-28L-1	28	1	22	14.5	18	31	41	41
		HF-MST-35L-1 1/4	35	1 1/4	25	14.5	20	36	46	50
		HF-MST-42L-1 1/2	42	1 1/2	27	16	22	39	55	60
S	630	HF-MST-6S-1/4	6	1/4	18	11	12	26	17	17
		HF-MST-8S-1/4	8	1/4	20	13	12	28	17	19
		HF-MST-10S-3/8	10	3/8	20	12.5	12	28.5	19	22
		HF-MST-12S-3/8	12	3/8	22	14.5	12	30.5	22	24
		HF-MST-14S-1/2	14	1/2	24	16	14	34	24	27
		HF-MST-16S-1/2	16	1/2	24	15.5	14	34	27	30
	400	HF-MST-20S-3/4	20	3/4	28	17.5	16	39	32	36
		HF-MST-25S-1	25	1	32	20	18	44	41	46
		HF-MST-30S-1 1/4	30	1 1/4	34	20.5	20	47	46	50
		HF-MST-38S-1 1/2	38	1 1/2	39	23	22	54	55	60
L	315	HF-MST-6L-1/4	6	1/4	15	8	12	22.5	14	14
		HF-MST-8L-1/8	8	1/8	15	8	8	22	14	17
		HF-MST-8L-3/8	8	3/8	16	9	12	25	19	17
		HF-MST-8L-1/2	8	1/2	16	9	14	25	22	17
		HF-MST-10L-1/8	10	1/8	16	9	8	24	17	19
		HF-MST-10L-3/8	10	3/8	17	10	12	25	19	19
		HF-MST-10L-1/2	10	1/2	17	10	14	25	22	19
		HF-MST-12L-1/4	12	1/4	17	10	12	24.5	19	22
		HF-MST-12L-1/2	12	1/2	17	10	14	24.5	22	22
		HF-MST-15L-3/8	15	3/8	18	11	12	26	24	27
S	630	HF-MST-12S-1/2	12	1/2	22	14.5	14	30.5	22	24
		HF-MST-14S-3/8	14	3/8	24	16	12	34	24	27
	400	HF-MST-16S-3/8	16	3/8	24	15.5	12	34	27	30
		HF-MST-20S-1/2	20	1/2	28	17.5	14	39	32	36
		HF-MST-25S-3/4	25	3/4	32	20	16	44	41	46
		HF-MST-30S-1	30	1	34	20.5	18	47	46	50

MALE STUD COUPLING

Thread BSP Parallel

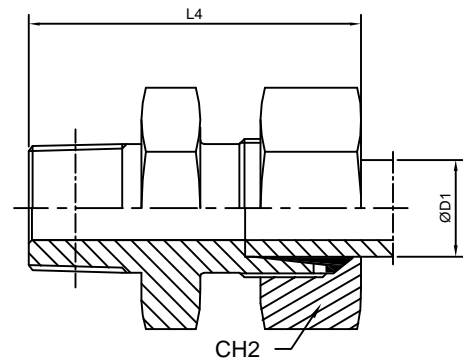
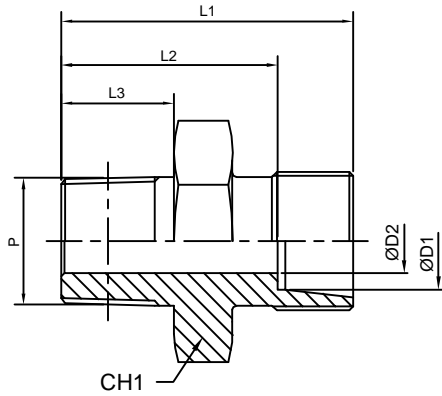

Series	W.P (Bar)	Part No.	Ø Tube		P (NPT)	L1	L2	L3	L4*	CH1	CH2
			D1	D2							
LL	100	HF-MSN-4LL-1/8	4	3	1/8-27	22	18	10	28	11	10
		HF-MSN-6LL-1/8	6	4.5	1/8-27	22	16.5	10	28	11	12
		HF-MSN-8LL-1/8	8	5	1/8-27	24	18.5	10	30	12	14
L	315	HF-MSN-6L-1/8	6	4	1/8-27	24	17	10	32	12	14
		HF-MSN-6L-1/4	6	4	1/4-18	30	23	14.5	38	17	14
		HF-MSN-6L-3/8	6	4	3/8-18	30	23	14.5	38	19	14
		HF-MSN-6L-1/2	6	4	1/2-14	36	29	19.5	44	22	14
	315	HF-MSN-8L-1/8	8	4	1/8-27	25	18	10	33	14	17
		HF-MSN-8L-1/4	8	6	1/4-18	30	23	14.5	38	17	17
		HF-MSN-8L-3/8	8	6	3/8-18	30	23	14.5	38	19	17
		HF-MSN-8L-1/2	8	6	1/2-14	36	29	19.5	44	22	17
	315	HF-MSN-10L-1/8	10	4	1/8-27	25	18	10	33	17	19
		HF-MSN-10L-1/4	10	7	1/4-18	31	24	14.5	39	17	19
		HF-MSN-10L-3/8	10	7	3/8-18	32	25	14.5	40	19	19
		HF-MSN-10L-1/2	10	8	1/2-14	37	30	19.5	45	22	19
	315	HF-MSN-10L-3/4	10	8	3/4-14	38	31	19.5	46	30	19
		HF-MSN-12L-1/8	12	4	1/8-27	26	19	10	34	19	22
		HF-MSN-12L-1/4	12	7	1/4-18	32	25	14.5	40	19	22
		HF-MSN-12L-3/8	12	8	3/8-18	32	25	14.5	40	19	22
	315	HF-MSN-12L-1/2	12	10	1/2-14	37	30	19.5	45	22	22
		HF-MSN-12L-3/4	13	10	3/4-14	39	32	19.5	47	30	22
		HF-MSN-15L-3/8	15	8	3/8-18	33	26	14.5	41	24	27
		HF-MSN-15L-1/2	15	12	1/2-14	38	31	19.5	46	24	27
	315	HF-MSN-15L-3/4	15	12	3/4-14	39	32	19.5	47	30	27
		HF-MSN-15L-1	15	12	1-11 1/2	45	38	24.5	53	36	27
		HF-MSN-18L-3/8	18	8	3/8-18	34	26.5	14.5	43	27	32
		HF-MSN-18L-1/2	18	12	1/2-14	39	31.5	19.5	48	27	32
	315	HF-MSN-18L-3/4	18	15	3/4-14	39	31.5	19.5	48	30	32
		HF-MSN-18L-1	18	15	1-11 1/2	45	37.5	24.5	54	36	32
		HF-MSN-22L-3/8	22	8	3/8-18	36.5	29	14.5	45	32	36
		HF-MSN-22L-1/2	22	12	1/2-14	41	33.5	19.5	50	32	36
	160	HF-MSN-22L-3/4	22	16	3/4-14	41	33.5	19.5	50	32	36
		HF-MSN-22L-1	22	19	1-11 1/2	47	39.5	24.5	56	36	36
		HF-MSN-28L-3/4	28	16	3/4-14	42	34.5	19.5	51	41	41
		HF-MSN-28L-1	28	21	1-11 1/2	47	39.5	24.5	56	41	41
	160	HF-MSN-28L-1 1/4	28	24	1 1/4-11 1/2	49	41.5	25	48	46	41
		HF-MSN-35L-1	35	22	1-11 1/2	50	39.5	24.5	61	46	50
		HF-MSN-35L-1 1/4	35	28	1 1/4-11 1/2	51	40.5	25	62	46	50
		HF-MSN-35L-1 1/2	35	28	1 1/2-11 1/2	53	42	26	65	55	50
160	HF-MSN-42L-1 1/4	42	28	1 1/4-11 1/2	53	42	25	65	55	60	
	HF-MSN-42L-1 1/2	42	36	1 1/2-11 1/2	53	42	26	65	55	60	

MALE STUD COUPLING

Thread BSP Parallel

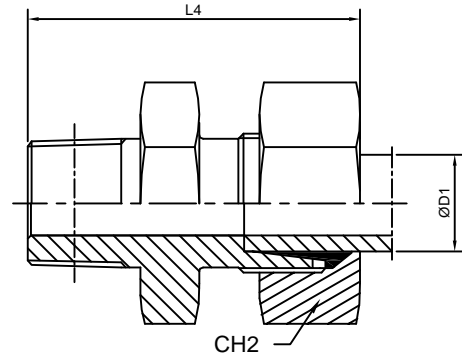
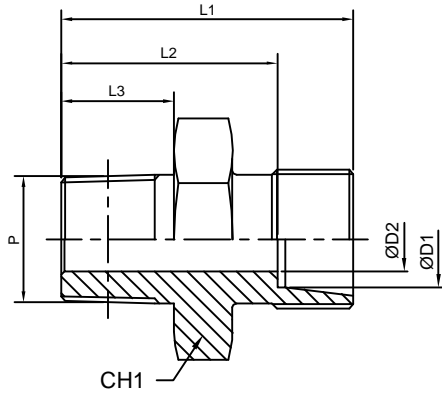

Series	W.P (Bar)	Part No.	Ø Tube		P (NPT)	L1	L2	L3	L4*	CH1	CH2
			D1	D2							
S	630	HF-MSN-6S-1/8	6	4	1/8-27	28	21	10	36	14	17
		HF-MSN-6S-1/4	6	4	1/4-18	35	28	14.5	43	17	17
		HF-MSN-6S-3/8	6	4	3/8-18	33	26	14.5	41	19	17
		HF-MSN-6S-1/2	6	4	1/2-14	42	35	19.5	50	22	17
	630	HF-MSN-8S-1/4	8	5	1/4-18	35	28	14.5	43	17	19
		HF-MSN-8S-3/8	8	5	3/8-18	35	28	14.5	43	19	19
		HF-MSN-8S-1/2	8	5	1/2-14	42	35	19.5	50	22	19
		HF-MSN-10S-1/4	10	5	1/4-18	35	27	14.5	44	19	22
	630	HF-MSN-10S-3/8	10	7	3/8-18	35	27	14.5	44	19	22
		HF-MSN-10S-1/2	10	7	1/2-14	42	34	19.5	51	22	22
		HF-MSN-10S-3/4	10	7	3/4-14	44	36	19.5	53	30	22
		HF-MSN-12S-1/4	12	5	1/4-18	37	29	14.5	46	22	24
	630	HF-MSN-12S-3/8	12	8	3/8-18	37	29	14.5	46	22	24
		HF-MSN-12S-1/2	12	8	1/2-14	42	34	19.5	51	22	24
		HF-MSN-12S-3/4	12	8	3/4-14	44	36	19.5	53	30	24
		HF-MSN-14S-3/8	14	8	3/8-18	39	31	14.5	49	24	27
	630	HF-MSN-14S-1/2	14	10	1/2-14	44	36	19.5	54	24	27
		HF-MSN-14S-3/4	14	10	3/4-14	46	38	19.5	56	30	27
		HF-MSN-14S-1	14	10	1-11 1/2	51	43	24.5	61	36	27
		HF-MSN-16S-3/8	16	8	3/8-18	39	30.5	14.5	49	27	30
	400	HF-MSN-16S-1/2	16	12	1/2-14	48	39.5	19.5	58	32	30
		HF-MSN-16S-3/4	16	12	3/4-14	46	37.5	19.5	56	30	30
		HF-MSN-16S-1	16	12	1-11 1/2	51	42.5	24.5	61	36	30
		HF-MSN-20S-1/2	20	12	1/2-14	48	37.5	19.5	59	32	36
	400	HF-MSN-20S-3/4	20	16	3/4-14	48	37.5	19.5	59	32	36
		HF-MSN-20S-1	20	16	1-11 1/2	55	44.5	24.5	66	36	36
		HF-MSN-25S-3/4	25	16	3/4-14	52	40	19.5	64	41	46
		HF-MSN-25S-1	25	20	1-11 1/2	57	45	24.5	69	41	46
	400	HF-MSN-25S-11/4	25	20	11/4-11 1/2	58	46	25	70	46	46
		HF-MSN-25S-11/2	25	20	11/2-11 1/2	61	49	26	73	50	46
HF-MSN-30S-3/4		30	16	3/4-14	54	40.5	19.5	67	46	50	
HF-MSN-30S-1		30	20	1-11 1/2	59	45.5	24.5	72	46	50	
315	HF-MSN-30S-11/4	30	25	11/4-11 1/2	60	46.5	25	73	46	50	
	HF-MSN-30S-11/2	30	25	11/2-11 1/2	60	46.5	26	73	50	50	
	HF-MSN-38S-1	38	22	1-11 1/2	64	48	24.5	79	55	60	
	HF-MSN-38S-11/4	38	25	11/4-11 1/2	65	49	25	80	55	60	
		HF-MSN-38S-11/2	38	32	11/2-1 1/2	65	49	26	80	55	60

MALE STUD ELBOW
Thread BSP Tapper

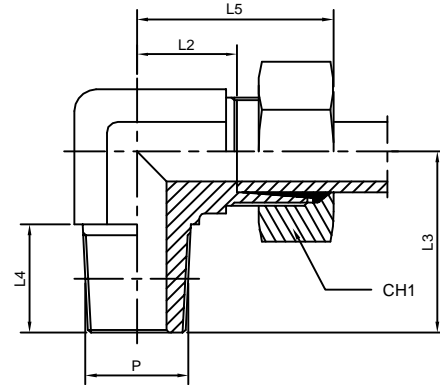
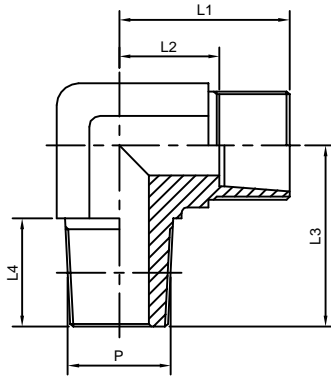

Series	W.P (Bar)	Part No.	Ø Tube	P	L1	L2	L3	L4	L5	CH1
LL	100	HF-ECT-4LL-1/8	4	1/8	15	11	17	8	21	10
		HF-ECT-6LL-1/8	6	1/8	15	9.5	17	8	21	12
		HF-ECT-8LL-1/8	8	1/8	17	11.5	20	8	23	14
L	315	HF-ECT-6L-1/8	6	1/8	19	12	20	8	27	14
		HF-ECT-8L-1/4	8	1/4	21	14	26	12	29	17
		HF-ECT-10L-1/4	10	1/4	22	15	27	12	30	19
		HF-ECT-12L-3/8	12	3/8	24	17	28	12	32	22
		HF-ECT-15L-1/2	15	1/2	28	21	34	14	36	27
		HF-ECT-18L-1/2	18	1/2	31	23.5	36	14	40	32
	160	HF-ECT-22L-3/4	22	3/4	35	27.5	42	16	44	36
		HF-ECT-28L-1	28	1	38	30.5	48	18	47	41
		HF-ECT-35L-1 1/4	35	1 1/4	45	34.5	57	20	56	50
		HF-ECT-42L-1 1/2	42	1 1/2	51	40	61	22	63	60
S	630	HF-ECT-6S-1/4	6	1/4	23	16	26	12	31	17
		HF-ECT-8S-1/4	8	1/4	24	17	27	12	32	19
		HF-ECT-10S-3/8	10	3/8	25	17.5	28	12	34	22
		HF-ECT-12S-3/8	12	3/8	29	21.5	28	12	38	24
		HF-ECT-14S-1/2	14	1/2	30	22	32	14	40	27
		HF-ECT-16S-1/2	16	1/2	33	24.5	32	14	43	30
	400	HF-ECT-20S-3/4	20	3/4	37	26.5	42	16	48	36
		HF-ECT-25S-1	25	1	42	30	48	18	54	46
		HF-ECT-30S-1 1/4	30	1 1/4	49	35.5	54	20	62	50
		HF-ECT-38S-1 1/2	38	1 1/2	57	41	61	22	72	60
L	315	HF-ECT-6L-1/4	6	1/4	21	14	26	12	29	14
		HF-ECT-8L-1/8	8	1/8	21	14	22	8	29	17
		HF-ECT-8L-3/8	8	3/8	23	16	28	12	31	17
		HF-ECT-8L-1/2	8	1/2	26	19	34	14	34	17
		HF-ECT-10L-1/8	10	1/8	22	15	22	8	30	19
		HF-ECT-10L-3/8	10	3/8	24	17	28	12	32	19
		HF-ECT-10L-1/2	10	1/2	27	20	34	14	35	19
		HF-ECT-12L-1/4	12	1/4	24	17	28	12	32	22
		HF-ECT-12L-1/2	12	1/2	27	20	34	14	34	22
		HF-ECT-15L-3/8	15	3/8	28	21	30	12	36	27
HF-ECT-18L-3/4	18	3/4	34	26.5	42	16	43	32		
S	315	HF-ECT-12S-1/2	12	1/2	28	20.5	34	14	37	24
		HF-ECT-14S-3/8	14	3/8	30	22	30	12	40	27
		HF-ECT-16S-3/8	16	3/8	33	24.5	37	12	43	30
		HF-ECT-20S-1/2	20	1/2	37	26.5	36	14	48	36
		HF-ECT-25S-3/4	25	3/4	42	30	42	16	54	46
		HF-ECT-30S-1	30	1	49	35.5	48	18	62	50

MALE STUD ELBOW

Thread NPT - Thread Metric Taper

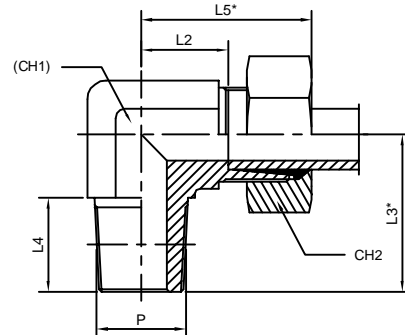
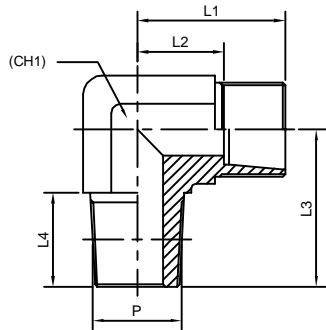

Series	W.P (Bar)	Part No.	Ø Tube	P NPT	L1	L2	L3*	L4	L5*	CH1	CH2
LL	100	HF-ECN-8LL-1/4	8	1/4	19.5	14	26	15	29	12	14
L	315	HF-ECN-6L-1/8	6	1/8	19	12	20	10	27	12	14
		HF-ECN-8L-1/4	8	1/4	21	14	26	15	29	12	17
		HF-ECN-10L-1/4	10	1/4	22	15	27	15	30	14	19
		HF-ECN-12L-3/8	12	3/8	24	17	28	15	32	17	22
		HF-ECN-12L-1/2	12	1/2	28	21	34	19.5	36	19	22
		HF-ECN-12L-3/4	12	3/4	35	28	40	20	44	27	22
		HF-ECN-15L-1/2	15	1/2	28	21	34	19.5	36	19	27
	160	HF-ECN-15L-3/4	15	3/4	28	21	42	20	36	27	27
		HF-ECN-18L-1/2	18	1/2	31	23	36	19.5	40	24	32
		HF-ECN-22L-3/4	22	3/4	35	27.5	42	20	44	27	36
		HF-ECN-28L-1	28	1	38	30.5	48	25	47	36	41
		HF-ECN-28L-1 1/4	28	1 1/4	42	34.5	57	25.5	56	41	41
		HF-ECN-35L-1	35	1	45	34	57	19	56	41	50
		HF-ECN-35L-1 1/4	35	1 1/4	45	34.5	57	25.5	56	41	50
S	630	HF-ECN-42L-1 1/4	42	1 1/4	51	40	61	26	63	50	60
		HF-ECN-42L-1 1/2	42	1 1/2	51	40	61	26	63	50	60
		HF-ECN-6S-1/4	6	1/4	23	16	26	15	31	12	17
		HF-ECN-8S-1/4	8	1/4	24	17	27	15	32	14	19
		HF-ECN-8S-3/8	8	3/8	24	17	27	15	32	17	19
		HF-ECN-8S-1/2	8	1/2	28	20.5	34	19.5	39	19	19
		HF-ECN-10S-1/4	10	1/4	25	17.5	28	15	34	19	22
	400	HF-ECN-10S-3/8	10	3/8	25	17.5	28	15	34	17	22
		HF-ECN-12S-1/4	12	1/4	29	21.5	28	15	37	19	24
		HF-ECN-12S-3/8	12	3/8	29	21.5	28	15	38	17	24
		HF-ECN-14S-1/2	14	1/2	30	22	34	19.5	40	19	27
		HF-ECN-16S-1/2	16	1/2	33	24	36	19.5	43	24	30
		HF-ECN-20S-3/4	20	3/4	37	26.5	42	20	48	27	36
		HF-ECN-25S-1	25	1	42	30	48	25	54	36	46
315	HF-ECN-30S-1 1/4	30	1 1/4	49	35.5	57	25.5	62	42	50	
	HF-ECN-38S-1 1/2	38	1 1/2	57	41	61	26	72	50	60	
L	315	HF-ECN-6L-1/4	6	1/4	21	14	24	10	29	12	14
		HF-ECN-8L-1/8	8	1/8	21	14	24	10	29	12	17
		HF-ECN-8L-3/8	8	3/8	23	16	28	15	31	17	17
		HF-ECN-8L-1/2	8	1/2	26	19	34	19.5	34	19	17
		HF-ECN-10L-1/8	10	1/8	22	15	24	10	30	14	19
		HF-ECN-10L-3/8	10	3/8	24	17	28	15	32	17	19
		HF-ECN-10L-1/2	10	1/2	27	20	34	19.5	35	19	19
		HF-ECN-12L-1/4	12	1/4	24	17	28	15	32	17	22
		HF-ECN-12L-1/2	12	1/2	27	20	34	19.5	35	19	22
		HF-ECN-15L-3/8	15	3/8	28	21	33	15	36	19	27
S	630	HF-ECN-18L-3/4	18	3/4	34	26.5	42	20	43	27	32
		HF-ECN-12S-1/2	12	1/2	28	20.5	34	19.5	39	19	24
	315	HF-ECN-14S-3/8	14	3/8	30	22	33	15	40	19	27
		HF-ECN-16S-3/8	16	3/8	33	24.5	37	15	43	24	30
		HF-ECN-20S-1/2	20	1/2	37	26.5	42	19.5	48	27	36
		HF-ECN-25S-3/4	25	3/4	42	30	46	20	54	36	46
		HF-ECN-30S-1	30	1	49	35.5	55	25	62	41	50

MALE STUD BRANCH TEE
Thread BSP Taper - Thread NPT

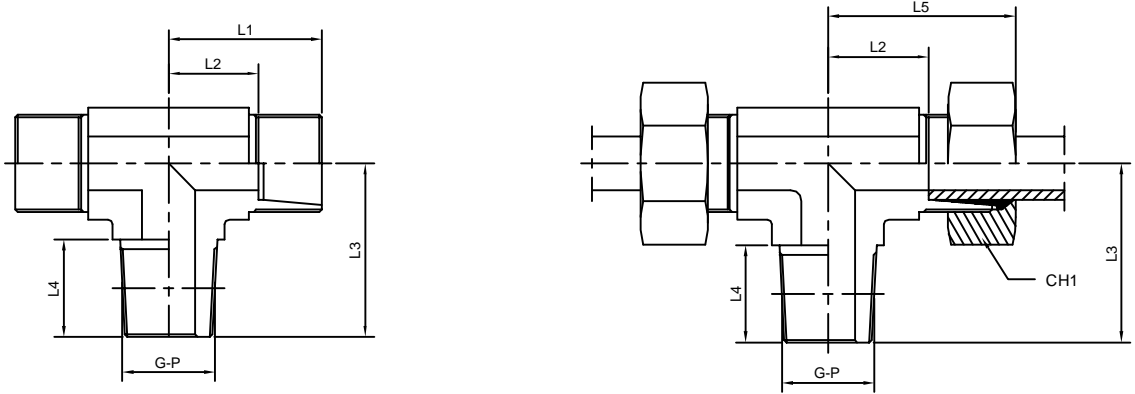

Series	W.P (Bar)	Part No.	Ø Tube	G	L1	L2	L3	L4	L5	CH1
LL	100	HF-TEB-4LL-1/8	4	1/8	15	11	21	8	21	10
		HF-TEB-6LL-1/8	6	1/8	15	9.5	21	8	21	12
		HF-TEB-8LL-1/8	8	1/8	17	11.5	23	8	23	14
L	315	HF-TEB-6L-1/8	6	1/8	19	12	27	8	27	14
		HF-TEB-8L-1/4	8	1/4	21	14	29	12	29	17
		HF-TEB-10L-1/4	10	1/4	22	15	30	12	30	19
		HF-TEB-12L-3/8	12	3/8	24	17	32	12	32	22
		HF-TEB-15L-1/2	15	1/2	28	21	36	14	36	27
		HF-TEB-18L-1/2	18	1/2	31	23.5	40	14	40	32
	160	HF-TEB-22L-3/4	22	3/4	35	27.5	44	16	44	36
		HF-TEB-28L-1	28	1	38	30.5	47	18	47	41
		HF-TEB-35L-1 1/4	35	1 1/4	45	34.5	56	20	56	50
S	630	HF-TEB-42L-1 1/2	42	1 1/2	51	40	63	22	63	60
		HF-TEB-6S-1/4	6	1/4	23	16	31	12	31	17
		HF-TEB-8S-1/4	8	1/4	24	17	32	12	32	19
		HF-TEB-10S-3/8	10	3/8	25	17.5	34	12	34	22
		HF-TEB-12S-3/8	12	3/8	29	21.5	38	12	38	24
		HF-TEB-14S-1/2	14	1/2	30	22	40	14	40	27
	400	HF-TEB-16S-1/2	16	1/2	33	24.5	43	14	43	30
		HF-TEB-20S-3/4	20	3/4	37	26.5	48	16	48	36
		HF-TEB-25S-1	25	1	42	30	54	18	54	46
		HF-TEB-30S-1 1/4	30	1 1/4	49	35.5	62	20	62	50
315	HF-TEB-38S-1 1/2	38	1 1/2	57	41	72	22	72	60	

Series	W.P (Bar)	Part No.	Ø Tube	P	L1	L2	L3	L4	L5	CH1
L	315	HF-TEB-6L-1/8	6	1/8	19	12	20	10	27	14
		HF-TEB-8L-1/4	8	1/4	21	14	26	15	29	17
		HF-TEB-10L-1/4	10	1/4	22	15	27	15	30	19
		HF-TEB-12L-3/8	12	3/8	24	17	28	15	32	22
		HF-TEB-15L-1/2	15	1/2	28	21	34	19.5	36	27
		HF-TEB-18L-1/2	18	1/2	31	23.5	36	19	40	32
	160	HF-TEB-22L-3/4	22	3/4	35	27.5	42	20	44	36
		HF-TEB-28L-1	28	1	38	30.5	48	25	47	41
		HF-TEB-35L-1 1/4	35	1 1/4	45	34.5	57	25.5	56	50
S	630	HF-TEB-42L-1 1/2	42	1 1/2	51	40	61	26	63	60
		HF-TEB-6S-1/4	6	1/4	23	16	26	15	31	17
		HF-TEB-8S-1/4	8	1/4	24	17	27	15	32	19
		HF-TEB-10S-3/8	10	3/8	25	17.5	28	15	34	22
		HF-TEB-12S-3/8	12	3/8	29	21.5	28	15	38	24
		HF-TEB-14S-1/2	14	1/2	30	22	34	19.5	40	27
	400	HF-TEB-16S-1/2	16	1/2	33	24.5	36	19	43	30
		HF-TEB-20S-3/4	20	3/4	37	26.5	42	20	48	36
		HF-TEB-25S-1	25	1	42	30	48	25	54	46
		HF-TEB-30S-1 1/4	30	1 1/4	49	35.5	57	25.5	62	50
315	HF-TEB-38S-1 1/2	38	1 1/2	57	41	61	26	72	60	

MALE STUD BARREL TEE
Thread BSP Taper - Thread NPT

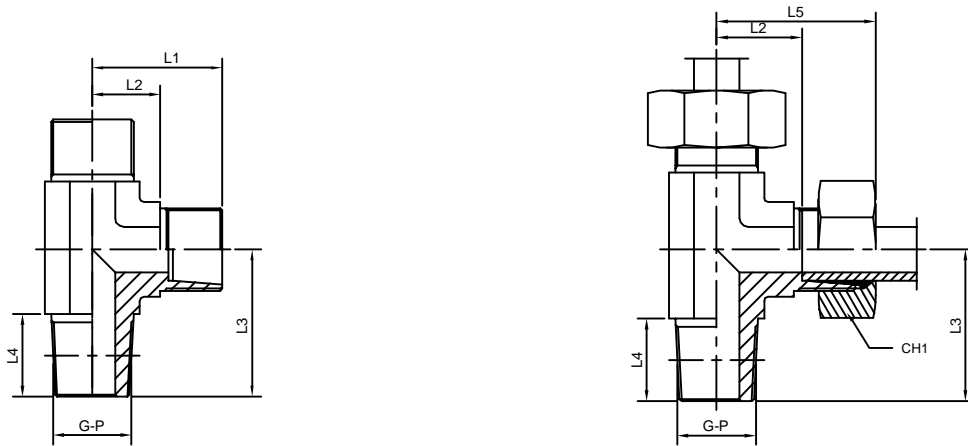

Series	W.P (Bar)	Part No.	Ø Tube	G	L1	L2	L3	L4	L5	CH1	
LL	100	HF-TER-4L-1/8	4	1/8	15	11	17	8	21	10	
		HF-TER-6L-1/8	6	1/8	15	9.5	17	8	21	12	
		HF-TER-8L-1/8	8	1/8	17	11.5	20	8	23	14	
L	315	HF-TER-6L-1/8	6	1/8	19	12	20	8	27	14	
		HF-TER-8L-1/4	8	1/4	21	14	26	12	29	17	
		HF-TER-10L-1/4	10	1/4	22	15	27	12	30	19	
		HF-TER-12L-3/8	12	3/8	24	17	28	12	32	22	
		HF-TER-15L-1/2	15	1/2	28	21	34	14	36	27	
		HF-TER-18L-1/2	18	1/2	31	23.5	36	14	40	32	
	160	HF-TER-22L-3/4	22	3/4	35	27.5	42	16	44	36	
		HF-TER-28L-1	28	1	38	30.5	48	18	47	41	
		HF-TER-35L-1 1/4	35	1 1/4	45	34.5	54	20	56	50	
S	630	HF-TER-42L-1 1/2	42	1 1/2	51	40	61	22	63	60	
		HF-TER-6S-1/4	6	1/4	23	16	26	12	31	17	
		HF-TER-8S-1/4	8	1/4	24	17	27	12	32	19	
		HF-TER-10L-3/8	10	3/8	25	17.5	28	12	34	22	
		HF-TER-12L-3/8	12	3/8	29	21.5	28	12	38	24	
		HF-TER-14L-1/2	14	1/2	30	22	32	14	40	27	
	400	HF-TER-16L-1/2	16	1/2	33	24.5	32	14	43	30	
		HF-TER-20L-3/4	20	3/4	37	26.5	42	16	48	36	
		HF-TER-25L-1	25	1	42	30	48	18	54	46	
		HF-TER-30L-1 1/4	30	1 1/4	49	35.5	54	20	62	50	
		315	HF-TER-38S-1 1/2	38	1 1/2	57	41	61	22	72	60

Series	W.P (Bar)	Part No.	Ø Tube	G	L1	L2	L3	L4	L5	CH1	
L	315	HF-TER-6L-1/8	6	1/8	19	12	20	10	27	14	
		HF-TER-8L-1/4	8	1/4	21	14	26	15	29	17	
		HF-TER-10L-1/4	10	1/4	22	15	27	15	30	19	
		HF-TER-12L-3/8	12	3/8	24	17	28	15	32	22	
		HF-TER-15L-1/2	15	1/2	28	21	34	19.5	36	27	
		HF-TER-18L-1/2	18	1/2	31	23.5	36	19	40	32	
	160	HF-TER-22L-3/4	22	3/4	35	27.5	42	20	44	36	
		HF-TER-28L-1	28	1	38	30.5	48	25	47	41	
		HF-TER-35L-1 1/4	35	1 1/4	45	34.5	57	25.5	56	50	
S	630	HF-TER-42L-1 1/2	42	1 1/2	51	40	61	26	63	60	
		HF-TER-6S-1/4	6	1/4	23	16	26	15	31	17	
		HF-TER-8S-1/4	8	1/4	24	17	27	15	32	19	
		HF-TER-10S-3/8	10	3/8	25	17.5	28	15	34	22	
		HF-TER-12S-3/8	12	3/8	29	21.5	28	15	38	24	
		HF-TER-14S-1/2	14	1/2	30	22	34	19.5	40	27	
	400	HF-TER-16S-1/2	16	1/2	33	24.5	36	19	43	30	
		HF-TER-20S-3/4	20	3/4	37	26.5	42	20	48	36	
		HF-TER-25S-1	25	1	42	30	48	25	54	46	
		HF-TER-30S-1 1/4	30	1 1/4	49	35.5	57	25.5	62	50	
		315	HF-TER-38S-1 1/2	38	1 1/2	57	41	61	26	72	60

STRAIGHT COUPLING

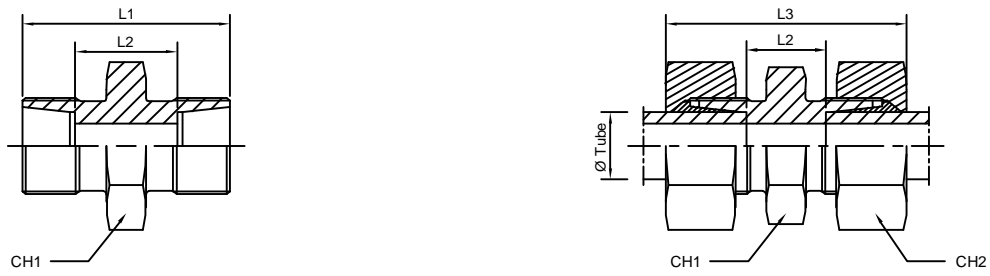

Series	W.P (Bar)	Part No.	Ø Tube	L1	L2	L3	CH1	CH2
LL	100	HF-SC-4LL	4	20	12	31	9	10
		HF-SC-6LL	6	20	9	32	11	12
		HF-SC-8LL	8	23	12	35	12	14
L	315	HF-SC-6L	6	24	10	39	12	14
		HF-SC-8L	8	25	11	40	14	17
		HF-SC-10L	10	27	13	42	17	19
		HF-SC-12L	12	28	14	43	19	22
		HF-SC-15L	15	30	16	46	24	27
		HF-SC-18L	18	31	16	48	27	32
	160	HF-SC-22L	22	35	20	52	32	36
		HF-SC-28L	28	36	21	54	41	41
		HF-SC-35L	35	41	20	63	46	50
S	630	HF-SC-6S	6	30	16	45	14	17
		HF-SC-8S	8	32	18	47	17	19
		HF-SC-10S	10	32	17	49	19	22
		HF-SC-12S	12	34	19	51	22	24
		HF-SC-14S	14	38	22	57	24	27
	400	HF-SC-16S	16	38	21	57	27	30
		HF-SC-20S	20	44	23	66	32	36
		HF-SC-25S	25	50	26	74	41	46
		HF-SC-30S	30	54	27	80	46	50
		HF-SC-38S	38	61	29	90	55	60

BULKHEAD CONNECTION

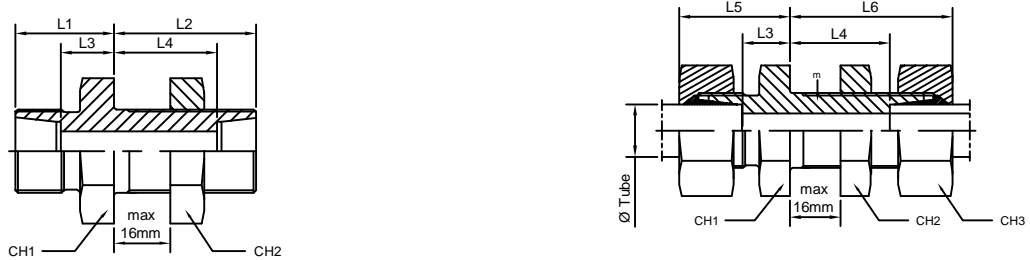

Series	W.P (Bar)	Part No.	Ø Tube	m	L1	L2	L3	L4	L5	L6	CH1	CH2	CH3
L	315	HF-BHC-6L-M12X1.5	6	12X1.5	14	34	7	27	22	42	17	17	14
		HF-BHC-8L-M14X1.5	8	14X1.5	15	34	8	27	23	42	19	19	17
		HF-BHC-10L-M16X1.5	10	16X1.5	17	35	10	28	25	43	22	22	19
		HF-BHC-12L-M18X1.5	12	18X1.5	17	36	10	29	25	44	24	24	22
		HF-BHC-15L-M22X1.5	15	22X1.5	19	38	12	31	27	46	27	30	27
	160	HF-BHC-18L-M26X1.5	18	26X1.5	21	40	13.5	32.5	30	49	32	36	32
		HF-BHC-22L-M30X1.5	22	30X2	24	42	16.5	34.5	33	51	36	41	36
		HF-BHC-28L-M36X2	28	36X2	26	43	18.5	35.5	35	52	41	46	41
		HF-BHC-35L-M45X2	35	45X2	29	47	18.5	36.5	40	58	50	55	50
		HF-BHC-42L-M52X2	42	52X2	30	47	19	36	42	59	60	65	60
S	630	HF-BHC-6S-M14X1.5	6	14X1.5	19	36	12	29	27	44	19	19	17
		HF-BHC-8S-M16X1.5	8	16X1.5	20	36	13	29	28	44	22	22	19
		HF-BHC-10S-M18X1.5	10	18X1.5	22	37	14.5	29.5	31	46	24	24	22
		HF-BHC-12S-M20X1.5	12	20X1.5	22	38	14.5	30.5	31	47	27	27	24
		HF-BHC-14S-M22X1.5	14	22X1.5	25	40	17	32	35	50	30	30	27
	400	HF-BHC-16S-M24X1.5	16	24X1.5	25	40	16.5	31.5	35	50	32	32	30
		HF-BHC-20S-M30X2	20	30X2	28	44	17.5	33.5	39	55	41	41	36
		HF-BHC-25S-M36X2	25	36X2	31	47	20	35	44	59	46	46	46
		HF-BHC-30S-M42X2	30	42X2	35	51	21.5	37.5	48	64	50	50	50
		HF-BHC-38S-M52X2	38	52X2	38	53	22	37	53	68	65	65	60

BULKHEAD ELBOW

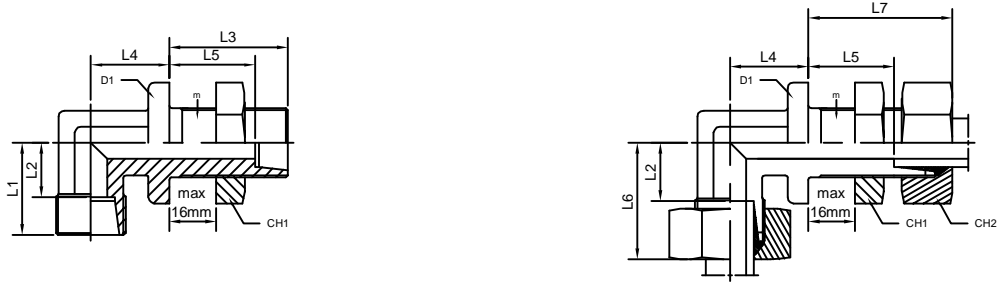

Series	W.P (Bar)	Part No.	Ø Tube	m	L1	L2	L3	L4	L5	L6	L7	D1	CH1	CH2	CH3
L	315	HF-BHE-6L-M12X1.5	6	12X1.5	19	12	34	14	27	19	42	17	12	17	14
		HF-BHE-8L-M14X1.5	8	14X1.5	21	14	34	17	27	21	42	19	12	19	17
		HF-BHE-10L-M16X1.5	10	16X1.5	22	15	35	18	28	22	43	22	14	22	19
		HF-BHE-12L-M18X1.5	12	18X1.5	24	17	36	20	29	24	44	24	17	24	22
		HF-BHE-15L-M22X1.5	15	22X1.5	28	21	38	23	31	28	46	27	19	30	27
	HF-BHE-18L-M26X1.5	18	26X1.5	31	23.5	40	24	32.5	31	49	32	24	36	32	
	HF-BHE-22L-M30X2	22	30X2	35	27.5	42	30	34.5	35	51	36	27	41	36	
	HF-BHE-28L-M36X2	28	36X2	38	30.5	43	34	35.5	38	52	42	36	46	41	
S	630	HF-BHE-6S-M14X1.5	6	14X1.5	23	16	36	17	29	23	44	19	12	19	17
		HF-BHE-8S-M16X1.5	8	16X1.5	24	17	36	18	29	24	44	22	14	22	19
		HF-BHE-10S-M18X1.5	10	18X1.5	25	17.5	37	20	29.5	25	46	24	17	24	22
		HF-BHE-12S-M20X1.5	12	20X1.5	2	21.5	38	21	30.5	29	47	27	17	27	24
		HF-BHE-14S-M22X1.5	14	22X1.5	30	22	40	23	32	30	50	27	19	30	27
		HF-BHE-16S-M24X1.5	16	24X1.5	33	24.5	40	24	31.5	33	50	30	24	32	30
	400	HF-BHE-20S-M30X2	20	30X2	37	26.5	44	30	33.5	37	55	36	27	41	36
		HF-BHE-25S-M36X2	25	36X2	42	30	47	34	35	42	59	42	36	46	46
		HF-BHE-30S-M42X2	30	42X2	49	35.5	51	39	37.5	49	64	50	41	50	50
		HF-BHE-38S-M52X2	38	52X2	57	41	53	43	37	57	68	60	50	65	60

EQUAL ELBOW



Series	W.P (Bar)	Part No.	Ø Tube	L1	L2	L3	CH1	CH2
LL	100	HF-EE-4LL	4	15	11	21	9	10
		HF-EE-6LL	6	15	9.5	21	9	12
		HF-EE-8LL	8	17	11.5	23	12	14
L	315	HF-EE-6L	6	19	12	27	12	14
		HF-EE-8L	8	21	14	29	12	17
		HF-EE-10L	10	22	15	30	14	19
		HF-EE-12L	12	24	17	32	17	22
	160	HF-EE-15L	15	28	21	36	19	27
		HF-EE-18L	18	31	23.5	40	24	32
		HF-EE-22L	22	35	27.5	44	27	36
		HF-EE-28L	28	38	30.5	47	36	41
S	630	HF-EE-35L	35	45	34.5	56	41	50
		HF-EE-42L	42	51	40	63	50	60
		HF-EE-6S	6	23	16	31	12	17
		HF-EE-8S	8	24	17	32	14	19
		HF-EE-10S	10	25	17.5	34	17	22
		HF-EE-12S	12	2	21.5	38	17	24
	400	HF-EE-14S	14	30	22	40	19	27
		HF-EE-1S	16	33	24.5	43	24	30
		HF-EE-20S	20	37	26.5	48	27	36
		HF-EE-25S	25	42	30	54	36	46
		HF-EE-30S	30	49	35.5	61	41	50
		HF-EE-38S	38	57	41	72	50	60

EQUAL TEE

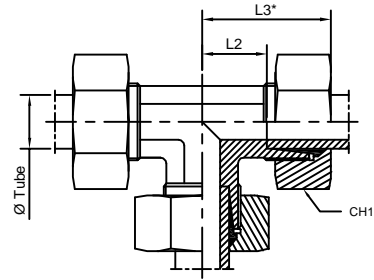
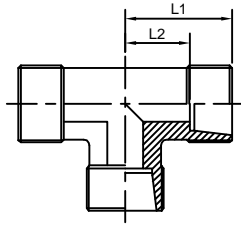

Series	W.P (Bar)	Part No.	Ø Tube	L1	L2	L3*	CH1	
LL	100	HF-ET-4LL	4	15	11	21	10	
		HF-ET-6LL	6	15	9.5	21	12	
		HF-ET-8LL	8	17	11.5	23	14	
L	315	HF-ET-6L	6	19	12	27	14	
		HF-ET-8L	8	21	14	29	17	
		HF-ET-10L	10	22	15	30	19	
		HF-ET-12L	12	24	17	32	22	
		HF-ET-15L	15	28	21	36	27	
		HF-ET-18L	18	31	23.5	40	32	
	160	HF-ET-22L	22	35	27.5	44	36	
		HF-ET-28L	28	38	30.5	47	41	
		HF-ET-35L	35	45	34.5	56	50	
S	630	HF-ET-42L	42	51	40	63	60	
		HF-ET-6S	6	23	16	31	17	
		HF-ET-8S	8	24	17	32	19	
		HF-ET-10S	10	25	17.5	34	22	
		HF-ET-12S	12	29	21.5	38	24	
		HF-ET-14S	14	30	22	40	27	
	400	HF-ET-16S	16	33	24.5	43	30	
		HF-ET-20S	20	37	26.5	48	36	
		HF-ET-25S	25	42	30	54	46	
		HF-ET-30S	30	49	35.5	62	50	
		315	HF-ET-38S	38	57	41	72	60

EQUAL CROSS

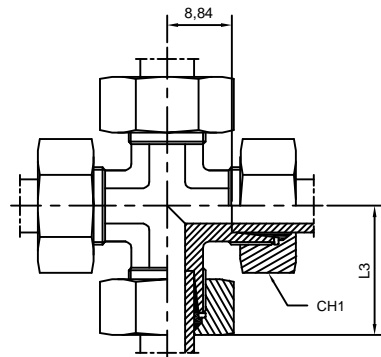
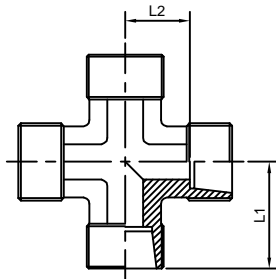

Series	W.P (Bar)	Part No.	Ø Tube	L1	L2	L3	CH1	
LL	100	HF-EC-4LL	4	15	11	21	10	
		HF-EC-6LL	6	15	9.5	21	12	
		HF-EC-8LL	8	17	11.5	23	14	
L	315	HF-EC-6L	6	19	12	27	14	
		HF-EC-8L	8	21	14	29	17	
		HF-EC-10L	10	22	15	30	19	
		HF-EC-12L	12	24	17	32	22	
		HF-EC-15L	15	28	21	36	27	
		HF-EC-18L	18	31	23.5	40	32	
	160	HF-EC-22L	22	35	27.5	44	36	
		HF-EC-28L	28	38	30.5	47	41	
		HF-EC-35L	35	45	34.5	56	50	
S	630	HF-EC-42L	42	51	40	63	60	
		HF-EC-6S	6	23	16	31	17	
		HF-EC-8S	8	24	17	32	19	
		HF-EC-10S	10	25	17.5	34	22	
		HF-EC-12S	12	29	21.5	38	24	
		HF-EC-14S	14	30	22	40	27	
	400	HF-EC-16S	16	33	24.5	43	30	
		HF-EC-20S	20	37	26.5	48	36	
		HF-EC-25S	25	42	30	54	46	
		HF-EC-30S	30	49	35.5	62	50	
		315	HF-EC-38S	38	57	41	72	60

STRAIGHT REDUCING COUPLING

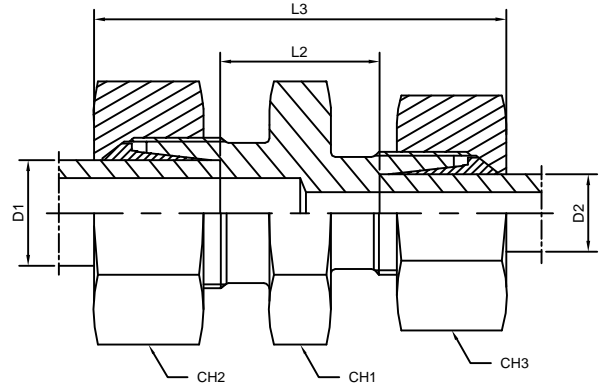
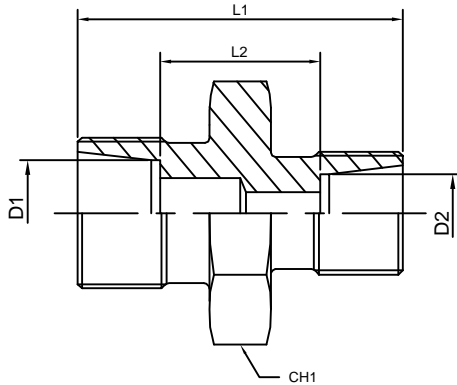

Series	W.P (Bar)	Part No.	Ø Tube		L1	L2	L3	CH1	CH2	CH3	
			D1	D2							
L	315	HF-USC-8L/6L	8	6	25	11	40.5	14	17	14	
		HF-USC-10L/6L	10	6	26	12	41.5	17	19	14	
		HF-USC-10L/8L	10	8	26	12	42	17	19	17	
		HF-USC-12L/6L	12	6	27	13	42	19	22	14	
		HF-USC-12L/8L	12	8	27	13	42.5	19	22	17	
		HF-USC-12L/10L	12	10	28	14	43.5	19	22	19	
		HF-USC-15L/10L	15	10	29	15	45	24	27	19	
		HF-USC-15L/12L	15	12	29	15	44.5	24	27	22	
		HF-USC-18L/10L	18	10	30	15.5	47	27	32	19	
	HF-USC-18L/12L	18	12	30	15.5	46.5	27	32	22		
	HF-USC-18L/15L	18	15	31	16.5	48	27	32	27		
	160	HF-USC-22L/12L	22	12	32	17.5	48.5	32	36	22	
		HF-USC-22L/15L	22	15	33	18.5	50	32	36	27	
		HF-USC-22L/18L	22	18	33	18	51	32	36	32	
		HF-USC-28L/18L	28	18	34	19	52	41	41	32	
		HF-USC-28L/22L	28	22	36	21	54	41	41	36	
HF-USC-35L/22L		35	22	39	21	59	46	50	36		
HF-USC-35L/28L		35	28	39	21	59	46	50	41		
S	630	HF-USC-8S/6S	8	6	32	18	48	17	19	17	
		HF-USC-10S/6S	10	6	32	17.5	48.5	19	22	17	
		HF-USC-10S/8S	10	8	32	17.5	48.5	19	22	19	
		HF-USC-12S/6S	12	6	34	19.5	50.5	22	24	17	
		HF-USC-12S/8S	12	8	34	19.5	50.5	22	24	19	
		HF-USC-12S/10S	12	10	34	19	51	22	24	22	
		HF-USC-14S/10S	14	10	36	20.5	54.5	24	27	22	
		HF-USC-14S/12S	14	12	36	20.5	54.5	24	27	24	
	400	HF-USC-16S/12S	16	12	36	20	54.5	27	30	24	
		HF-USC-16S/14S	16	14	38	21.5	58	27	30	27	
		HF-USC-20S/10S	20	10	40	22	59.5	32	36	22	
		HF-USC-20S/12S	20	12	40	22	59.5	32	36	24	
		HF-USC-20S/16S	20	16	42	23	63	32	36	30	
		HF-USC-25S/16S	25	16	46	25.5	68	41	46	30	
		HF-USC-25S/20S	25	20	48	25.5	71	41	46	36	
		HF-USC-30S/20S	30	20	50	26	74	46	50	36	
		HF-USC-30S/25S	30	25	52	26.5	77	46	50	46	
		315	HF-USC-38S/30S	38	30	59	29.5	87	55	60	50

BULKHEAD CONNECTION WITH ELASTOMER SEAL

Thread BSP Parallel

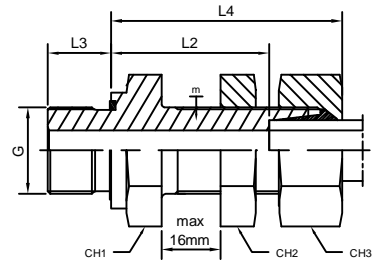
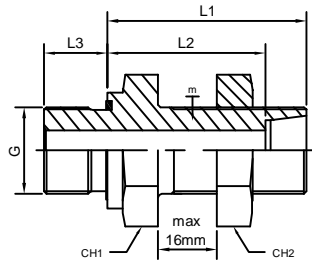

Series	W.P (Bar)	Part No.	Ø Tube	m	G	L1	L2	L3	L4	CH1	CH2	CH3
L	315	HF-BHCR-6L-1/8	6	12X1.5	1/8	39.5	32.5	8	47.5	17	17	14
		HF-BHCR-8L-1/4	8	14X1.5	1/4	41	34	12	49	19	19	17
		HF-BHCR-10L-1/4	10	16X1.5	1/4	43	36	12	51	22	22	19
		HF-BHCR-12L-3/8	12	18X1.5	3/8	44.5	37.5	12	52.5	24	24	22
		HF-BHCR-15L-1/2	15	22X1.5	1/2	48	41	14	56	27	30	27
	160	HF-BHCR-18L-1/2	18	26X1.5	1/2	52	44.5	14	61	32	36	32
		HF-BHCR-22L-3/4	22	30X2	3/4	55	47.5	16	64	36	41	36
		HF-BHCR-28L-1	28	36X2	1	58	50.5	18	67	41	46	41
		HF-BHCR-35L-1 1/4	35	45X2	1 1/4	63	52.5	20	74	50	55	50
		HF-BHCR-42L-1 1/2	42	52X2	1 1/2	64	53	22	76	60	65	60
S	630	HF-BHCR-6S-1/4	6	14X1.5	1/4	45	38	12	53	19	19	17
		HF-BHCR-8S-1/4	8	16X1.5	1/4	46	39	12	54	22	22	19
		HF-BHCR-10S-3/8	10	18X1.5	3/8	49	41.5	12	58	24	24	22
		HF-BHCR-12S-3/8	12	20X1.5	3/8	50	42.5	12	59	27	27	24
		HF-BHCR-14S-1/2	14	22X1.5	1/2	54	46	14	64	30	30	27
	400	HF-BHCR-16S-1/2	16	24X1.5	1/2	54	45.5	14	64	32	32	30
		HF-BHCR-20S-3/4	20	30X2	3/4	59	48.5	16	72	41	41	36
		HF-BHCR-25S-1	25	36X2	1	64	52	18	76	46	46	46
		HF-BHCR-30S-1 1/4	30	42X2	1 1/4	69	55.5	20	82	50	50	50
		HF-BHCR-38S-1 1/2	38	52X2	1 1/2	72	56	22	87	65	65	60

WELDING BOSS

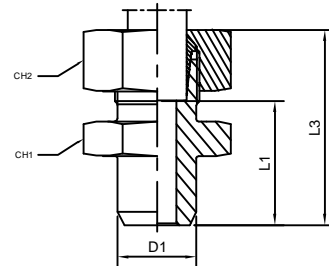
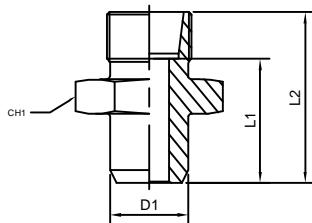

Series	W.P (Bar)	Part No.	Ø Tube	D1	L1	L2	L3	CH1	CH2
L	315	HF-WC-6L	6	10	14	21	29	12	14
		HF-WC-8L	8	12	16	23	31	14	17
		HF-WC-10L	10	14	18	25	33	17	19
		HF-WC-12L	12	16	18	25	33	19	22
		HF-WC-15L	15	19	22	29	37	22	27
	160	HF-WC-18L	18	22	23.5	31	40	27	32
		HF-WC-22L	22	27	28.5	36	45	32	36
		HF-WC-28L	28	32	30.5	38	47	41	41
		HF-WC-35L	35	40	32.5	43	54	46	50
		HF-WC-42L	42	46	35	46	58	55	60
S	630	HF-WC-6S	6	11	19	26	34	14	17
		HF-WC-8S	8	13	21	28	36	17	19
		HF-WC-10S	10	15	22.5	30	39	19	22
		HF-WC-12S	12	17	24.5	32	41	22	24
		HF-WC-14S	14	19	27	35	45	24	27
	400	HF-WC-16S	16	21	26.5	35	45	27	30
		HF-WC-20S	20	26	29.5	40	51	32	36
		HF-WC-25S	25	31	32	44	56	41	46
		HF-WC-30S	30	36	35.5	49	62	46	50
		HF-WC-38S	38	44	38	54	69	55	60

WELDING BULKHEAD CONNECTION

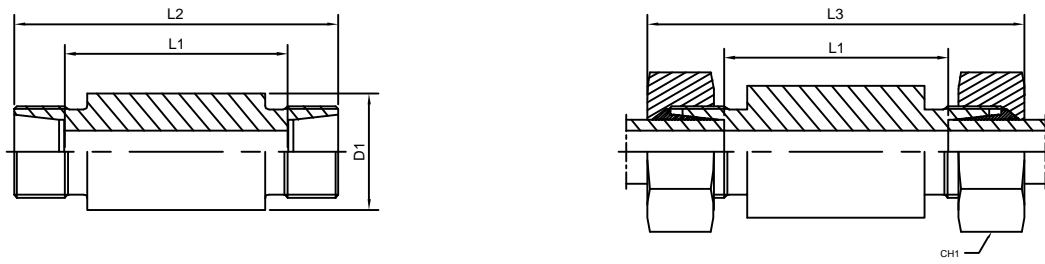

Series	W.P (Bar)	Part No.	Ø Tube	D1	L1	L2	L3	CH1
L	315	HF-WBC-6L	6	18	56	70	85	14
		HF-WBC-8L	8	20	56	70	85	17
		HF-WBC-10L	10	22	58	72	87	19
		HF-WBC-12L	12	25	58	72	87	22
		HF-WBC-15L	15	28	70	84	100	27
	HF-WBC-18L	18	32	69	84	101	32	
	160	HF-WBC-22L	22	36	73	88	105	36
		HF-WBC-28L	28	40	73	88	106	41
HF-WBC-35L		35	50	71	92	114	50	
S	630	HF-WBC-42L	42	60	70	92	115	60
		HF-WBC-6S	6	20	60	74	89	17
		HF-WBC-8S	8	22	60	74	89	19
		HF-WBC-10S	10	25	59	74	91	22
		HF-WBC-12S	12	28	59	74	91	24
	400	HF-WBC-14S	14	30	72	88	107	27
		HF-WBC-16S	16	35	71	88	107	30
		HF-WBC-20S	20	38	71	92	114	36
		HF-WBC-25S	25	45	72	96	120	46
		HF-WBC-30S	30	50	73	100	126	50
315	HF-WBC-38S	38	60	72	104	133	60	

WELDING NIPPLE WITH O-RING

Delivered separately (unassembled)

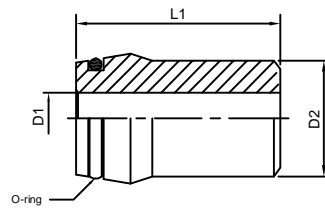

Series	W.P (Bar)	Part No.	Spessore	Ø Tube	D1	D2	L1
L/S	630	HF-WN-6X1.75	6X1.75	6	2.5	6	31
		HF-WN-8X2	8X2	8	4	8	31
	315	HF-WN-10X1.5	10X1.5	10	7	10	32.5
		HF-WN-10X2	10X2	10	6	10	32.5
	400	HF-WN-12X1.5	12X1.5	12	9	12	32.5
		HF-WN-12X2	12X2	12	8	12	32.5
L	315	HF-WN-12X2.5	12X2.5	12	7	12	32.5
		HF-WN-15X2.5	15X2.5	15	10	15	34
	160	HF-WN-18X2.5	18X2.5	18	13	18	35
		HF-WN-22X2.5	22X2.5	22	17	22	38
		HF-WN-28X2.5	28X2.5	28	23	28	41.5
		HF-WN-35X3	35X3	35	29	35	47.5
S	400	HF-WN-42X3	42X3	42	36	42	47.5
		HF-WN-14X3	14X3	14	8	14	38.5
	250	HF-WN-16X2	16X2	16	12	16	39
		HF-WN-16X2.5	16X2.5	16	11	16	39
	315	HF-WN-16X3	16X3	16	10	16	39
		HF-WN-20X2.5	20X2.5	20	15	20	45
	250	HF-WN-20X3	20X3	20	14	20	45
		HF-WN-20X4	20X4	20	12	20	45
	315	HF-WN-25X3	25X3	25	19	25	49.5
		HF-WN-25X4	25X4	25	17	25	49.5
	160	HF-WN-25X5	25X5	25	15	25	49.5
		HF-WN-30X3	30X3	30	24	30	52
	250	HF-WN-30X4	30X4	30	22	30	52
		HF-WN-30X5	30X5	30	20	30	52
	315	HF-WN-30X6	30X6	30	18	30	52
		HF-WN-38X3	38X3	38	32	38	56.5
	160	HF-WN-38X5	38X5	38	28	38	56.5
		HF-WN-38X6	38X6	38	26	38	56.5
250	HF-WN-38X8	38X8	38	22	38	56.5	
	HF-WN-38X8	38X8	38	22	38	56.5	

WELDING ELBOW

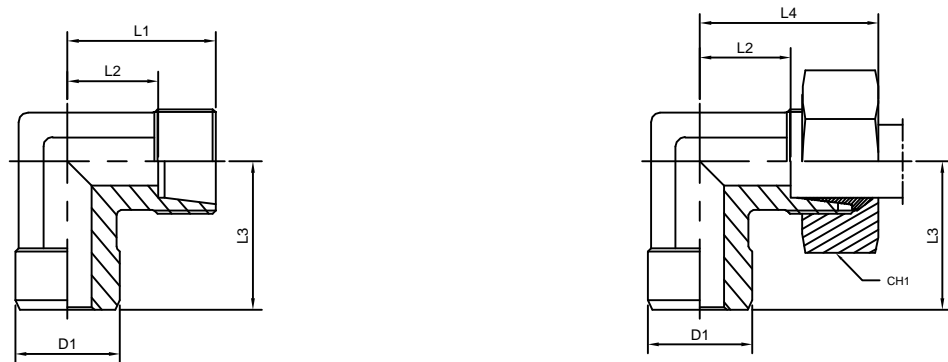

Series	W.P (Bar)	Part No.	Ø Tube	D1	L1	L2	L3	L4	CH1
L	315	HF-WE-6L	6	10	19	12	19	27	14
		HF-WE-8L	8	12	21	14	21	29	17
		HF-WE-10L	10	14	22	15	22	30	19
		HF-WE-12L	12	16	24	17	24	32	22
		HF-WE-15L	15	19	28	21	28	36	27
	160	HF-WE-18L	18	22	31	23.5	31	40	32
		HF-WE-22L	22	27	35	27.5	35	44	36
		HF-WE-28L	28	32	38	30.5	38	47	41
		HF-WE-35L	35	40	45	34.5	45	56	50
		HF-WE-42L	42	46	51	40	51	63	60
S	630	HF-WE-6S	6	11	23	16	23	31	17
		HF-WE-8S	8	13	24	17	24	32	19
		HF-WE-10S	10	15	25	17.5	25	34	22
		HF-WE-12S	12	17	29	21.5	29	38	24
		HF-WE-14S	14	19	30	22	30	40	27
	400	HF-WE-16S	16	21	33	24.5	33	43	30
		HF-WE-20S	20	26	37	26.5	37	48	36
		HF-WE-25S	25	31	42	30	42	54	46
		HF-WE-30S	30	36	49	35.5	49	62	50
		HF-WE-38S	38	44	57	41	57	72	60

GAUGE COUPLING

Thread BSP Parallel

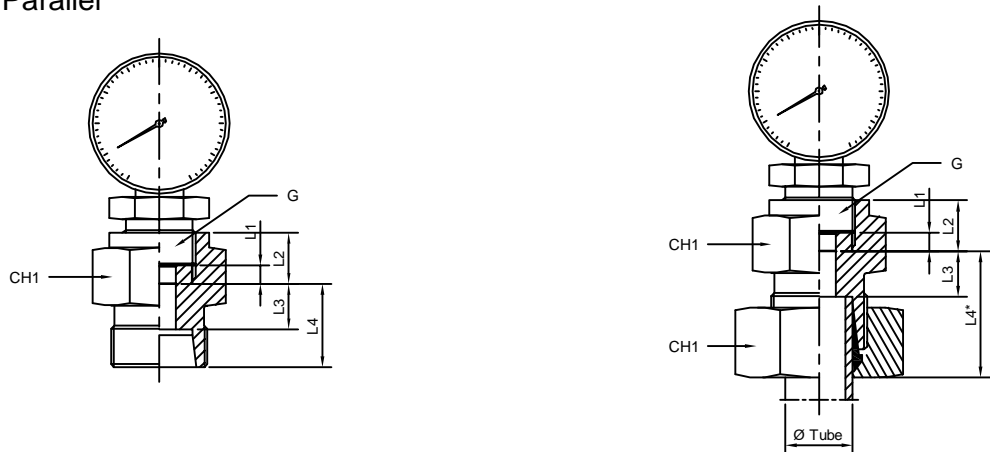

Series	W.P (Bar)	Part No.	Ø Tube	G	L1	L2	L3	L4*	CH1	CH2
L	315	HF-MC-6L-1/4	6	1/4	4.5	14.5	7.5	14.5	19	14
		HF-MC-8L-1/4	8	1/4	4.5	14.5	7.5	14.5	19	17
		HF-MC-10L-1/4	10	1/4	4.5	14.5	8.5	15.5	19	19
		HF-MC-12L-1/4	12	1/4	4.5	14.5	8.5	15.5	19	22
S	630	HF-MC-6S-1/2	6	1/2	5	20	11	18	30	17
		HF-MC-8S-1/2	8	1/2	5	20	11	18	30	19
		HF-MC-10S-1/2	10	1/2	5	20	10.5	18	30	22
		HF-MC-12S-1/2	12	1/2	5	20	10.5	18	30	24

ADJUSTABLE DIN MALE STUD ELBOW WITH O-RING AND WASHER

Thread BSP Parallel - Thread Metric Parallel



Series	W.P (Bar)	Part No.	Ø Tube	G	L1	L2	L3	L4	CH1	CH2
L	315	HF-AE-6L-1/8	6	1/8	19	12	26	27	14	14
		HF-AE-8L-1/4	8	1/4	21	14	32	29	19	17
		HF-AE-10L-1/4	10	1/4	22	15	32	30	19	19
		HF-AE-12L-3/8	12	3/8	24	17	37	32	22	22
		HF-AE-15L-1/2	15	1/2	28	21	44	36	27	27
	HF-AE-18L-1/2	18	1/2	31	23.5	47	40	27	32	
	HF-AE-22L-3/4	22	3/4	35	27.5	51	44	36	36	
	HF-AE-28L-1	28	1	38	30.5	53	47	41	41	
S	630	HF-AE-35L-1 1/4	35	1 1/4	45	34.5	59	56	50	50
		HF-AE-42L-1 1/2	42	1 1/2	51	40	64	63	55	60
		HF-AE-6S-1/4	6	1/4	23	16	32	31	19	17
		HF-AE-8S-1/4	8	1/4	24	17	32	32	19	19
	400	HF-AE-10S-3/8	10	3/8	25	17.5	37	34	22	22
		HF-AE-12S-3/8	12	3/8	29	21.5	37	38	22	24
		HF-AE-14S-1/2	14	1/2	30	22	44	40	27	27
		HF-AE-16S-1/2	16	1/2	33	24.5	47	43	27	30
HF-AE-20S-3/4		20	3/4	37	26.5	51	48	36	36	
HF-AE-25S-1		25	1	42	30	53	54	41	46	
HF-AE-30S-1 1/4		30	1 1/4	49	35.5	59	62	50	50	
HF-AE-38S-1 1/2		38	1 1/2	57	41	64	72	65	60	

Series	W.P (Bar)	Part No.	Ø Tube	M	L1	L2	L3	L4	CH1	CH2
L	315	HF-AE-6L-M10X1	6	10X1	19	12	26	27	14	14
		HF-AE-8L-M12X1.5	8	12X1.5	21	14	32	29	19	17
		HF-AE-10L-M14X1.5	10	14X1.5	22	15	32	30	19	19
		HF-AE-12L-M16X1.5	12	16X1.5	24	17	37	32	22	22
		HF-AE-15L-M18X1.5	15	18X1.5	28	21	44	36	27	27
	HF-AE-18L-M22X1.5	18	22X1.5	31	23.5	47	40	27	32	
	HF-AE-22L-M27X2	22	27X2	35	27.5	51	44	36	36	
	HF-AE-28L-M33X2	28	33X2	38	30.5	53	47	41	41	
S	630	HF-AE-35L-M42X2	35	42X2	45	34.5	59	56	50	50
		HF-AE-42L-M48X2	42	48X2	51	40	64	63	55	60
		HF-AE-6S-M12X1.5	6	12X1.5	23	16	32	31	19	17
		HF-AE-8S-M14X1.5	8	14X1.5	24	17	32	32	19	19
	400	HF-AE-10S-M16X1.5	10	16X1.5	25	17.5	37	34	22	22
		HF-AE-12S-M18X1.5	12	18X1.5	29	21.5	37	38	22	24
		HF-AE-14S-M20X1.5	14	20X1.5	30	22	44	40	27	27
		HF-AE-16S-M22X1.5	16	22X1.5	33	24.5	47	43	27	30
HF-AE-20S-M27X2		20	27X2	37	26.5	51	48	36	36	
HF-AE-25S-M33X2		25	33X2	42	30	53	54	41	46	
HF-AE-30S-M42X2		30	42X2	49	35.5	59	62	50	50	
HF-AE-38S-M48X2		38	48X2	57	41	64	72	65	60	

ADJUSTABLE DIN MALE STUD ELBOW WITH O-RING

Thread UNF/UN-2A

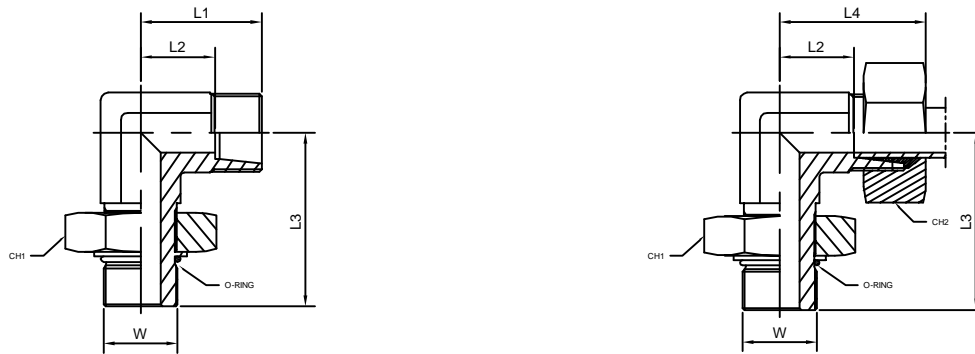

Series	W.P (Bar)	Part No.	Ø Tube	W	L1	L2	L3	L4	CH1	CH2
L	315	HF-AEU-6L-7/16	6	7/16-20	19	12	27	27	14	14
		HF-AEU-8L-7/16	8	7/16-20	21	14	28	29	14	17
		HF-AEU-10L-9/16	10	9/16-18	22	15	32	30	17	19
		HF-AEU-12L-3/4	12	3/4-16	24	17	37	32	22	22
	160	HF-AEU-15L-7/8	15	7/8-14	28	21	43	36	27	27
		HF-AEU-18L-7/8	18	7/8-14	31	23.5	47	40	27	32
		HF-AEU-22L-1 1/16	22	1 1/16-12	35	27.5	49.5	44	32	36
		HF-AEU-28L-1 5/16	28	1 5/16-12	38	30.5	52	47	41	41
S	630	HF-AEU-6S-7/16	6	7/16-20	23	16	29	31	14	17
		HF-AEU-8S-9/16	8	9/16-18	24	17	33	32	17	19
		HF-AEU-10S-9/16	10	9/16-18	25	17.5	37.5	34	17	22
		HF-AEU-12S-3/4	12	3/4-16	29	21.5	38	38	22	24
	400	HF-AEU-14S-7/8	14	7/8-14	30	22	44	40	27	27
		HF-AEU-16S-7/8	16	7/8-14	33	24.5	48	43	27	30
		HF-AEU-20S-1 1/16	20	1 1/16-12	37	26.5	51	48	32	36
		HF-AEU-25S-1 5/16	25	1 5/16-12	42	30	53	54	41	46
	315	HF-AEU-30S-1 5/8	30	1 5/8-12	49	35.5	59	62	50	50
		HF-AEU-38S-1 7/8	38	1 7/8-12	57	41	62	72	65	60

ADJUSTABLE DIN MALE 45° STUD ELBOW WITH O-RING AND WASHER

Thread BSP Parallel



Series	W.P (Bar)	Part No.	Ø Tube	G	L1	L2	L3	L4	CH1	CH2	
L	315	HF-AE45B-6L-1/8	6	1/8	16	9	26	24	14	14	
		HF-AE45B-8L-1/4	8	1/4	19	12	29	27	19	17	
		HF-AE45B-10L-1/4	10	1/4	19	12	29	27	19	19	
		HF-AE45B-12L-3/8	12	3/8	21	14	33	29	22	22	
	160	HF-AE45B-15L-1/2	15	1/2	24	17	38.5	32	27	27	
		HF-AE45B-18L-1/2	18	1/2	24.5	17	38.5	33.5	27	32	
		HF-AE45B-22L-3/4	22	3/4	26	18.5	44	35	36	36	
		HF-AE45B-28L-1	28	1	30.5	23	47	39.5	41	41	
S	630	HF-AE45B-35L-1 1/4	35	1 1/4	33	22.5	48	44	50	50	
		HF-AE45B-42L-1 1/2	42	1 1/2	37	26	48	49	55	60	
		HF-AE45B-6S-1/4	6	1/4	16	9	29	24	19	17	
		HF-AE45B-8S-1/4	8	1/4	19	12	29	27	19	19	
	400	HF-AE45B-10S-3/8	10	3/8	20	12.5	33	29	22	22	
		HF-AE45B-12S-3/8	12	3/8	21	13.5	33	30	22	24	
		HF-AE45B-14S-1/2	14	1/2	24	16	38.5	34	27	27	
		HF-AE45B-16S-1/2	16	1/2	24	15.5	38.5	34	27	30	
	315	HF-AE45B-20S-3/4	20	3/4	26.5	16	44	37.5	36	36	
		HF-AE45B-25S-1	25	1	31	19	47	43	41	46	
			HF-AE45B-30S-1 1/4	30	1 1/4	35	21.5	48	48	50	50
			HF-AE45B-38S-1 1/2	38	1 1/2	39	23	48	54	55	60

ADJUSTABLE DIN MALE 45° STUD ELBOW WITH O-RING AND WASHER

Thread Metric Parallel



Series	W.P (Bar)	Part No.	Ø Tube	M	L1	L2	L3	L4	CH1	CH2
L	315	HF-AE45M-6L-M10X1	6	10X1	16	9	27	24	14	14
		HF-AE45M-8L-M12X1.5	8	12X1.5	19	12	27	27	17	17
		HF-AE45M-10L-M14X1.5	10	14X1.5	19	12	28	27	19	19
		HF-AE45M-12L-M16X1.5	12	16X1.5	21	14	33	29	22	22
		HF-AE45M-15L-M18X1.5	15	18X1.5	24	17	36	32	24	27
	160	HF-AE45M-18L-M22X1.5	18	22X1.5	24.5	17	38	33.5	27	32
		HF-AE45M-22L-M27X2	22	27X2	26	18.5	46	35	32	36
		HF-AE45M-28L-M33X2	28	33X2	30.5	23	46	39.5	41	41
		HF-AE45M-35L-M42X2	35	42X2	33	22.5	48	44	50	50
		HF-AE45M-42L-M48X2	42	48X2	37	26	50	49	55	60
S	630	HF-AE45M-6S-M12X1.5	6	12X1.5	16	9	27	24	17	17
		HF-AE45M-8S-M14X1.5	8	14X1.5	19	12	28	27	19	19
		HF-AE45M-10S-M16X1.5	10	16X1.5	20	12.5	33	29	22	22
		HF-AE45M-12S-M18X1.5	12	18X1.5	21	13.5	33	30	24	24
		HF-AE45M-14S-M20X1.5	14	20X1.5	24	16	39	34	27	27
	400	HF-AE45M-16S-M22X1.5	16	22X1.5	24	15.5	40	34	27	30
		HF-AE45M-20S-M27X2	20	27X2	26.5	16	46	37.5	32	36
		HF-AE45M-25S-M33X2	25	33X2	31	19	46	43	41	46
		HF-AE45M-30S-M42X2	30	42X2	35	21.5	48	48	50	50
		HF-AE45M-38S-M48X2	38	48X2	39	23	50	54	55	60

ADJUSTABLE DIN MALE 45° STUD ELBOW WITH O-RING

Thread UNF/UN-2A

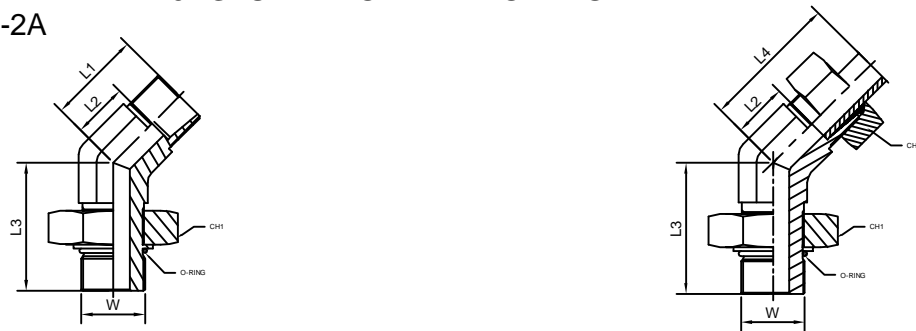

Series	W.P (Bar)	Part No.	Ø Tube	W	L1	L2	L3	L4	CH1	CH2
L	315	HF-AE45U-6L-7/16	6	7/16-20	16	9	26.5	24	14	14
		HF-AE45U-8L-7/16	8	7/16-20	19	12	26.5	27	14	17
		HF-AE45U-10L-9/16	10	9/16-18	19	12	29	27	17	19
		HF-AE45U-12L-3/4	12	3/4-16	21	14	33	29	22	22
		HF-AE45U-15L-7/8	15	7/8-14	24	17	39	32	27	27
	160	HF-AE45U-18L-7/8	18	7/8-14	24.5	17	39	33.5	27	32
		HF-AE45U-22L-1 1/16	22	1 1/16-12	26	18.5	44	35	32	36
		HF-AE45U-28L-1 5/16	28	1 5/16-12	30.5	23	47	39.5	41	41
		HF-AE45U-35L-1 5/8	35	1 5/8-12	33	22.5	48	44	50	50
		HF-AE45U-42L-1 7/8	42	1 7/8-12	37	26	48.5	49	55	60
S	630	HF-AE45U-6S-7/16	6	7/16-20	16	9	27	24	14	17
		HF-AE45U-8S-9/16	8	9/16-18	19	12	30	27	17	19
		HF-AE45U-10S-9/16	10	9/16-18	20	12.5	34	29	17	22
		HF-AE45U-12S-3/4	12	3/4-16	21	13.5	34	30	22	24
		HF-AE45U-14S-7/8	14	7/8-14	24	16	39	34	27	27
	400	HF-AE45U-16S-7/8	16	7/8-14	24	15.5	39	34	27	30
		HF-AE45U-20S-1 1/16	20	1 1/16-12	26.5	16	44	37.5	32	36
		HF-AE45U-25S-1 5/16	25	1 5/16-12	31	19	47	43	41	46
		HF-AE45U-30S-1 5/8	30	1 5/8-12	35	21.5	48	48	50	50
		HF-AE45U-38S-1 7/8	38	1 7/8-12	39	23	50	54	55	60

ADJUSTABLE DIN MALE STUD BARREL TEE WITH O-RING AND WASHER

Thread BSP Parallel - Thread Metric Parallel

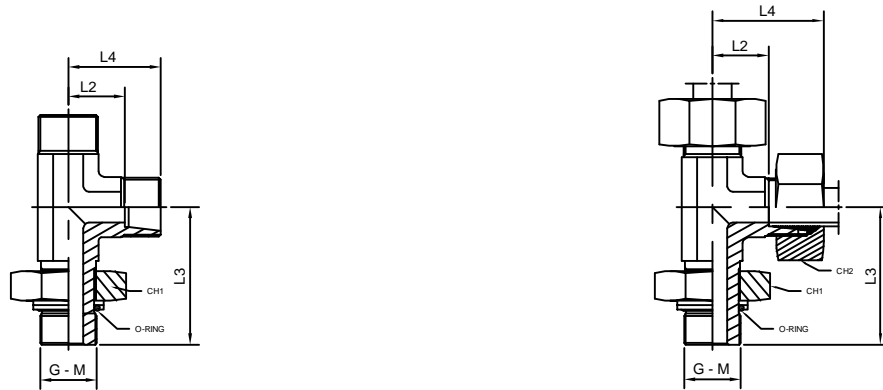

Series	W.P (Bar)	Part No.	Ø Tube	G	L1	L2	L3	L4	CH1	CH2
L	315	HF-ATRB-6L-1/8	6	1/8	19	12	26	27	14	14
		HF-ATRB-8L-1/4	8	1/4	21	14	32	29	19	17
		HF-ATRB-10L-1/4	10	1/4	22	15	32	30	19	19
		HF-ATRB-12L-3/8	12	3/8	24	17	37	32	22	22
	HF-ATRB-15L-1/2	15	1/2	28	21	44	36	27	27	
	HF-ATRB-18L-1/2	18	1/2	31	23.5	47	40	27	32	
	HF-ATRB-22L-3/4	22	3/4	35	27.5	51	44	36	36	
	HF-ATRB-28L-1	28	1	38	30.5	53	47	41	41	
S	630	HF-ATRB-6S-1/4	6	1/4	23	16	32	31	19	17
		HF-ATRB-8S-1/4	8	1/4	24	17	32	32	19	19
		HF-ATRB-10S-3/8	10	3/8	25	17.5	37	34	22	22
		HF-ATRB-12S-3/8	12	3/8	29	21.5	37	38	22	24
	HF-ATRB-14S-1/2	14	1/2	30	22	44	40	27	27	
	HF-ATRB-16S-1/2	16	1/2	33	24.5	47	43	27	30	
	HF-ATRB-20S-3/4	20	3/4	37	26.5	51	48	36	36	
	HF-ATRB-25S-1	25	1	42	30	53	54	41	46	
315	HF-ATRB-30S-1 1/4	30	1 1/4	49	35.5	59	62	50	50	
	HF-ATRB-38S-1 1/2	38	1 1/2	57	41	64	72	55	60	

Series	W.P (Bar)	Part No.	Ø Tube	M	L1	L2	L3	L4	CH1	CH2
L	315	HF-ATRM-6L-10X1	6	10X1	19	12	26	27	14	14
		HF-ATRM-8L-12X1.5	8	12X1.5	21	14	32	29	19	17
		HF-ATRM-10L-14X1.5	10	14X1.5	22	15	32	30	19	19
		HF-ATRM-12L-16X1.5	12	16X1.5	24	17	37	32	22	22
	HF-ATRM-15L-18X1.5	15	18X1.5	28	21	44	36	27	27	
	HF-ATRM-18L-22X1.5	18	22X1.5	31	23.5	47	40	27	32	
	HF-ATRM-22L-27X2	22	27X2	35	27.5	51	44	36	36	
	HF-ATRM-28L-33X2	28	33X2	38	30.5	53	47	41	41	
S	630	HF-ATRM-6S-12X1.5	6	12X1.5	23	16	32	31	19	17
		HF-ATRM-8S-14X1.5	8	14X1.5	24	17	32	32	19	19
		HF-ATRM-10S-16X1.5	10	16X1.5	25	17.5	37	34	22	22
		HF-ATRM-12S-18X1.5	12	18X1.5	29	21.5	37	38	22	24
	HF-ATRM-14S-20X1.5	14	20X1.5	30	22	44	40	27	27	
	HF-ATRM-16S-22X1.5	16	22X1.5	33	24.5	47	43	27	30	
	HF-ATRM-20S-27X2	20	27X2	37	26.5	51	48	36	36	
	HF-ATRM-25S-33X2	25	33X2	42	30	53	54	41	46	
315	HF-ATRM-30S-42X2	30	42X2	49	35.5	59	62	50	50	
	HF-ATRM-38S-48X2	38	48X2	57	41	64	72	55	60	

ADJUSTABLE DIN MALE STUD BARREL TEE WITH O-RING

Thread UNF/UN-2A

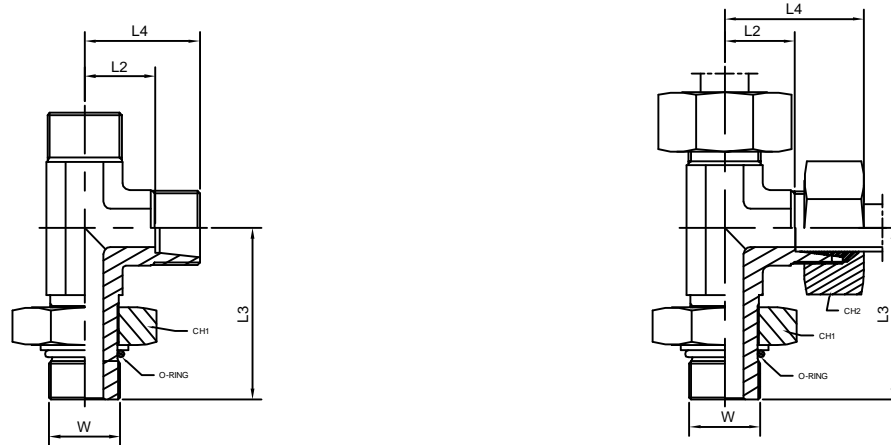

Series	W.P (Bar)	Part No.	Ø Tube	W	L1	L2	L3	L4	CH1	CH2
L	315	HF-ATRV-6L-7/16	6	7/16-20	19	12	27	27	14	14
		HF-ATRV-8L-7/16	8	7/16-20	21	14	28	29	14	17
		HF-ATRV-10L-9/16	10	9/16-18	22	15	32	30	17	19
		HF-ATRV-12L-3/4	12	3/4-16	24	17	37	32	22	22
		HF-ATRV-15L-7/8	15	7/8-14	28	21	43	36	27	27
	HF-ATRV-618L-7/8	18	7/8-14	31	23.5	47	40	27	32	
	160	HF-ATRV-22L-1 1/16	22	1 1/16-12	35	27.5	49.5	44	32	36
		HF-ATRV-28L-1 5/16	28	1 5/16-12	38	30.5	52	47	41	41
HF-ATRV-35L-5/8		35	1 5/8-12	45	34.5	58	56	50	50	
		HF-ATRV-42L-7/8	42	1 7/8-12	51	40	60	63	55	60
S	630	HF-ATRV-6S-7/16	6	7/16-20	23	16	29	31	14	17
		HF-ATRV-8S-9/16	8	9/16-18	24	17	33	32	17	19
		HF-ATRV-10S-9/16	10	9/16-18	25	17.5	37.5	34	17	22
		HF-ATRV-12S-3/4	12	3/4-16	29	21.5	38	38	22	24
	400	HF-ATRV-14S-7/8	14	7/8-14	30	22	44	40	27	27
		HF-ATRV-16S-7/8	16	7/8-14	33	24.5	48	43	27	30
		HF-ATRV-20S-1 1/16	20	1 1/16-12	37	26.5	51	48	32	36
		HF-ATRV-25S-1 5/16	25	1 5/16-12	42	30	53	54	41	46
		HF-ATRV-30S-1 5/8	30	1 5/8-12	49	35.5	59	62	50	50
		HF-ATRV-38S-1 7/8	38	1 7/8-12	57	41	62	72	55	60

ADJUSTABLE DIN MALE STUD BRANCH TEE WITH O-RING AND WASHER

Thread BSP Parallel - Thread Metric Parallel

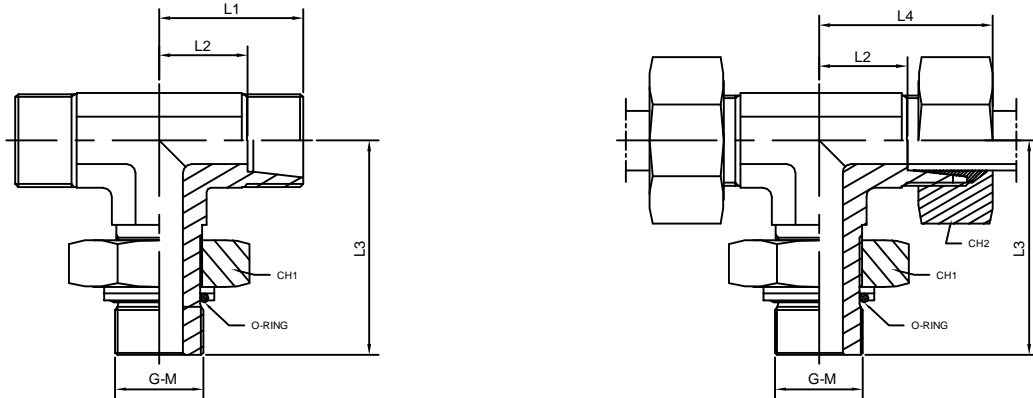

Series	W.P (Bar)	Part No.	Ø Tube	G	L1	L2	L3	L4	CH1	CH2
L	315	HF-ATBB-6L-1/8	6	1/8	19	12	26	27	14	14
		HF-ATBB-8L-1/4	8	1/4	21	14	32	29	19	17
		HF-ATBB-10L-1/4	10	1/4	22	15	32	30	19	19
		HF-ATBB-12L-3/8	12	3/8	24	17	37	32	22	22
		HF-ATBB-15L-1/2	15	1/2	28	21	44	36	27	27
	HF-ATBB-18L-1/2	18	1/2	31	23.5	47	40	27	32	
	160	HF-ATBB-22L-3/4	22	3/4	35	27.5	51	44	36	36
		HF-ATBB-28L-1	28	1	38	30.5	53	47	41	41
		HF-ATBB-35L-1 1/4	35	1 1/4	45	34.5	59	56	50	50
		HF-ATBB-42L-1 1/2	42	1 1/2	51	40	64	63	55	60
HF-ATBB-6S-1/4		6	1/4	23	16	32	31	19	17	
S	630	HF-ATBB-8S-1/4	8	1/4	24	17	32	32	19	19
		HF-ATBB-10S-3/8	10	3/8	25	17.5	37	34	22	22
		HF-ATBB-12S-3/8	12	3/8	29	21.5	37	38	22	24
		HF-ATBB-14S-1/2	14	1/2	30	22	44	40	27	27
		HF-ATBB-16S-1/2	16	1/2	33	24.5	47	43	27	30
	400	HF-ATBB-20S-3/4	20	3/4	37	26.5	51	48	36	36
		HF-ATBB-25S-1	25	1	42	30	53	54	41	46
		HF-ATBB-30S-1 1/4	30	1 1/4	49	35.5	59	62	50	50
		HF-ATBB-35S-1 1/2	35	1 1/2	57	41	64	72	55	60

Series	W.P (Bar)	Part No.	Ø Tube	M	L1	L2	L3	L4	CH1	CH2
L	315	HF-ATBM-6L-10X1	6	10X1	19	12	26	27	14	14
		HF-ATBM-8L-12X1.5	8	12X1.5	21	14	32	29	19	17
		HF-ATBM-10L-14X1.5	10	14X1.5	22	15	32	30	19	19
		HF-ATBM-12L-16X1.5	12	16X1.5	24	17	37	32	22	22
		HF-ATBM-15L-18X1.5	15	18X1.5	28	21	44	36	27	27
	HF-ATBM-18L-22X1.5	18	22X1.5	31	23.5	47	40	27	32	
	160	HF-ATBM-22L-27X2	22	27X2	35	27.5	51	44	36	36
		HF-ATBM-28L-33X2	28	33X2	38	30.5	53	47	41	41
		HF-ATBM-35L-42X2	35	42X2	45	34.5	59	56	50	50
		HF-ATBM-42L-48X2	42	48X2	51	40	64	63	55	60
HF-ATBM-6S-12X1.5		6	12X1.5	23	16	32	31	19	17	
S	630	HF-ATBM-8S-14X1.5	8	14X1.5	24	17	32	32	19	19
		HF-ATBM-10S-16X1.5	10	16X1.5	25	17.5	37	34	22	22
		HF-ATBM-12S-18X1.5	12	18X1.5	29	21.5	37	38	22	24
		HF-ATBM-14S-20X1.5	14	20X1.5	30	22	44	40	27	27
		HF-ATBM-16S-22X1.5	16	22X1.5	33	24.5	47	43	27	30
	400	HF-ATBM-20S-27X2	20	27X2	37	26.5	51	48	36	36
		HF-ATBM-25S-33X2	25	33X2	42	30	53	54	41	46
		HF-ATBM-30S-42X2	30	42X2	49	35.5	59	62	50	50
		HF-ATBM-35S-48X2	35	48X2	57	41	64	72	55	60

ADJUSTABLE DIN MALE STUD BRANCH TEE WITH O-RING

Thread UNF/UN-2A

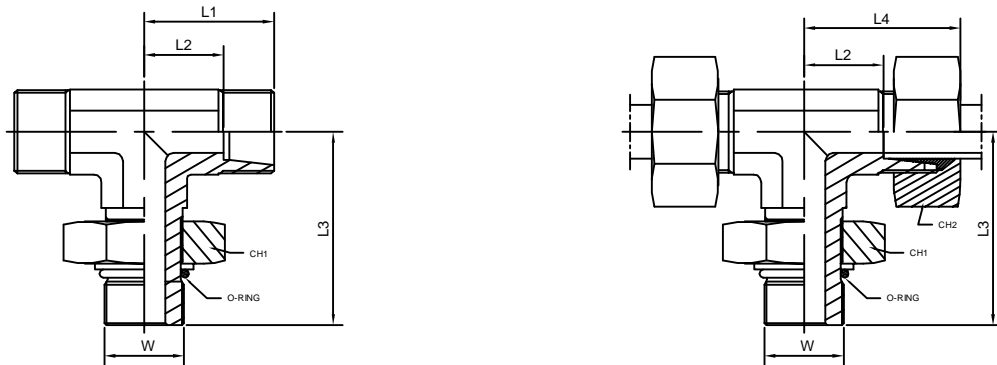

Series	W.P (Bar)	Part No.	Ø Tube	W	L1	L2	L3	L4	CH1	CH2
L	315	HF-ATBU-6L-7/16	6	7/16-20	19	12	27	27	14	14
		HF-ATBU-8L-7/16	8	7/16-20	21	14	28	29	14	17
		HF-ATBU-10L-9/16	10	9/16-18	22	15	32	30	17	19
		HF-ATBU-12L-3/4	12	3/4-16	24	17	37	32	22	22
		HF-ATBU-15L-7/8	15	7/8-14	28	21	43	36	27	27
	HF-ATBU-18L-7/8	18	7/8-14	31	23.5	47	40	27	32	
	160	HF-ATBU-22L-1 1/16	22	1 1/16-12	35	27.5	49.5	44	32	36
		HF-ATBU-28L-1 5/16	28	1 5/16-12	38	30.5	52	47	41	41
		HF-ATBU-35L-1 5/8	35	1 5/8-12	45	34.5	58	56	50	50
HF-ATBU-42L-1 7/8		42	1 7/8-12	51	40	60	63	55	60	
S	630	HF-ATBU-6S-7/16	6	7/16-20	23	16	29	31	14	17
		HF-ATBU-8S-9/16	8	9/16-18	24	17	33	32	17	19
		HF-ATBU-10S-9/16	10	9/16-18	25	17.5	37.5	34	17	22
		HF-ATBU-12S-3/4	12	3/4-16	29	21.5	38	38	22	24
		HF-ATBU-14S-7/8	14	7/8-14	30	22	44	40	27	27
	400	HF-ATBU-16S-7/8	16	7/8-14	33	24.5	48	43	27	30
		HF-ATBU-20S-1 1/16	20	1 1/16-12	37	26.5	51	48	32	36
		HF-ATBU-25S-1 5/16	25	1 5/16-12	42	30	53	54	41	46
		HF-ATBU-30S-1 5/8	30	1 5/8-12	49	35.5	59	62	50	50
		HF-ATBU-38S-1 7/8	38	1 7/8-12	57	41	62	72	55	60
	315	HF-ATBU-38S-1 7/8	38	1 7/8-12	57	41	62	72	55	60

BLANKING PLUG WITH O-RING - Per cono a 24° DIN 3861



Series	W.P (Bar)	Part No.	Ø Tube	D1	L1	CH1
L	315	HF-BE-6L	6	6	17	14
		HF-BE-8L	8	8	17	17
		HF-BE-10L	10	10	20	19
		HF-BE-12L	12	12	21	22
		HF-BE-15L	15	15	21	27
	HF-BE-18L	18	18	23	32	
	160	HF-BE-22L	22	22	23	36
		HF-BE-28L	28	28	25	41
		HF-BE-35L	35	35	29	50
HF-BE-42L		42	42	30	60	
S	630	HF-BE-6S	6	6	17	17
		HF-BE-8S	8	8	17	19
		HF-BE-10S	10	10	20	22
		HF-BE-12S	12	12	21	24
		HF-BE-14S	14	14	23	27
	400	HF-BE-16S	16	16	24	30
		HF-BE-20S	20	20	28	36
		HF-BE-25S	25	25	31	46
		HF-BE-30S	30	30	34	50
		HF-BE-38S	38	38	38	60
	315	HF-BE-38S	38	38	38	60

MALE - FEMALE ADAPTER WITH ELASTOMER SEAL

Thread BSP Parallel

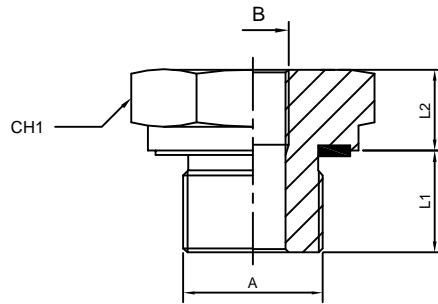

Series	W.P (Bar)	Part No.	A	B	L1	L2	CH1
L/S	400	HF-RI-3/8X1/8	3/8	1/8	12	10.5	22
		HF-RI-1/2X1/8	1/2	1/8	14	10	27
		HF-RI-1/2X1/4	1/2	1/4	14	10	27
	315	HF-RI-3/4X1/4	3/4	1/4	16	10	32
		HF-RI-3/4X3/8	3/4	3/8	16	10	32
		HF-RI-1X1/4	1	1/4	18	11	41
		HF-RI-1X3/8	1	3/8	18	11	41
		HF-RI-1X1/2	1	1/2	18	11	41
		HF-RI-1 1/4X1/2	1 1/4	1/2	20	12	50
	250	HF-RI-1 1/4X3/4	1 1/4	3/4	20	12	50
		HF-RI-1 1/2X1/2	1 1/2	1/2	22	14	55
		HF-RI-1 1/2X3/4	1 1/2	3/4	22	14	55
		HF-RI-1 1/2X1	1 1/2	1	22	14	55

MALE - FEMALE ADAPTER WITH ELASTOMER SEAL

Thread BSP Parallel

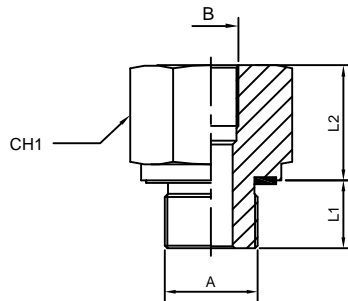

Series	W.P (Bar)	Part No.	A	B	L1	L2	CH1
L/S	400	HF-RI-1/8X1/4	1/8	1/4	8	23	19
		HF-RI-1/8X3/8	1/8	3/8	8	24	24
		HF-RI-1/4X1/8	1/4	1/8	12	16	19
		HF-RI-1/4X3/8	1/4	3/8	12	24	24
		HF-RI-1/4X1/2	1/4	1/2	12	28	30
		HF-RI-1/4X3/4	1/4	3/4	12	31	36
		HF-RI-3/8X1/4	3/8	1/4	12	24	22
	315	HF-RI-3/8X1/2	3/8	1/2	12	29	30
		HF-RI-3/8X3/4	3/8	3/4	12	32	36
	400	HF-RI-1/2X3/8	1/2	3/8	14	22	27
		HF-RI-1/2X3/4	1/2	3/4	14	32	36
	315	HF-RI-1/2X1	1/2	1	14	35	41
		HF-RI-1/2X1 1/4	1/2	1 1/4	14	39	55
		HF-RI-3/4X1/2	3/4	1/2	16	26	32
		HF-RI-3/4X1	3/4	1	16	35	41
		HF-RI-3/4X1 1/4	3/4	1 1/4	16	39	55
	250	HF-RI-3/4X1 1/2	3/4	1 1/2	16	41	60
	315	HF-RI-1X3/4	1	3/4	18	29	41
		HF-RI-1X1 1/4	1	1 1/4	18	39	55
	250	HF-RI-1X1 1/2	1	1 1/2	18	41	60
	315	HF-RI-1 1/4X1	1 1/4	1	20	31	50
	250	HF-RI-1 1/4X1 1/2	1 1/4	1 1/2	20	40	60
		HF-RI-1 1/2X1 1/4	1 1/2	1 1/4	22	36	55

CLOSURE PLUG WITH EXAGON SOCKET HEAD WITH ELASTOMER SEAL

Thread BSP Parallel - Thread Metric Parallel

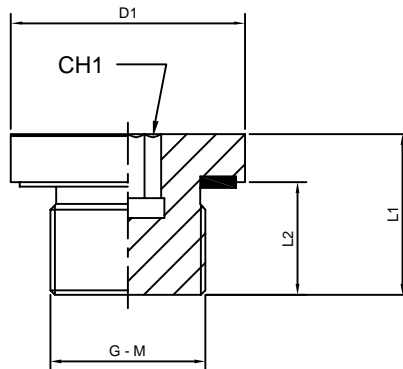

Series	W.P (Bar)	Part No.	G	D1	L1	L2	CH1
S	400	HF-AP-1/8ED	1/8	14	12	8	5
		HF-AP-1/4ED	1/4	19	17	12	6
		HF-AP-3/8ED	3/8	22	17	12	8
		HF-AP-1/2ED	1/2	27	19	14	10
		HF-AP-3/4ED	3/4	32	21	16	12
	HF-AP-1ED	1	40	22.5	16	17	
	250	HF-AP-1 1/4ED	1 1/4	50	22.5	16	22
		HF-AP-1 1/2ED	1 1/2	55	22.5	16	24

Series	W.P (Bar)	Part No.	M	D1	L1	L2	CH1
S	400	HF-AP-M10X1ED	10X1	14	12	8	5
		HF-AP-M12X1.5ED	12X1.5	19	17	12	6
		HF-AP-M14X1.5ED	14X1.5	22	17	12	8
		HF-AP-M16X1.5ED	16X1.5	27	19	14	10
		HF-AP-M18X1.5ED	18X1.5	32	21	16	12
		HF-AP-M20X1.5ED	20X1.5	40	22.5	16	17
	250	HF-AP-M22X1.5ED	22X1.5	50	22.5	16	22
		HF-AP-M26X1.5ED	26X1.5	55	22.5	16	24

BLANKING PLUG FOR TUBE ENDS

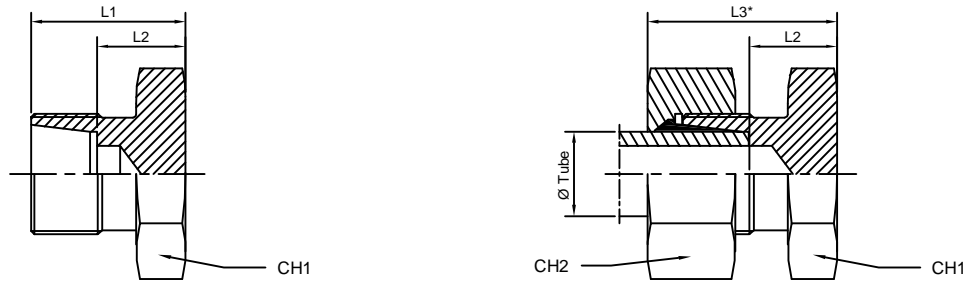

Series	W.P (Bar)	Part No.	Ø Tube	L1	L2	L3*	CH1	CH2	
L	315	HF-BP-6L	6	14	7	21,5	12	14	
		HF-BP-8L	8	15	8	23	14	17	
		HF-BP-10L	10	16	9	24	17	19	
		HF-BP-12L	12	17	10	24,5	19	22	
		HF-BP-15L	15	18	11	26	24	27	
	HF-BP-18L	18	19	11,5	28	27	32		
	160	HF-BP-22L	22	21	13,5	30	32	36	
		HF-BP-28L	28	22	14,5	31	41	41	
HF-BP-35L		35	25	14,5	36	46	50		
S	630	HF-BP-42L	42	27	16	39	55	60	
		HF-BP-6S	6	18	11	26	14	17	
		HF-BP-8S	8	20	13	28	17	19	
		HF-BP-10S	10	20	12,5	28,5	19	22	
	400	HF-BP-12S	12	22	14,5	30,5	22	24	
		HF-BP-14S	14	24	16	34	24	27	
		HF-BP-16S	16	24	15,5	34	27	30	
		HF-BP-20S	20	28	17,5	39	32	36	
		HF-BP-25S	25	32	20	44	41	46	
		HF-BP-30S	30	34	20,5	47	46	50	
		315	HF-BP-38S	38	39	23	54	55	60

ALLOW SCREW FOR BANJOS - Thread BSP Parallel - Thread Metric Parallel



Series	W.P (Bar)	Part No.	G	D1	L1	CH1
L/S	-	HF-B-1/8	1/8	4	32	17
		HF-B-1/4	1/4	5	44	19
		HF-B-3/8	3/8	8	50,5	24
		HF-B-1/2	1/2	10	60,5	30
		HF-B-3/4	3/4	14,5	70	36
		HF-B-1	1	21	84,5	46
		HF-B-1 1/4	1 1/4	26	100	55
		HF-B-1 1/2	1 1/2	30	112	60
		HF-B-1/8	1/8	4	27,5	14
		HF-B-1/4	1/4	5	36,5	19
		HF-B-3/8	3/8	8	41,5	22
		HF-B-1/2	1/2	10	55	27
L/S	-	HF-B-3/4	3/4	14,5	61	32
		HF-B-8X1	8X1	3	32	14
		HF-B-10X1	10X1	4	32	17
		HF-B-12X1.5	12X1.5	4	44	19
		HF-B-14X1.5	14X1.5	5	44	19
		HF-B-16X1.5	16X1.5	8	50,5	24
		HF-B-18X1.5	18X1.5	8	54	27
		HF-B-20X1.5	20X1.5	10	59	30
		HF-B-22X1.5	22X1.5	10	60,5	30
		HF-B-26X1.5	26X1.5	14,5	70	36
		HF-B-27X2	27X2	14,5	70	36
		HF-B-33X2	33X2	21	84,5	46
		HF-B-42X2	42X2	26	100	55
		HF-B-48X2	48X2	30	112	60
		HF-B-8X1	8X1	3	27,5	12
		HF-B-10X1	10X1	4	27,5	14
		HF-B-12X1.5	12X1.5	4	36,5	17
		HF-B-14X1.5	14X1.5	5	36,5	19
		HF-B-16X1.5	16X1.5	8	41,5	22
		HF-B-18X1.5	18X1.5	8	46	24
		HF-B-20X1.5	20X1.5	10	55	27
		HF-B-22X1.5	22X1.5	10	55	27
		HF-B-26X1.5	26X1.5	14,5	61	32
		HF-B-27X2	27X2	14,5	61	32

SEALING WASHER

Gauge fitting - Adjustable elbow
Thread BSP Parallel - Thread Metric Parallel

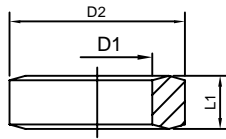

O-RING SEALING WASHER

Gauge fitting
Thread BSP Parallel

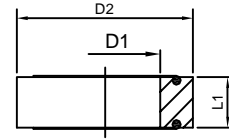

Series	W.P (Bar)	Part No.	D1	D2	L1	Thread
L/S		HF-SW-	6	11	4.5	G 1/4
		HF-SW-	9	18	5	G 1/2
		HF-SW-	9.8	14.5	3	G 1/8
		HF-SW-	13.3	18	3	G 1/4
		HF-SW-	16.8	22	3	G 3/8
		HF-SW-	21.1	26	4	G 1/2
		HF-SW-	26.5	32	4	G 3/4
		HF-SW-	8.1	12.5	3	M 8X1
		HF-SW-	10.1	14.5	3	M 10X1
		HF-SW-	12.1	17	3	M 12X1.5
		HF-SW-	14.1	19	3	M 14X1.5
		HF-SW-	16.1	21	3	M 16X1.5
		HF-SW-	18.1	23	3	M 18X1.5
		HF-SW-	20.1	25	4	M 20X1.5
L/S		HF-SW-	22.1	27	4	M 22X1.5
		HF-SW-	26.1	32	4	M 26X1.5
		HF-SW-	27.1	32	4	M 27X2
		HF-SW-	6	11	4.5	1/4
		HF-SW-	9	18	5	1/2

PIPE INSERT

Thin wall pipe

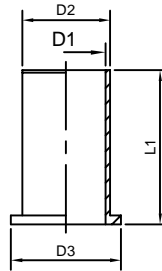

Series	W.P (Bar)	Part No.	ØTube	D1	D2	D3	L1
L/S		HF-PI-6L/S	6	3	3.9	6	11
		HF-PI-8L/S	8	5	5.9	8	14
		HF-PI-10L/S	10	7	7.9	10	15
		HF-PI-12L/S	12	9	9.9	12	16
		HF-PI-15L/S	15	12	12.9	15	17
		HF-PI-18L/S	18	14	14.9	18	20
		HF-PI-20L/S	20	15	15.9	20	20
		HF-PI-22L/S	22	16	17.9	22	20
		HF-PI-28L/S	28	22	23.9	28	23.5
		HF-PI-30L/S	30	24	25.9	30	23.5
		HF-PI-35L/S	35	28	30.9	35	26.5

EXAGONAL NUT

Bulkhead fitting

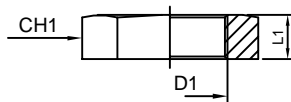

Series	W.P (Bar)	Part No.	m	L1	CH1	Ø Tube	Ø Tube
L/S		HF-L/N-M12X1.5	12X1.5	6	17	6L	-
		HF-L/N-M14X1.5	14X1.5	6	19	8L	6S
		HF-L/N-M16X1.5	16X1.5	6	22	10L	8S
		HF-L/N-M18X1.5	18X1.5	6	24	12L	10S
		HF-L/N-M20X1.5	20X1.5	6	27	-	12S
		HF-L/N-M22X1.5	22X1.5	7	30	15L	14S
		HF-L/N-M24X1.5	24X1.5	7	32	-	16S
		HF-L/N-M26X1.5	26X1.5	8	36	18L	-
		HF-L/N-M30X2	30X2	8	41	22L	20S
		HF-L/N-M36X2	36X2	9	46	28L	25S
		HF-L/N-M42X2	42X2	9	50	-	30S
		HF-L/N-M45X2	45X2	9	55	35L	-
		HF-L/N-M52X2	52X2	10	65	42L	38S

MALE STUD COUPLING WITH O-RING AND WASHER

Thread BSP Parallel - Thread Metric Parallel

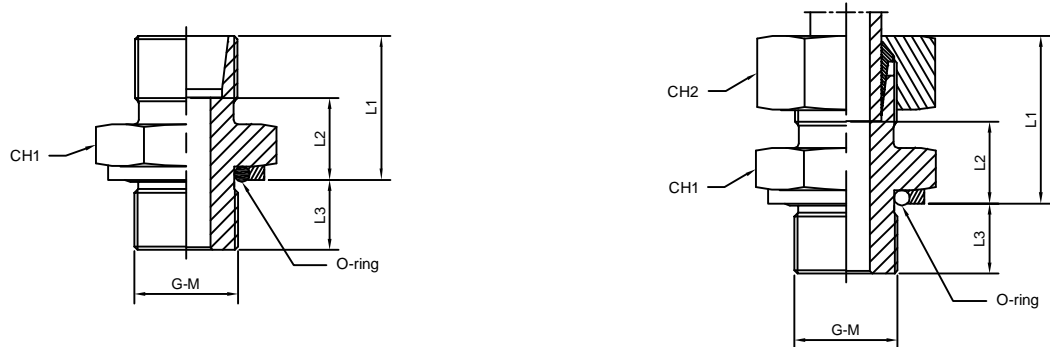

Series	W.P (Bar)	Part No.	Ø Tube	G	L1	L2	L3	L4	CH1	CH2
LL	100	HF-MSBW-4LL-1/8	4	1/8	13.3	9.3	6.7	19.8	14	10
		HF-MSBW-6LL-1/8	6	1/8	13.3	7.8	6.7	19.8	14	12
		HF-MSBW-8LL-1/8	8	1/8	14.3	8.8	6.7	20.8	14	14
L	315	HF-MSBW-6L-1/8	6	1/8	15.3	8.3	6.7	22.8	14	14
		HF-MSBW-8L-1/4	8	1/4	16.8	9.8	10.2	24.8	19	17
		HF-MSBW-10L-1/4	10	1/4	17.8	10.8	10.2	25.8	19	19
		HF-MSBW-12L-3/8	12	3/8	19.3	12.3	10.2	26.8	22	22
		HF-MSBW-15L-1/2	15	1/2	20.8	13.8	12.2	28.8	27	27
		HF-MSBW-18L-1/2	18	1/2	21.8	14.3	12.2	30.8	27	32
	160	HF-MSBW-22L-3/4	22	3/4	23.8	16.3	12.7	32.8	36	36
		HF-MSBW-28L-1	28	1	25.1	17.6	15.4	34.1	41	41
		HF-MSBW-35L-1 1/4	35	1 1/4	28.1	17.6	16	39.1	50	50
		HF-MSBW-42L-1 1/2	42	1 1/2	30.1	19.1	16	42.1	55	60
S	630	HF-MSBW-6S-1/4	6	1/4	19.8	12.8	10.2	27.8	19	17
		HF-MSBW-8S-1/4	8	1/4	21.8	14.8	10.2	29.8	19	19
		HF-MSBW-10S-3/8	10	3/8	22.3	14.8	10.2	30.8	22	22
		HF-MSBW-12S-3/8	12	3/8	24.3	16.8	10.2	32.8	22	24
		HF-MSBW-14S-1/2	14	1/2	26.8	18.8	12.2	36.8	27	27
	400	HF-MSBW-16S-1/2	16	1/2	26.8	18.3	12.2	36.8	27	30
		HF-MSBW-20S-3/4	20	3/4	30.8	20.3	12.7	41.8	36	36
		HF-MSBW-25S-1	25	1	35.1	23.1	15.4	47.1	41	46
		HF-MSBW-30S-1 1/4	30	1 1/4	37.1	23.6	16	50.1	50	50
		HF-MSBW-38S-1 1/2	38	1 1/2	42.1	26.1	16	57.1	55	60

Series	W.P (Bar)	Part No.	Ø Tube	M	L1	L2	L3	L4	CH1	CH2
LL	100	HF-MSBW-4LL-M8x1	4	8X1	13.5	9.5	7.5	20	12	10
		HF-MSBW-6LL-M10x1	6	10X1	13.5	8	7.5	20	14	12
		HF-MSBW-8LL-M10x1	8	10X1	14.5	9	7.5	21	14	14
L	315	HF-MSBW-6L-M10x1	6	10X1	15.5	8.5	7.5	23	14	14
		HF-MSBW-8L-M12x1.5	8	12X1.5	16.9	9.9	9.6	24.9	17	17
		HF-MSBW-10L-M14x1.5	10	14X1.5	17.9	10.9	9.6	25.9	19	19
		HF-MSBW-12L-M16x1.5	12	16X1.5	19.4	12.4	11.1	26.9	22	22
		HF-MSBW-15L-M18x1.5	15	18X1.5	20.4	13.4	12.6	28.3	27	27
		HF-MSBW-18L-M22x1.5	18	22X1.5	21.9	14.4	13.6	30.3	27	32
	160	HF-MSBW-22L-M27x2	22	27X2	24	16.5	16.5	33	36	36
		HF-MSBW-28L-M33x2	28	33X2	25	17.5	16.5	34	41	41
		HF-MSBW-35L-M42x2	35	42X2	28	17.5	17	39	50	50
		HF-MSBW-42L-M48x2	42	48X2	30	19	19.5	42	55	60
S	630	HF-MSBW-6S-M12x1.5	6	12X1.5	19.9	12.9	9.6	27.9	19	17
		HF-MSBW-8S-M14x1.5	8	14X1.5	21.9	14.9	9.6	29.9	19	19
		HF-MSBW-10S-M16x1.5	10	16X1.5	22.4	14.9	11.1	30.9	22	22
		HF-MSBW-12S-M18x1.5	12	18X1.5	24.4	16.9	12.6	32.9	22	24
		HF-MSBW-14S-M20x1.5	14	20X1.5	26.9	18.9	12.6	36.9	27	27
	400	HF-MSBW-16S-M22x1.5	16	22X1.5	26.9	18.4	13.6	36.9	27	30
		HF-MSBW-20S-M27x2	20	27X2	31	20.5	16.5	42	36	36
		HF-MSBW-25S-M33x2	25	33X2	35	23	16.5	47	41	46
		HF-MSBW-30S-M42x2	30	42X2	37	23.5	17	50	50	50
		HF-MSBW-38S-M48x2	38	48X2	42	26	19.5	57	55	60

MALE STUD COUPLING WITH SWIVEL NUT AND ELASTOMER SEAL

Thread BSP Parallel

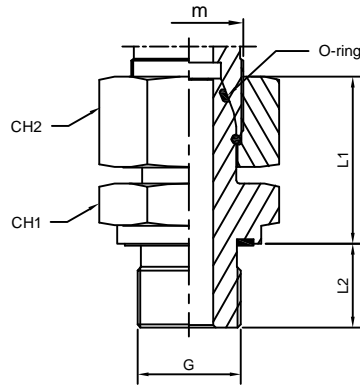

Series	W.P (Bar)	Part No.	Ø Tube	m	G	L1	L2	CH1	CH2
L	500	HF-STP-6L-1/8-ED	6	12X1.5	1/8	24.5	8	14	14
		HF-STP-8L-1/4-ED	8	14X1.5	1/4	29.5	12	19	17
		HF-STP-10L-1/4-ED	10	16X1.5	1/4	27.5	12	19	19
	400	HF-STP-12L-3/8-ED	12	18X1.5	3/8	34	12	22	22
		HF-STP-15L-1/2-ED	15	22X1.5	1/2	32	14	27	27
	315	HF-STP-18L-1/2-ED	18	26X1.5	1/2	31.5	14	27	32
		HF-STP-22L-3/4-ED	22	30X2	3/4	32.5	16	32	36
		HF-STP-28L-1-ED	28	36X2	1	35	18	41	41
HF-STP-35L-1 1/4-ED		35	45X2	1 1/4	42.5	20	50	50	
HF-STP-42L-1 1/2-ED		42	52X2	1 1/2	46.5	22	55	60	
S	800	HF-STP-6S-1/4-ED	6	14X1.5	1/4	27	12	19	17
		HF-STP-8S-1/4-ED	8	16X1.5	1/4	29.5	12	19	19
		HF-STP-10S-3/8-ED	10	18X1.5	3/8	32.5	12	22	22
	630	HF-STP-12S-3/8-ED	12	20X1.5	3/8	34.5	12	22	24
		HF-STP-14S-1/2-ED	14	22X1.5	1/2	36.5	14	27	27
		HF-STP-16S-1/2-ED	16	24X1.5	1/2	37	14	27	30
	420	HF-STP-20S-3/4-ED	20	30X2	3/4	43	16	32	36
		HF-STP-25S-1-ED	25	36X2	1	48	18	41	46
		HF-STP-30S-1 1/4-ED	30	42X2	1 1/4	51	20	50	50
		HF-STP-38S-1 1/2-ED	38	52X2	1 1/2	60	22	55	60
L	500	HF-STP-6L-1/4-ED	6	12X1.5	1/4	27	12	19	14
		HF-STP-10L-3/8-ED	10	16X1.5	3/8	29	12	22	19
	400	HF-STP-12L-1/4-ED	12	18X1.5	1/4	27.5	12	19	22
		HF-STP-12L-1/2-ED	12	18X1.5	1/2	30	14	27	22
		HF-STP-15L-3/8-ED	15	22X1.5	3/8	31.5	12	22	27
	315	HF-STP-15L-3/4-ED	15	22X1.5	3/4	30.5	16	32	27
		HF-STP-18L-3/4-ED	18	26X1.5	3/4	31.5	16	32	32
		HF-STP-22L-1-ED	22	30X2	1	34	18	41	36
250	HF-STP-28L-3/4-ED	28	36X2	3/4	33.5	16	32	41	
	HF-STP-35L-1-ED	35	45X2	1	39.5	18	41	50	
	HF-STP-35L-1 1/2-ED	35	45X2	1 1/2	46.5	22	55	50	
S	800	HF-STP-6S-1/8-ED	6	14X1.5	1/8	24.5	8	14	17
		HF-STP-8S-3/8-ED	8	16X1.5	3/8	31.5	12	22	19
		HF-STP-10S-1/4-ED	10	18X1.5	1/4	30.5	12	19	22
		HF-STP-10S-1/2-ED	10	18X1.5	1/2	32	14	27	22
	630	HF-STP-12S-1/4-ED	12	20X1.5	1/4	30.5	12	19	24
		HF-STP-12S-1/2-ED	12	20X1.5	1/2	34	14	27	24
		HF-STP-14S-3/8-ED	14	22X1.5	3/8	37	12	22	27
		HF-STP-16S-3/8-ED	16	24X1.5	3/8	39.5	12	22	30
	420	HF-STP-20S-1/2-ED	20	30X2	1/2	41.5	14	27	36
		HF-STP-20S-1-ED	20	30X2	1	45.5	18	41	36
		HF-STP-25S-1/2-ED	25	36X2	1/2	42	14	32	46
		HF-STP-25S-3/4-ED	25	36X2	3/4	45.5	16	32	46
		HF-STP-25S-1 1/4-ED	25	36X2	1 1/4	48.5	20	50	46
		HF-STP-30S-1-ED	30	42X2	1	50.5	18	41	50
		HF-STP-30S-1 1/2-ED	30	42X2	1 1/2	58	22	55	50
		HF-STP-38S-1 1/4-ED	38	52X2	1 1/4	53	20	50	60

MALE STUD COUPLING WITH SWIVEL NUT AND ELASTOMER SEAL
Thread Metric Parallel

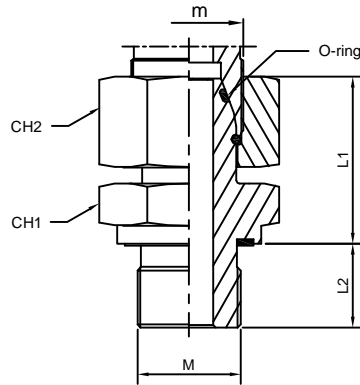

Series	W.P (Bar)	Part No.	Ø Tube	m	M	L1	L2	CH1	CH2	
L	500	HF-STP-6L-M10x1	6	12X1.5	10x1	24.5	8	14	14	
		HF-STP-8L-M12x1.5	8	14X1.5	12x1.5	26.5	12	17	17	
		HF-STP-10L-M14X1.5	10	16X1.5	14x1.5	27.5	12	19	19	
	400	HF-STP-12L-M16X1.5	12	18X1.5	16x1.5	30.5	12	22	22	
		HF-STP-15L-M18X1.5	15	22X1.5	18x1.5	31.5	12	24	27	
		HF-STP-18L-M22X1.5	18	26X1.5	22x1.5	31.5	14	27	32	
	250	HF-STP-22L-M26X1.5	22	30X2	26x1.5	32.5	16	32	36	
		HF-STP-28L-M33X2	28	36X2	33x2	35	18	41	41	
		HF-STP-35L-M42X2	35	45X2	42x2	42.5	20	50	50	
		HF-STP-42L-M48X2	42	52X2	48x2	46	22	55	60	
S	800	HF-STP-6S-M12X1.5	6	14X1.5	12x1.5	27	12	17	17	
		HF-STP-8S-M14X1.5	8	16X1.5	14x1.5	29.5	12	19	19	
		HF-STP-10S-M16X1.5	10	18X1.5	16x1.5	32.5	12	22	22	
	630	HF-STP-12S-M18X1.5	12	20X1.5	18x1.5	34.5	12	24	24	
		HF-STP-14S-M20X1.5	14	22X1.5	20x1.5	36.5	14	27	27	
		HF-STP-16S-22X1.5	16	24X1.5	22x1.5	37	14	27	30	
	420	HF-STP-20S-M27X2	20	30X2	27x2	43	16	32	36	
		HF-STP-25S-M33X2	25	36X2	33x2	48	18	41	46	
		HF-STP-30S-M42X2	30	42X2	42x2	51	20	50	50	
		HF-STP-38S-M48X2	38	52X2	48x2	60	22	55	60	
L	500	HF-STP-6L-M12X1.5	6	12X1.5	12x1.5	26.5	12	17	14	
		HF-STP-8L-M14X1.5	8	14x1.5	14x1.5	27	12	19	17	
		HF-STP-10L-M16X1.5	10	16x1.5	16x1.5	30.5	12	22	19	
	400	HF-STP-12L-M14X1.5	12	18x1.5	14x1.5	27.5	12	19	22	
		HF-STP-12L-M18X1.5	12	18x1.5	18x1.5	29.5	12	24	22	
		HF-STP-12L-M22X1.5	12	18x1.5	22x1.5	30	14	27	22	
			HF-STP-15L-M22X1.5	15	22x1.5	22x1.5	30.5	14	27	27
	250	HF-STP-18L-M26X1.5	18	26x1.5	26x1.5	31.5	16	32	32	
	500	HF-STP-6L-M10X1	6	14x1.5	10x1	24.5	8	14	17	
	800	HF-STP-8L-M12X1.5	8	16x1.5	12x1.5	27.5	12	17	19	
			HF-STP-10L-M14X1.5	10	18x1.5	14x1.5	30.5	12	19	22
	S	630	HF-STP-12S-M14X1.5	12	20x1.5	14x1.5	30.5	12	19	24
HF-STP-12S-M16X1.5			12	20x1.5	16x1.5	34.5	12	22	24	
HF-STP-12S-M22X1.5			12	20x1.5	22x1.5	35	14	27	24	

MALE STUD COUPLING WITH SWIVEL NUT O-RING AND WASHER

Thread BSP Parallel - Thread Metric Parallel

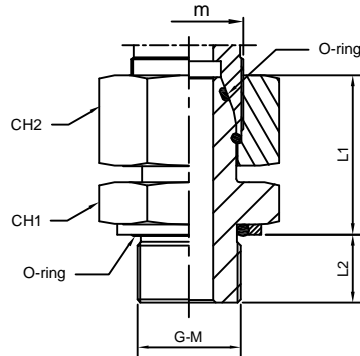

Series	W.P (Bar)	Part No.	Ø Tube	m	G	L1	L2	CH1	CH2
L	315	HF-STPW-6L-1/8	6	12X1.5	1/8	25.8	6.7	14	14
		HF-STPW-8L-1/4	8	14X1.5	1/4	31.3	10.2	19	17
		HF-STPW-10L-1/4	10	16X1.5	1/4	29.3	10.2	19	19
		HF-STPW-12L-3/8	12	18X1.5	3/8	35.8	10.2	22	22
		HF-STPW-15L-1/2	15	22X1.5	1/2	33.8	12.2	27	27
	HF-STPW-18L-1/2	18	26X1.5	1/2	33.3	12.2	27	32	
	160	HF-STPW-22L-3/4	22	30X2	3/4	34.3	12.7	36	36
		HF-STPW-28L-1	28	36X2	1	37.6	15.4	41	41
HF-STPW-35L-1 1/4		35	45X2	1 1/4	45	16	50	50	
		HF-STPW-42L-1 1/2	42	52X2	1 1/2	49	16	55	60
S	400	HF-STPW-6S-1/4	6	14X1.5	1/4	28.8	10.2	19	17
		HF-STPW-8S-1/4	8	16X1.5	1/4	31.3	10.2	19	19
	315	HF-STPW-10S-3/8	10	18X1.5	3/8	34.3	10.2	22	22
		HF-STPW-12S-3/8	12	20X1.5	3/8	36.3	10.2	22	24
		HF-STPW-14S-1/2	14	22X1.5	1/2	38.3	12.2	27	27
		HF-STPW-16S-3/8.8	16	24X1.5	1/2	38.8	12.2	27	30
		HF-STPW-20S-3/4	20	30X2	3/4	44.8	12.7	36	36
	280	HF-STPW-25S-1	25	36X2	1	50.6	15.4	41	46
		HF-STPW-30S-1 1/4	30	42X2	1 1/4	53.5	16	50	50
	250	HF-STPW-38S-1 1/2	38	52X2	1 1/2	62.5	16	55	60

Series	W.P (Bar)	Part No.	Ø Tube	m	M	L1	L2	CH1	CH2
L	315	HF-STPW-6L-M10x1	6	12X1.5	10x1	25	7.5	14	14
		HF-STPW-8L-M12x1.5	8	14X1.5	12x1.5	28.9	9.6	17	17
		HF-STPW-10L-M14x1.5	10	16X1.5	14x1.5	29.9	9.6	19	19
		HF-STPW-12L-M16x1.5	12	18X1.5	16x1.5	31.4	11.1	22	22
		HF-STPW-15L-M18x1.5	15	22X1.5	18x1.5	30.9	12.6	24	27
	HF-STPW-18L-M22x1.5	18	26X1.5	22x1.5	31.9	13.6	27	32	
	160	HF-STPW-22L-M27x2	22	30X2	27x2	32	16.5	32	36
		HF-STPW-28L-M33x2	28	36X2	33x2	36.5	16.5	41	41
HF-STPW-35L-M42x2		35	45X2	42x2	45.5	17	50	50	
		HF-STPW-42L-M48x2	42	52X2	48x2	47.5	19.5	55	60
S	400	HF-STPW-6S-M12x1.5	6	14X1.5	12x1.5	28.4	9.6	17	17
		HF-STPW-8S-M14x1.5	8	16X1.5	14x1.5	30.9	9.6	19	19
		HF-STPW-10S-M16x1.5	10	18X1.5	16x1.5	33.4	11.1	22	22
		HF-STPW-12S-M18x1.5	12	20X1.5	18x1.5	33.9	12.6	24	24
	315	HF-STPW-14S-M20x1.5	14	22X1.5	20x1.5	35.4	12.6	27	27
		HF-STPW-16S-M22x1.5	16	24X1.5	22x1.5	36.4	13.6	27	30
		HF-STPW-20S-M27x2	20	30X2	27x2	42.5	16.5	32	36
	280	HF-STPW-25S-M33x2	25	36X2	33x2	46.5	16.5	41	46
		HF-STPW-30S-M42x2	30	42X2	42x2	52	17	50	50
	250	HF-STPW-38S-M48x2	38	52X2	48x2	62.5	19.5	55	60

MALE STUD COUPLING WITH SWIVEL NUT AND O-RING
Thread UNF/UN-2A

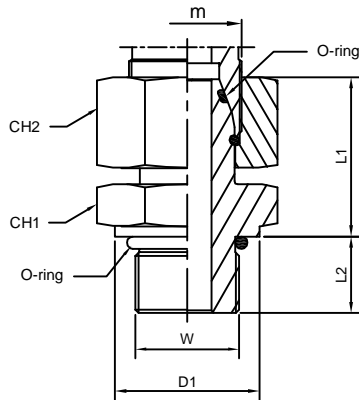

MALE STUD COUPLING WITH SWIVEL NUT
Thread NPT

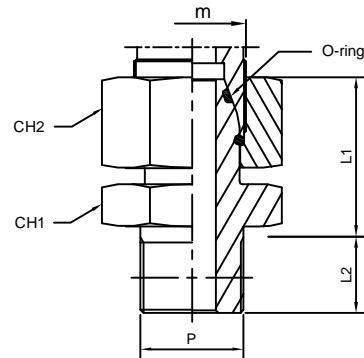

Series	W.P (Bar)	Part No.	Ø Tube	m	W	D1	L1	L2	CH1	CH2
L	315	HF-STU-6L-7/16	6	12X1.5	7/16-20	13.8	24.4	9.1	14	14
		HF-STU-8L-7/16	8	14X1.5	7/16-20	13.8	24.4	9.1	14	17
		HF-STU-10L-9/16	10	16X1.5	9/16-18	18.8	27.5	10	19	19
		HF-STU-12L-3/4	12	18X1.5	3/4-16	21.8	33.9	11.1	22	22
		HF-STU-15L-7/8	15	22X1.5	7/8-14	26.8	32.3	12.7	27	27
	HF-STU-18L-7/8	18	26X1.5	7/8-14	26.8	31.8	12.7	27	32	
	160	HF-STU-22L-1 1/6	22	30X2	1 1/16-12	31.8	32.4	15.1	32	36
		HF-STU-28L-1 5/16	28	36X2	1 5/16-12	40.8	34.9	15.1	41	41
HF-STU-35L-1 5/8		35	45X2	1 5/8-12	49.8	42.4	15.1	50	50	
S	630	HF-STU-6S-7/16	6	14X1.5	7/16-20	13.8	26.9	9.1	14	17
		HF-STU-8S-9/16	8	16X1.5	9/16-18	18.8	29.5	10	17	19
		HF-STU-10S-9/16	10	18X1.5	9/16-18	18.8	30.5	10	17	22
		HF-STU-12S-3/4	12	20X1.5	3/4-16	21.8	34.4	11.1	22	24
		HF-STU-14S-7/8	14	22X1.5	7/8-14	26.8	36.3	12.7	27	27
	400	HF-STU-16S-7/8	16	24X1.5	7/8-14	26.8	36.8	12.7	27	30
		HF-STU-20S-1 1/16	20	30X2	1 1/16-12	31.8	42.9	15.1	32	36
		HF-STU-25S-1 5/16	25	36X2	1 5/16-12	40.8	47.9	15.1	41	46
		HF-STU-30S-1 5/8	30	42X2	1 5/8-12	49.8	50.9	15.1	50	50
		HF-STU-38S-1 7/8	38	52X2	1 7/8-12	54.8	59.9	15.1	55	60

Series	W.P (Bar)	Part No.	Ø Tube	m	P	L1	L2	CH1	CH2
L	315	HF-STN-6L-1/8	6	12X1.5	1/8	23	10	14	14
		HF-STN-8L-1/4	8	14X1.5	1/4	27.5	15	14	17
		HF-STN-10L-1/4	10	16X1.5	1/4	25.5	15	19	19
		HF-STN-12L-3/8	12	18X1.5	3/8	31.5	15	22	22
		HF-STN-15L-1/2	15	22X1.5	1/2	29	19.5	27	27
	HF-STN-18L-1/2	18	26X1.5	1/2	28.5	19.5	27	32	
	160	HF-STN-22L-3/4	22	30X2	3/4	29.5	20	32	36
		HF-STN-28L-1	28	36X2	1	32	25	41	41
HF-STN-35L-1 1/4		35	45X2	1 1/4	39.5	25.5	50	50	
S	630	HF-STN-42L-1 1/2	42	52X2	1 1/2	43.5	26	55	60
		HF-STN-6S-1/4	6	14X1.5	1/4	25	15	14	17
		HF-STN-8S-1/4	8	16X1.5	1/4	27.5	15	17	19
		HF-STN-10S-3/8	10	18X1.5	3/8	30	15	17	22
		HF-STN-12S-3/8	12	20X1.5	3/8	32	15	22	24
	400	HF-STN-14S-1/2	14	22X1.5	1/2	33.5	19.5	27	27
		HF-STN-16S-1/2	16	24X1.5	1/2	34	19.5	27	30
		HF-STN-20S-3/4	20	30X2	3/4	40	20	32	36
		HF-STN-25S-1	25	36X2	1	45	25	41	46
		HF-STN-30S-1 1/4	30	42X2	1 1/4	48	25.5	50	50
315	HF-STN-38S-1 1/2	38	52X2	1 1/2	57	26	55	60	

STRAIGHT COUPLING WITH SWIVEL NUT

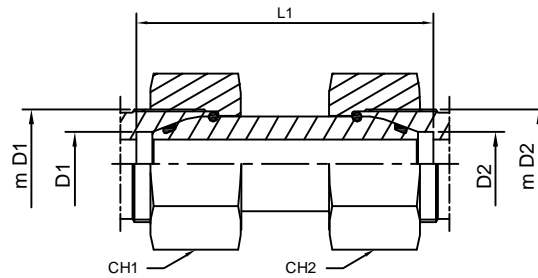

Series	W.P (Bar)	Part No.	Ø Tube		m D1	m D2	L1	CH1	CH2
			D1	D2					
L	315	HF-GZ-6L	6	6	12X1.5	12X1.5	40	14	14
		HF-GZ-8L	8	8	14X1.5	14X1.5	40	17	17
		HF-GZ-10L	10	10	16X1.5	16X1.5	40	19	19
		HF-GZ-12L	12	12	18X1.5	18X1.5	40	22	22
		HF-GZ-15L	15	15	22X1.5	22X1.5	44	27	27
	HF-GZ-18L	18	18	26X1.5	26X1.5	43	32	32	
	HF-GZ-22L	22	22	30X2	30X2	50	36	36	
	HF-GZ-28L	28	28	36X2	36X2	51	41	41	
	HF-GZ-35L	35	35	45X2	45X2	62	50	50	
HF-GZ-42L	42	42	52X2	52X2	62	60	60		
S	630	HF-GZ-6S	6	6	14X1.5	14X1.5	41	17	17
		HF-GZ-8S	8	8	16X1.5	16X1.5	41	19	19
		HF-GZ-10S	10	10	18X1.5	18X1.5	44	22	22
		HF-GZ-12S	12	12	20X1.5	20X1.5	45	24	24
		HF-GZ-14S	14	14	22X1.5	22X1.5	49	27	27
	HF-GZ-16S	16	16	24X1.5	24X1.5	52	30	30	
	HF-GZ-20S	20	20	30X2	30X2	61	36	36	
	HF-GZ-25S	25	25	36X2	36X2	68	46	46	
	HF-GZ-30S	30	30	42X2	42X2	74	50	50	
HF-GZ-38S	38	38	52X2	52X2	83	60	60		
L	315	HF-GZ-8L	8	6	14X1.5	12X1.5	37	17	14
		HF-GZ-10L	10	6	16X1.5	12X1.5	36.5	19	14
		HF-GZ-12L	12	6	18X1.5	12X1.5	36.5	22	14
		HF-GZ-10L	10	8	16X1.5	14X1.5	36.5	19	17
		HF-GZ-12L	12	8	18X1.5	14X1.5	36.5	22	17
		HF-GZ-15L	15	8	22X1.5	14X1.5	40.5	27	17
		HF-GZ-12L	12	10	18X1.5	16X1.5	36	22	19
		HF-GZ-15L	15	10	22X1.5	16X1.5	40	27	19
		HF-GZ-18L	18	10	26X1.5	16X1.5	39.5	32	19
		HF-GZ-15L	15	12	22X1.5	18X1.5	40	27	22
		HF-GZ-18L	18	12	26X1.5	18X1.5	39.5	32	22
		HF-GZ-22L	22	12	30X2	18X1.5	42.5	36	22
		HF-GZ-18L	18	15	26X1.5	22X1.5	43.5	32	27
		HF-GZ-22L	22	15	30X2	22X1.5	46.5	36	27
		HF-GZ-28L	28	15	36X2	22X1.5	47.5	41	27
	160	HF-GZ-22L	22	18	30X2	26X1.5	46	36	32
		HF-GZ-28L	28	18	36X2	26X1.5	47	41	32
		HF-GZ-35L	35	18	45X2	26X1.5	52.5	50	32
		HF-GZ-28L	28	22	36X2	30X2	50	41	36
		HF-GZ-35L	35	22	45X2	30X2	55.5	50	36
		HF-GZ-42L	42	22	52X2	30X2	55.5	60	36
		HF-GZ-35L	35	28	45X2	36X2	56.5	50	41
		HF-GZ-42L	42	28	52X2	36X2	56.5	60	41
		HF-GZ-42L	42	35	52X2	45X2	62	60	50

STRAIGHT COUPLING WITH SWIVEL NUT

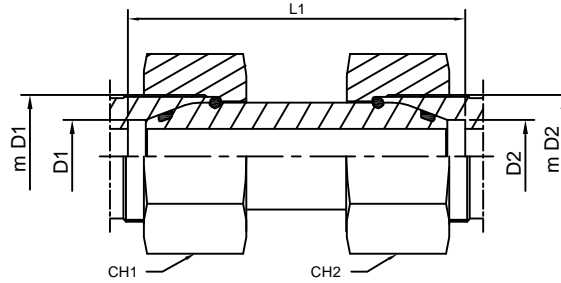

Series	W.P (Bar)	Part No.	Ø Tube		m D1	m D2	L1	CH1	CH2
			D1	D2					
L	630	HF-G2-8L/6L	8	6	16X1.5	14X1.5	37	19	17
		HF-G2-8L/6L	10	6	18X1.5	14X1.5	38	22	17
		HF-G2-12L/6L	12	6	20X1.5	14X1.5	39	24	17
		HF-G2-10L/8L	10	8	18X1.5	16X1.5	38	22	19
		HF-G2-12L/8L	12	8	20X1.5	16X1.5	39	24	19
	400	HF-G2-12L/10L	12	10	20X1.5	18X1.5	40	24	22
		HF-G2-16L/10L	16	10	24X1.5	18X1.5	44	30	22
		HF-G2-16L/12L	16	12	24X1.5	20X1.5	45	30	24
		HF-G2-20L/12L	20	12	30X2	20X1.5	48.5	36	24
		HF-G2-20L/16L	20	16	30X2	24X1.5	52.5	36	30
		HF-G2-25L/16L	25	16	36X2	24X1.5	56	46	30
		HF-G2-30L/16L	30	16	42X2	24X1.5	58.5	50	30
		HF-G2-25L/20L	25	20	36X2	30X2	59.5	46	36
		HF-G2-30L/20L	30	20	42X2	30X2	62	50	36
315		HF-G2-38L/20L	38	20	52X2	30X2	64	60	36
400	HF-G2-30L/25L	30	25	42X2	36X2	65.5	50	46	
315	HF-G2-38L/25L	38	25	52X2	36X2	67.5	60	46	
	HF-G2-38L/30L	38	30	52X2	42X2	70	60	50	
S/L	315	HF-G2-6S/6S	6	6	14X1.5	12X1.5	37	17	14
		HF-G2-8S/8S	8	8	16X1.5	14X1.5	37	19	17
		HF-G2-10S/10S	10	10	18X1.5	16X1.5	37.5	22	19
		HF-G2-12S/12S	12	12	20X1.5	18X1.5	38.5	24	22
		HF-G2-16S/15S	16	15	24X1.5	22X1.5	46.5	30	27
		HF-G2-18S/16S	18	16	26X1.5	24X1.5	46	32	30
L/S		HF-G2-20S/18S	20	18	30X2	26X1.5	49.5	36	32
L/S	160	HF-G2-22S/20S	22	20	30X2	30X2	52.5	36	36
S/L		HF-G2-25S/22S	25	22	36X2	30X2	56	46	36
L/S		HF-G2-28S/25S	28	25	36X2	36X2	57	41	46
S/L		HF-G2-30S/28S	30	28	42X2	36X2	59.5	50	41
L/S		HF-G2-35S/30S	35	30	45X2	42X2	65	50	50
S/L		HF-G2-38S/35S	38	35	52X2	45X2	67	60	50
L/S		HF-G2-42S/38S	42	38	52X2	52X2	67	60	60

ADJUSTABLE MALE STUD ELBOW

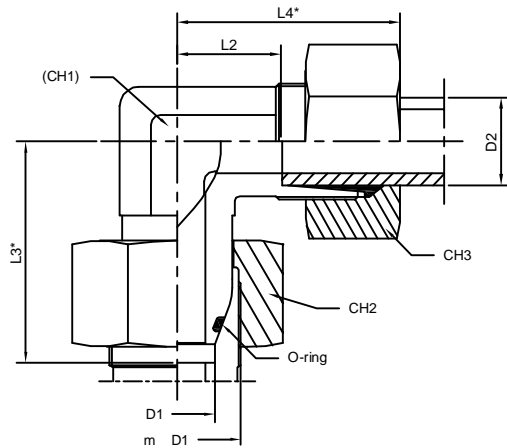
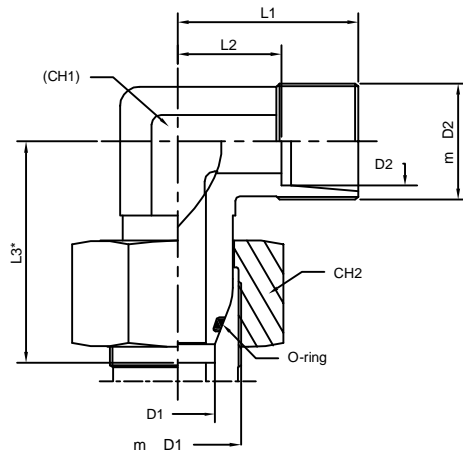

Series	W.P (Bar)	Part No.	Ø Tube		m D1	m D2	L1	L2	L3*	L4*	CH1	CH2	CH3
			D1	D2									
L	500	HF-SE-6L	6	6	12X1.5	12X1.5	19	12	26	27	12	14	14
		HF-SE-8L	8	8	14X1.5	14X1.5	21	14	27.5	29	12	17	17
		HF-SE-10L	10	10	16X1.5	16X1.5	22	15	29	30	14	19	19
	400	HF-SE-12L	12	12	18X1.5	18X1.5	24	17	29.5	32	17	22	22
		HF-SE-15L	15	15	22X1.5	22X1.5	28	21	32.5	36	19	27	27
	315	HF-SE-18L	18	18	26X1.5	26X1.5	31	23.5	35.5	40	24	32	32
	250	HF-SE-22L	22	22	30X2	30X2	35	27.5	38.5	44	27	36	36
		HF-SE-28L	28	28	36X2	36X2	38	30.5	41.5	47	36	41	41
HF-SE-35L		35	35	45X2	45X2	45	34.5	51.5	56	41	50	50	
HF-SE-42L		42	42	52X2	52X2	51	40	56	63	50	60	60	
S	800	HF-SE-6S	6	6	14X1.5	14X1.5	23	16	27	31	12	17	17
		HF-SE-8S	8	8	16X1.5	16X1.5	24	17	27.5	32	14	19	19
		HF-SE-10S	10	10	18X1.5	18X1.5	25	17.5	30.5	34	17	22	22
	630	HF-SE-12S	12	12	20X1.5	20X1.5	29	21.5	31.5	38	17	24	24
		HF-SE-14S	14	14	22X1.5	22X1.5	30	22	35	40	19	27	27
	420	HF-SE-16S	16	16	24X1.5	24X1.5	33	24.5	36.5	43	24	30	30
		HF-SE-20S	20	20	30X2	30X2	37	26.5	44.5	48	27	36	36
		HF-SE-25S	25	25	36X2	36X2	42	30	50	54	36	46	46
315	HF-SE-30S	30	30	42X2	42X2	49	35.5	55.5	62	41	50	50	
	HF-SE-38S	38	38	52X2	52X2	57	41	63	72	50	60	60	
	HF-SE-42S	42	42	52X2	52X2	57	41	63	72	50	60	60	
S/L	315	HF-SE-6S/L	6S	6S	14X1.5	12X1.5	19	12	27	27	12	17	14
		HF-SE-8S/L	8S	8S	16X1.5	14X1.5	21	14	27.5	29	14	19	17
		HF-SE-10S/L	10S	10S	18X1.5	16X1.5	24	17	30	32	17	22	19
L/S	315	HF-SE-12S/L	12S	12S	20X1.5	18X1.5	24	17	31	32	17	24	22
		HF-SE-6L/S	6L	6L	12X1.5	14X1.5	23	16	26	31	12	14	17
		HF-SE-8L/S	8L	8L	14X1.5	16X1.5	24	17	27.5	32	14	17	19
		HF-SE-10L/S	10L	10L	16X1.5	18X1.5	25	17.5	29.5	34	17	19	22
		HF-SE-12L/S	12L	12L	18X1.5	20X1.5	29	21.5	30	38	17	22	24

ADJUSTABLE ELBOW WITH MALE STUD COUPLING

Thread BSP Parallel - Thread Metric Parallel

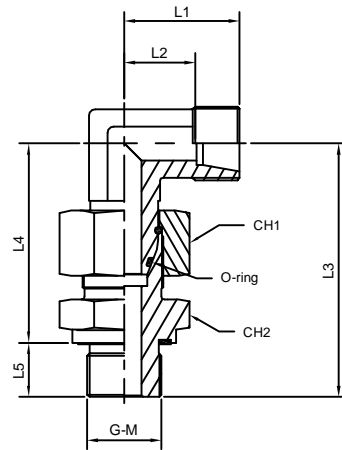
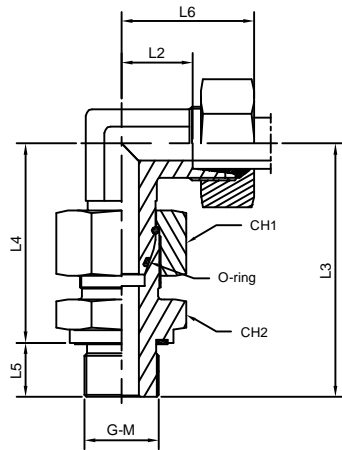

Series	W.P (Bar)	Part No.	Ø Tube	G	L1	L2	L3	L4	L5	L6	CH1	CH2
L	315	HF-SEB-1/8L	6	1/8	19	12	42.5	34.5	8	27	14	14
		HF-SEB-1/4L	8	1/4	21	14	49.5	37.5	12	29	17	19
		HF-SEB-1/4L	10	1/4	22	15	52	40	12	30	19	19
		HF-SEB-3/8L	12	3/8	24	17	54	42	12	32	22	22
	HF-SEB-1/2L	15	1/2	28	21	60.5	46.5	14	36	27	27	
	HF-SEB-1/2L	18	1/2	31	23.5	64	50	14	40	32	27	
	HF-SEB-3/4L	22	3/4	35	27.5	71	55	16	44	36	32	
	HF-SEB-1L	28	1	38	30.5	77	59	18	47	41	41	
S	630	HF-SEB-1/4S	6	1/4	23	16	52	40	12	31	17	19
		HF-SEB-1/4S	8	1/4	24	17	54.5	42.5	12	32	19	19
		HF-SEB-3/8S	10	3/8	25	17.5	57.5	45.5	12	34	22	22
		HF-SEB-3/8S	12	3/8	29	21.5	60.5	48.5	12	38	24	22
	HF-SEB-1/2S	14	1/2	30	22	68	54	14	40	27	27	
	HF-SEB-1/2S	16	1/2	33	24.5	69	55	14	43	30	27	
	HF-SEB-3/4S	20	3/4	37	26.5	81	65	16	48	36	32	
	HF-SEB-1S	25	1	42	30	91	73	18	54	46	41	
315	HF-SEB-1 1/4S	30	1 1/4	49	35.5	99	79	20	62	50	50	
	HF-SEB-1 1/2S	38	1 1/2	57	41	111	89	22	72	60	55	

Series	W.P (Bar)	Part No.	Ø Tube	M	L1	L2	L3	L4	L5	L6	CH1	CH2
L	315	HF-SEM-10X1	6	10X1	19	12	42.5	34.5	8	27	14	14
		HF-SEM-10X1	8	12X1.5	21	14	49.5	37.5	12	29	17	19
		HF-SEM-10X1	10	14X1.5	22	15	52	40	12	30	19	19
		HF-SEM-10X1	12	16X1.5	24	17	54	42	12	32	22	22
	HF-SEM-10X1	15	18X1.5	28	21	60.5	46.5	14	36	27	27	
	HF-SEM-10X1	18	22X1.5	31	23.5	64	50	14	40	32	27	
	HF-SEM-10X1	22	27X2	35	27.5	71	55	16	44	36	32	
	HF-SEM-10X1	28	33X2	38	30.5	77	59	18	47	41	41	
S	630	HF-SEM-10X1	35	42X2	45	34.5	89	69	20	56	50	50
		HF-SEM-10X1	42	48X2	51	40	97	75	22	63	60	55
		HF-SEM-10X1	6	12X1.5	23	16	52	40	12	31	17	19
		HF-SEM-10X1	8	14X1.5	24	17	54.5	42.5	12	32	19	19
	HF-SEM-10X1	10	16X1.5	25	17.5	57.5	45.5	12	34	22	22	
	HF-SEM-10X1	12	18X1.5	29	21.5	60.5	48.5	12	38	24	22	
	HF-SEM-10X1	14	20X1.5	30	22	68	54	14	40	27	27	
	HF-SEM-10X1	16	22X1.5	33	24.5	69	55	14	43	30	27	
400	HF-SEM-10X1	20	27X2	37	26.5	81	65	16	48	36	32	
	HF-SEM-10X1	25	33X2	42	30	91	73	18	54	46	41	
	HF-SEM-10X1	30	42X2	49	35.5	99	79	20	62	50	50	
315	HF-SEM-10X1	38	48X2	57	41	111	89	22	72	60	55	

ADJUSTABLE BARREL TEE

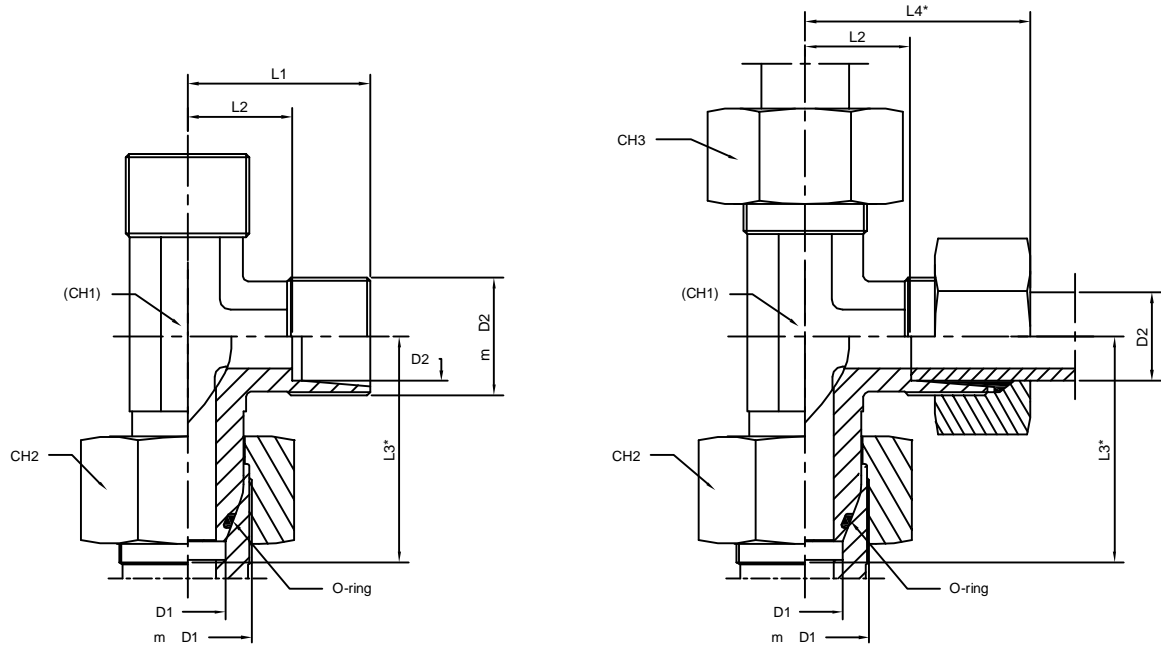

Series	W.P (Bar)	Part No.	Ø Tube		m D1	m D2	L1	L2	L3*	L4*	CH1	CH2	CH3
			D1	D2									
L	500	HF-TER-6L	6	6	12X1.5	12X1.5	19	12	26	27	12	14	14
		HF-TER-8L	8	8	14X1.5	14X1.5	21	14	27.5	29	12	17	17
		HF-TER-10L	10	10	16X1.5	16X1.5	22	15	29	30	14	19	19
	400	HF-TER-12L	12	12	18X1.5	18X1.5	24	17	29.5	32	17	22	22
		HF-TER-15L	15	15	22X1.5	22X1.5	28	21	32.5	36	19	27	27
		HF-TER-18L	18	18	26X1.5	26X1.5	31	23.5	35.5	40	24	32	32
	250	HF-TER-22L	22	22	30X2	30X2	35	27.5	38.5	44	27	36	36
		HF-TER-28L	28	28	36X2	36X2	38	30.5	41.5	47	36	41	41
		HF-TER-35L	35	35	45X2	45X2	45	34.5	51.5	56	41	50	50
HF-TER-42L		42	42	52X2	52X2	51	40	56	63	50	60	60	
S	800	HF-TER-6S	6	6	14X1.5	14X1.5	23	16	27	31	12	17	17
		HF-TER-8S	8	8	16X1.5	16X1.5	24	17	27.5	32	14	19	19
		HF-TER-10S	10	10	18X1.5	18X1.5	25	17.5	30.5	34	17	22	22
	630	HF-TER-12S	12	12	20X1.5	20X1.5	29	21.5	31.5	38	17	24	24
		HF-TER-14S	14	14	22X1.5	22X1.5	30	22	35	40	19	27	27
		HF-TER-16S	16	16	24X1.5	24X1.5	33	24.5	36.5	43	24	30	30
	420	HF-TER-20S	20	20	30X2	30X2	37	26.5	44.5	48	27	36	36
		HF-TER-25S	25	25	36X2	36X2	42	30	50	54	36	46	46
		HF-TER-30S	30	30	42X2	42X2	49	35.5	55.5	62	41	50	50
		HF-TER-38S	38	38	52X2	52X2	57	41	63	72	50	60	60
S/L	315	HF-TER-6S/L	6S	6S	14X1.5	12X1.5	19	12	27	27	12	17	14
		HF-TER-8S/L	8S	8S	16X1.5	14X1.5	21	14	27.5	29	14	19	17
		HF-TER-10S/L	10S	10S	18X1.5	16X1.5	24	17	30	32	17	22	19
		HF-TER-12S/L	12S	12S	20X1.5	18X1.5	24	17	31	32	17	24	22
L/S	315	HF-TER-6L/S	6L	6L	12X1.5	14X1.5	23	16	26	31	12	14	17
		HF-TER-8L/S	8L	8L	14X1.5	16X1.5	24	17	27.5	32	14	17	19
		HF-TER-10L/S	10L	10L	16X1.5	18X1.5	25	17.5	29.5	34	17	19	22
		HF-TER-12L/S	12L	12L	18X1.5	20X1.5	29	21.5	30	38	17	22	24

ADJUSTABLE BARREL TEE WITH MALE STUD CONNECTOR

Thread BSP Parallel - Thread Metric Parallel

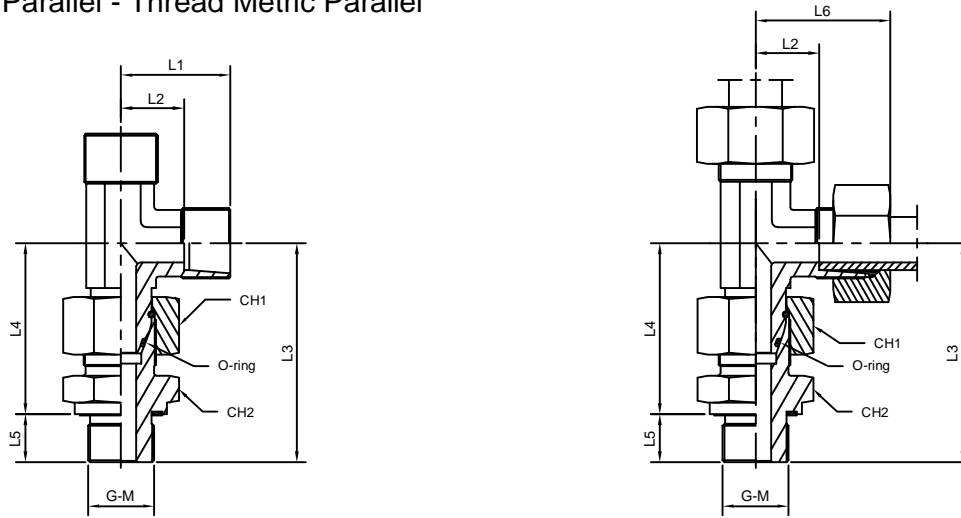

Series	W.P (Bar)	Part No.	Ø Tube	G	L1	L2	L3	L4	L5	L6	CH1	CH2
L	315	HF-TER-6L-1/8 ED	6	1/8	19	12	42.5	34.5	8	27	14	14
		HF-TER-8L-1/4 ED	8	1/4	21	14	49.5	37.5	12	29	17	19
		HF-TER-10L-1/4 ED	10	1/4	22	15	52	40	12	30	19	19
		HF-TER-12L-3/8 ED	12	3/8	24	17	54	42	12	32	22	22
	160	HF-TER-15L-1/2 ED	15	1/2	28	21	60.5	46.5	14	36	27	27
		HF-TER-18L-1/2 ED	18	1/2	31	23.5	64	50	14	40	32	27
		HF-TER-22L-3/4 ED	22	3/4	35	27.5	71	55	16	44	36	32
		HF-TER-28L-1 ED	28	1	38	30.5	77	59	18	47	41	41
S	630	HF-TER-35L-1 1/4 ED	35	1 1/4	45	34.5	89	69	20	56	50	50
		HF-TER-42L-1 1/2 ED	42	1 1/2	51	40	97	75	22	63	60	55
		HF-TER-6S-1/4 ED	6	1/4	23	16	52	40	12	31	17	19
		HF-TER-8S-1/4 ED	8	1/4	24	17	54.5	42.5	12	32	19	19
	400	HF-TER-10S-3/8 ED	10	3/8	25	17.5	57.5	45.5	12	34	22	22
		HF-TER-12S-3/8 ED	12	3/8	29	21.5	60.5	48.5	12	38	24	22
		HF-TER-14S-1/2 ED	14	1/2	30	22	68	54	14	40	27	27
		HF-TER-16S-1/2 ED	16	1/2	33	24.5	69	55	14	43	30	27
315	HF-TER-20S-3/4 ED	20	3/4	37	26.5	81	65	16	48	36	32	
	HF-TER-25S-1 ED	25	1	42	30	91	73	18	54	46	41	
		HF-TER-30S-1 1/4 ED	30	1 1/4	49	35.5	99	79	20	62	50	50
		HF-TER-38S-1 1/2 ED	38	1 1/2	57	41	111	89	22	72	60	55

Series	W.P (Bar)	Part No.	Ø Tube	M	L1	L2	L3	L4	L5	L6	CH1	CH2
L	315	HF-TERM-6L-10X1 ED	6	10X1	19	34.5	42.5	34.5	8	27	14	14
		HF-TERM-8L-12X1.5 ED	8	12X1.5	21	37	49.5	37.5	12	29	17	19
		HF-TERM-10L-14X1.5 ED	10	14X1.5	22	39.5	52	40	12	30	19	19
		HF-TERM-12L-16X1.5 ED	12	16X1.5	24	41.5	54	42	12	32	22	22
	160	HF-TERM-15L-18X1.5 ED	15	18X1.5	28	45.5	60.5	46.5	14	36	27	27
		HF-TERM-18L-22X1.5 ED	18	22X1.5	31	49.5	64	50	14	40	32	27
		HF-TERM-22L-27X2 ED	22	27X2	35	54.5	71	55	16	44	36	32
		HF-TERM-28L-33X2 ED	28	33X2	38	59	77	59	18	47	41	41
S	630	HF-TERM-35L-42X2 ED	35	42X2	45	68.5	89	69	20	56	50	50
		HF-TERM-42L-48X2 ED	42	48X2	51	75	97	75	22	63	60	55
		HF-TERM-6S-12X1.5 ED	6	12X1.5	23	40	52	40	12	31	17	19
		HF-TERM-8S-14X1.5 ED	8	14X1.5	24	42	54.5	42.5	12	32	19	19
	400	HF-TERM-10S-16X1.5 ED	10	16X1.5	25	44.5	57.5	45.5	12	34	22	22
		HF-TERM-12S-18X1.5 ED	12	18X1.5	29	47.5	60.5	48.5	12	38	24	22
		HF-TERM-14S-20X1.5 ED	14	20X1.5	30	53.5	68	54	14	40	27	27
		HF-TERM-16S-22X1.5 ED	16	22X1.5	33	54.5	69	55	14	43	30	27
315	HF-TERM-20S-27X2 ED	20	27X2	37	64.5	81	65	16	48	36	32	
	HF-TERM-25S-33X2 ED	25	33X2	42	72.5	91	73	18	54	46	41	
		HF-TERM-30S-42X2 ED	30	42X2	49	78.5	99	79	20	62	50	50
		HF-TERM-38S-48X2 ED	38	48X2	57	89	111	89	22	72	60	55

ADJUSTABLE BRANCH TEE

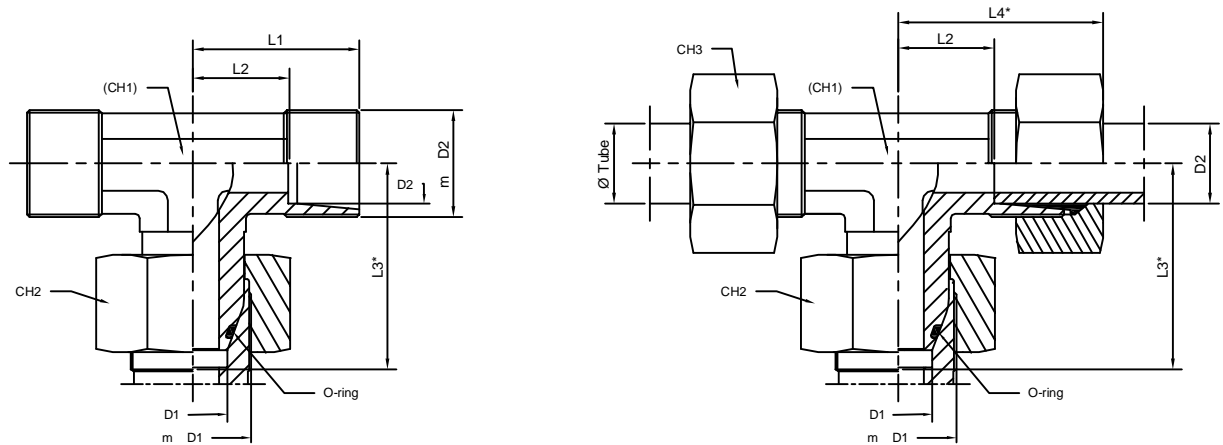

Series	W.P. (Bar)	Part No.	Ø Tube		m D1	m D2	L1	L2	L3*	L4*	CH1	CH2	CH3
			D1	D2									
L	500	HF-TEB-6L	6	6	12X1.5	12X1.5	19	12	26	27	12	14	14
		HF-TEB-8L	8	8	14X1.5	14X1.5	21	14	27.5	29	12	17	17
		HF-TEB-10L	10	10	16X1.5	16X1.5	22	15	29	30	14	19	19
	400	HF-TEB-12L	12	12	18X1.5	18X1.5	24	17	29.5	32	17	22	22
		HF-TEB-15L	15	15	22X1.5	22X1.5	28	21	32.5	36	19	27	27
		HF-TEB-18L	18	18	26X1.5	26X1.5	31	23.5	35.5	40	24	32	32
	250	HF-TEB-22L	22	22	30X2	30X2	35	27.5	38.5	44	27	36	36
		HF-TEB-28L	28	28	36X2	36X2	38	30.5	41.5	47	36	41	41
		HF-TEB-35L	35	35	45X2	45X2	45	34.5	51.5	56	41	50	50
		HF-TEB-42L	42	42	52X2	52X2	51	40	56	63	50	60	60
S	800	HF-TEB-6S	6	6	14X1.5	14X1.5	23	16	27	31	12	17	17
		HF-TEB-8S	8	8	16X1.5	16X1.5	24	17	27.5	32	14	19	19
		HF-TEB-10S	10	10	18X1.5	18X1.5	25	17.5	30.5	34	17	22	22
	630	HF-TEB-12S	12	12	20X1.5	20X1.5	29	21.5	31.5	38	17	24	24
		HF-TEB-14S	14	14	22X1.5	22X1.5	30	22	35	40	19	27	27
		HF-TEB-16S	16	16	24X1.5	24X1.5	33	24.5	36.5	43	24	30	30
	420	HF-TEB-20S	20	20	30X2	30X2	37	26.5	44.5	48	27	36	36
		HF-TEB-25S	25	25	36X2	36X2	42	30	50	54	36	46	46
		HF-TEB-30S	30	30	42X2	42X2	49	35.5	55.5	62	41	50	50
		HF-TEB-38S	38	38	52X2	52X2	57	41	63	72	50	60	60
S/L	315	HF-TEB-6S/L	6S	6S	14X1.5	12X1.5	19	12	27	27	12	17	14
		HF-TEB-8S/L	8S	8S	16X1.5	14X1.5	21	14	27.5	29	14	19	17
		HF-TEB-10S/L	10S	10S	18X1.5	16X1.5	24	17	30	32	17	22	19
		HF-TEB-12S/L	12S	12S	20X1.5	18X1.5	24	17	31	32	17	24	22
L/S	315	HF-TEB-6L/S	6L	6L	12X1.5	14X1.5	23	16	26	31	12	14	17
		HF-TEB-8L/S	8L	8L	14X1.5	16X1.5	24	17	27.5	32	14	17	19
		HF-TEB-10L/S	10L	10L	16X1.5	18X1.5	25	17.5	29.5	34	17	19	22
		HF-TEB-12L/S	12L	12L	18X1.5	20X1.5	29	21.5	30	38	17	22	24

ADJUSTABLE BRANCH TEE WITH MALE STUD COUPLING

Thread BSP Parallel - Thread Metric Parallel

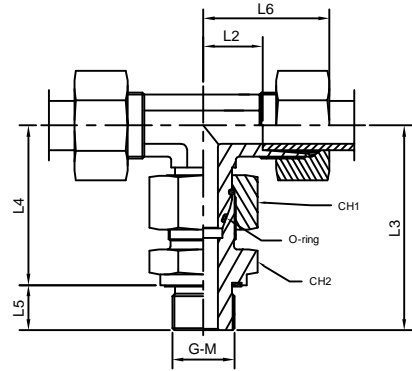
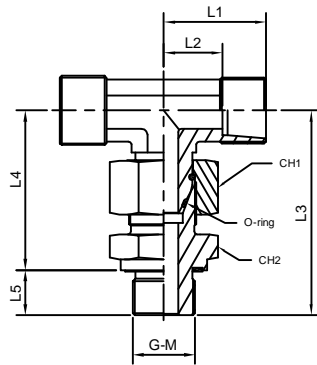

Series	W.P (Bar)	Part No.	Ø Tube	G	L1	L2	L3	L4	L5	L6	CH1	CH2
L	315	HF-TEB-6L-1/8 ED	6	1/8	19	12	42.5	34.5	8	27	14	14
		HF-TEB-8L-1/4 ED	8	1/4	21	14	49.5	37.5	12	29	17	19
		HF-TEB-10L-1/4 ED	10	1/4	22	15	52	40	12	30	19	19
		HF-TEB-12L-3/8 ED	12	3/8	24	17	54	42	12	32	22	22
		HF-TEB-15L-1/2 ED	15	1/2	28	21	60.5	46.5	14	36	27	27
	HF-TEB-18L-1/2 ED	18	1/2	31	23.5	64	50	14	40	32	27	
	160	HF-TEB-22L-3/4 ED	22	3/4	35	27.5	71	55	16	44	36	32
		HF-TEB-28L-1 ED	28	1	38	30.5	77	59	18	47	41	41
HF-TEB-35L-1 1/4 ED		35	1 1/4	45	34.5	89	69	20	56	50	50	
		HF-TEB-42L-1 1/2 ED	42	1 1/2	51	40	97	75	22	63	60	55
S	630	HF-TEB-6S-1/4 ED	6	1/4	23	16	52	40	12	31	17	19
		HF-TEB-8S-1/4 ED	8	1/4	24	17	54.5	42.5	12	32	19	19
		HF-TEB-10S-3/8 ED	10	3/8	25	17.5	57.5	45.5	12	34	22	22
		HF-TEB-12S-3/8 ED	12	3/8	29	21.5	60.5	48.5	12	38	24	22
		HF-TEB-14S-1/2 ED	14	1/2	30	22	68	54	14	40	27	27
	400	HF-TEB-16S-1/2 ED	16	1/2	33	24.5	69	55	14	43	30	27
		HF-TEB-20S-3/4 ED	20	3/4	37	26.5	81	65	16	48	36	32
		HF-TEB-25S-1 ED	25	1	42	30	91	73	18	54	46	41
		HF-TEB-30S-1 1/4 ED	30	1 1/4	49	35.5	99	79	20	62	50	50
		HF-TEB-38S-1 1/2 ED	38	1 1/2	57	41	111	89	22	72	60	55

Series	W.P (Bar)	Part No.	Ø Tube	G	L1	L2	L3	L4	L5	L6	CH1	CH2
L	315	HF-TEBM-6L-10X1 ED	6	10X1	19	12	42.5	34.5	8	27	14	14
		HF-TEBM-8L-12X1.5 ED	8	12X1.5	21	14	49.5	37.5	12	29	17	19
		HF-TEBM-10L-14X1.5 ED	10	14X1.5	22	15	52	40	12	30	19	19
		HF-TEBM-12L-16X1.5 ED	12	16X1.5	24	17	54	42	12	32	22	22
		HF-TEBM-15L-18X1.5 ED	15	18X1.5	28	21	60.5	46.5	14	36	27	27
	HF-TEBM-18L-18X1.5 ED	18	22X1.5	31	23.5	64	50	14	40	32	27	
	160	HF-TEBM-22L-27X2 ED	22	27X2	35	27.5	71	55	16	44	36	32
		HF-TEBM-28L-33X2 ED	28	33X2	38	30.5	77	59	18	47	41	41
HF-TEBM-35L-42X2 ED		35	42X2	45	34.5	89	69	20	56	50	50	
		HF-TEBM-42L-48X2 ED	42	48X2	51	40	97	75	22	63	60	55
S	630	HF-TEBM-6S-12X1.5 ED	6	12X1.5	23	16	52	40	12	31	17	19
		HF-TEBM-8S-14X1.5 ED	8	14X1.5	24	17	54.5	42.5	12	32	19	19
		HF-TEBM-10S-10X1.5 ED	10	16X1.5	25	17.5	57.5	45.5	12	34	22	22
		HF-TEBM-12S-18X1.5 ED	12	18X1.5	29	21.5	60.5	48.5	12	38	24	22
		HF-TEBM-14S-20X1.5 ED	14	20X1.5	30	22	68	54	14	40	27	27
	400	HF-TEBM-16S-22X1.5 ED	16	22X1.5	33	24.5	69	55	14	43	30	27
		HF-TEBM-20S-27X2 ED	20	27X2	37	26.5	81	65	16	48	36	32
		HF-TEBM-25S-33X2 ED	25	33X2	42	30	91	73	18	54	46	41
		HF-TEBM-30S-42X2 ED	30	42X2	49	35.5	99	79	20	62	50	50
		HF-TEBM-38S-48X2 ED	38	48X2	57	41	111	89	22	72	60	55

REDUCING TUBE ADAPTER WITH SWIVEL NUT L SERIES

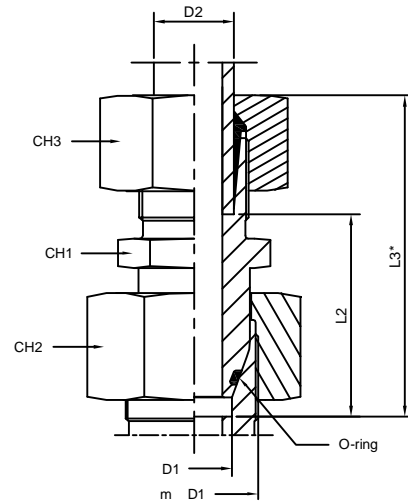
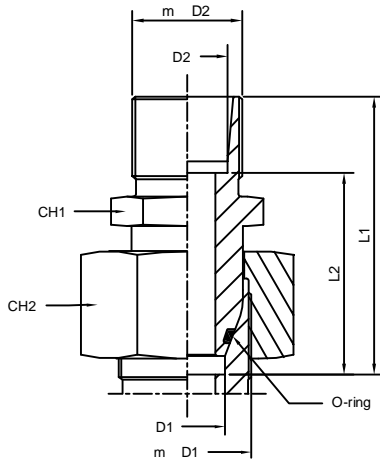

Series	W.P (Bar)	Part No.	Ø Tube		m D1	m D2	L1	L2	L3*	CH1	CH2	CH3
			D1	D2								
L	500	HF-KOR-8L/6L	8	6	14X1.5	12X1.5	31	24	39	12	17	14
		HF-KOR-10L/6L	10	6	16X1.5	12X1.5	32.5	25.5	40.5	14	19	14
	400	HF-KOR-12L/6L	12	6	18X1.5	12X1.5	32.5	25.5	40.5	17	22	14
		HF-KOR-15L/6L	15	6	22X1.5	12X1.5	35.5	28.5	43.5	19	27	14
	250	HF-KOR-18L/6L	18	6	26X1.5	12X1.5	36.5	29.5	44.5	24	32	14
		HF-KOR-22L/6L	22	6	30X2	12X1.5	38.5	31.5	46.5	27	36	14
		HF-KOR-28L/6L	28	6	36X2	12X1.5	39.5	32.5	47.5	32	41	14
	160	HF-KOR-35L/6L	35	6	45X2	12X1.5	45	38	53	41	50	14
	160	HF-KOR-42L/6L	42	6	52X2	12X1.5	46	39	54	50	60	14
	500	HF-KOR-10L/8L	10	8	16X1.5	14X1.5	32.5	25.5	40.5	14	19	17
		HF-KOR-12L/8L	12	8	18X1.5	14X1.5	32.5	25.5	40.5	17	22	17
	400	HF-KOR-15L/8L	15	8	22X1.5	14X1.5	35.5	28.5	43.5	19	27	17
		HF-KOR-18L/8L	18	8	26X1.5	14X1.5	36.5	29.5	44.5	24	32	17
		HF-KOR-22L/8L	22	8	30X2	14X1.5	38.5	31.5	46.5	27	36	17
	250	HF-KOR-28L/8L	28	8	36X2	14X1.5	39.5	32.5	47.5	32	41	17
		HF-KOR-35L/8L	35	8	45X2	14X1.5	45	38	53	41	50	17
		HF-KOR-42L/8L	42	8	52X2	14X1.5	46	39	54	50	60	17
	400	HF-KOR-12L/10L	12	10	18X1.5	16X1.5	33.5	26.5	41.5	17	22	19
		HF-KOR-15L/10L	15	10	22X1.5	16X1.5	36.5	29.5	44.5	19	27	19
		HF-KOR-18L/10L	18	10	26X1.5	16X1.5	37.5	30.5	45.5	24	32	19
	250	HF-KOR-22L/10L	22	10	30X2	16X1.5	39.5	32.5	47.5	27	36	19
		HF-KOR-28L/10L	28	10	36X2	16X1.5	40.5	33.5	48.5	32	41	19
		HF-KOR-35L/10L	35	10	45X2	16X1.5	46	39	54	41	50	19
	160	HF-KOR-42L/10L	42	10	52X2	16X1.5	47	40	55	50	60	19
	400	HF-KOR-15L/12L	15	12	22X1.5	18X1.5	36.5	29.5	44.5	19	27	22
		HF-KOR-18L/12L	18	12	26X1.5	18X1.5	37.5	30.5	45.5	24	32	22
		HF-KOR-22L/12L	22	12	30X2	18X1.5	39.5	32.5	47.5	27	36	22
	250	HF-KOR-28L/12L	28	12	36X2	18X1.5	40.5	33.5	48.5	32	41	22
		HF-KOR-35L/12L	35	12	45X2	18X1.5	46	39	54	41	50	22
		HF-KOR-42L/12L	42	12	52X2	18X1.5	47	40	55	50	60	22
	400	HF-KOR-18L/15L	18	15	26X1.5	22X1.5	38.5	31.5	46.5	24	32	27
	250	HF-KOR-22L/15L	22	15	30X2	22X1.5	39.5	32.5	47.5	27	36	27
		HF-KOR-28L/15L	28	15	36X2	22X1.5	41.5	34.5	49.5	32	41	27
		HF-KOR-35L/15L	35	15	45X2	22X1.5	47	40	55	41	50	27
	160	HF-KOR-42L/15L	42	15	52X2	22X1.5	48	41	56	50	60	27
	250	HF-KOR-22L/18L	22	18	30X2	22X1.5	40.5	33	49.5	27	36	32
		HF-KOR-28L/18L	28	18	36X2	22X1.5	41.5	34	50.5	32	41	32
		HF-KOR-35L/18L	35	18	45X2	22X1.5	47	39.5	56	41	50	32
	160	HF-KOR-42L/18L	42	18	52X2	22X1.5	48	40.5	57	50	60	32
	250	HF-KOR-28L/22L	28	22	36X2	30X2	43.5	36	52.5	32	41	36
HF-KOR-35L/22L		35	22	45X2	30X2	49	41.5	58	41	50	36	
160	HF-KOR-42L/22L	42	22	52X2	30X2	50	42.5	59	50	60	36	
250	HF-KOR-35L/28L	35	28	45X2	36X2	49	41.5	58	41	50	41	
160	HF-KOR-42L/28L	42	28	52X2	36X2	50	42.5	59	50	60	41	
	HF-KOR-42L/35L	42	35	52X2	45X2	52	41.5	63	50	60	50	

REDUCING TUBE ADAPTER WITH SWIVEL NUT S SERIES

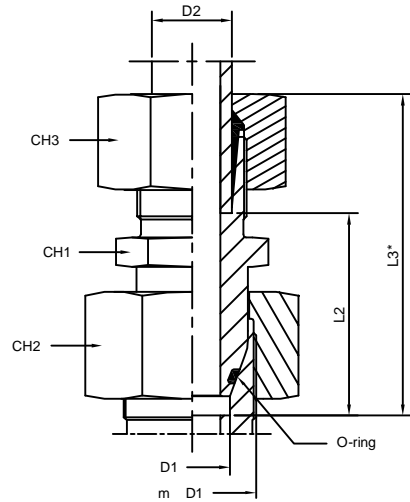
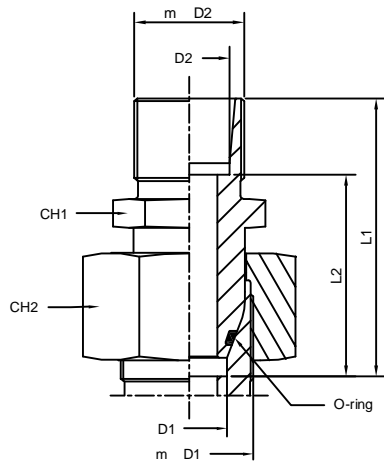

Series	W.P (Bar)	Part No.	Ø Tube D2	D1	m D1	m D2	L1	L2	L3*	CH1	CH2	CH3
S	800	HF-KOR-8S/6S	8	6	16x1.6	14x1.5	34	27	44	14	19	17
		HF-KOR-10S/6S	10	6	18x1.5	14x1.5	34.5	27.5	47	17	22	17
	630	HF-KOR-12S/6S	12	6	20x1.5	14x1.5	36	29	46.5	17	24	17
		HF-KOR-14S/6S	14	6	22x1.5	14x1.5	38.5	31.5	49	19	27	17
	420	HF-KOR-16S/6S	16	6	24x1.5	14x1.5	39	32	53.5	22	30	17
		HF-KOR-20S/6S	20	6	30x2	14x1.5	43	36	56	27	36	17
		HF-KOR-25S/6S	25	6	36x2	14x1.5	45.5	38.5	60.5	32	46	17
	800	HF-KOR-30S/6S	30	6	42x2	14x1.5	51	44	65	41	50	17
		HF-KOR-38S/6S	38	6	52x2	14x1.5	54	47	67	50	60	17
		HF-KOR-10S/8S	10	8	18x1.5	16x1.5	34.5	27.5	46.5	17	22	19
	630	HF-KOR-12S/8S	12	8	20x1.5	16x1.5	36	29	46.5	17	24	19
		HF-KOR-14S/8S	14	8	22x1.5	16x1.5	38.5	31.5	49	19	27	19
		HF-KOR-16S/8S	16	8	24x1.5	16x1.5	39	32	53.5	22	30	19
	420	HF-KOR-20S/8S	20	8	30x2	16x1.5	43	36	56	27	36	19
		HF-KOR-25S/8S	25	8	36x2	16x1.5	45.5	38.5	60.5	32	46	19
		HF-KOR-30S/8S	30	8	42x2	16x1.5	51	44	65	41	50	19
		HF-KOR-38S/8S	38	8	52x2	16x1.5	54	47	67	50	60	19
	630	HF-KOR-12S/10S	12	10	20x1.5	18x1.5	37	29.5	47.5	17	24	22
		HF-KOR-14S/10S	14	10	22x1.5	18x1.5	38.5	31	50	19	27	22
		HF-KOR-16S/10S	16	10	24x1.5	18x1.5	39	31.5	54.5	22	30	22
	420	HF-KOR-20S/10S	20	10	30x2	18x1.5	43	35.5	57	27	36	22
		HF-KOR-25S/10S	25	10	36x2	18x1.5	45.5	38	61.5	32	46	22
		HF-KOR-30S/10S	30	10	42x2	18x1.5	51	43.5	66	41	50	22
		HF-KOR-38S/10S	38	10	52x2	18x1.5	54.5	47	68	50	60	22
	630	HF-KOR-14S/12S	14	12	22x1.5	20x1.5	38.5	31	52	19	27	24
		HF-KOR-16S/12S	16	12	24x1.5	20x1.5	39	31.5	54.5	22	30	24
		HF-KOR-20S/12S	20	12	30x2	20x1.5	43	35.5	57	27	36	24
	420	HF-KOR-25S/12S	25	12	36x2	20x1.5	45.5	38	61.5	32	46	24
		HF-KOR-30S/12S	30	12	42x2	20x1.5	51	43.5	66	41	50	24
		HF-KOR-38S/12S	38	12	52x2	20x1.5	54.5	47	68	50	60	24
HF-KOR-16S/14S		16	14	24x1.5	22x1.5	41	33	57.5	22	30	27	
420	HF-KOR-20S/14S	20	14	30x2	22x1.5	45	37	60	27	36	27	
	HF-KOR-25S/14S	25	14	36x2	22x1.5	47.5	39.5	64.5	32	46	27	
	HF-KOR-30S/14S	30	14	42x2	22x1.5	53	45	69	41	50	27	
	HF-KOR-38S/14S	38	14	52x2	22x1.5	56	48	71	50	60	27	
	HF-KOR-20S/16S	20	16	30x2	24x1.5	45	36.5	60	27	36	30	
	HF-KOR-25S/16S	25	16	36x2	24x1.5	47.5	39	64.5	32	46	30	
	HF-KOR-30S/16S	30	16	42x2	24x1.5	53	44.5	69	41	50	30	
	HF-KOR-38S/16S	38	16	52x2	24x1.5	56.5	48	71	50	60	30	
	HF-KOR-25S/20S	25	20	36x2	30x2	49.5	39	67.5	32	46	36	
	HF-KOR-30S/20S	30	20	42x2	30x2	55	44.5	72	41	50	36	
	HF-KOR-38S/20S	38	20	52x2	30x2	58.5	48	74	50	60	36	
	HF-KOR-30S/25S	30	25	42x2	36x2	57	45	75	41	50	46	
HF-KOR-38S/25S	38	25	52x2	36x2	60.5	48.5	77	50	60	46		
HF-KOR-38S/30S	38	30	52x2	42x2	62.5	49	80	50	60	50		

ADJUSTABLE MALE 45° STUD ELBOW

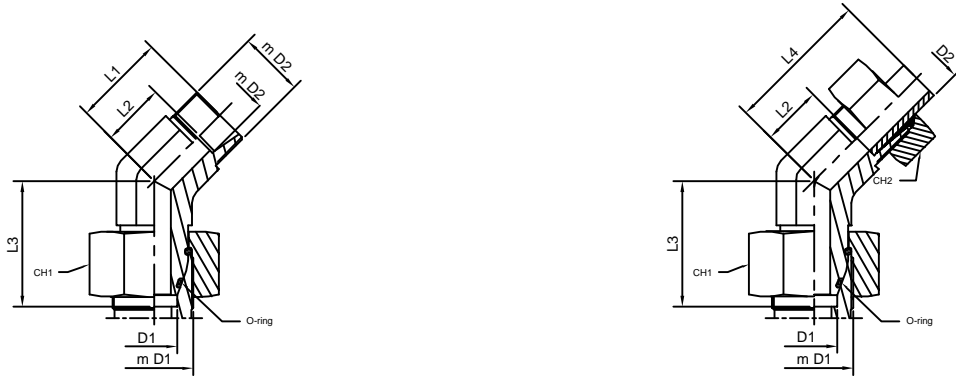

Series	W.P (Bar)	Part No.	Ø Tube		m D1	m D2	L1	L2	L3	L4	CH1	CH2
			D1	D2								
L	315	HF-SE45-6L	6	6	12X1.5	12X1.5	16	9	26	24	14	14
		HF-SE45-8L	8	8	14X1.5	14X1.5	17	10	27.5	25	17	17
		HF-SE45-10L	10	10	16X1.5	16X1.5	18	11	29	26	19	19
		HF-SE45-12L	12	12	18X1.5	18X1.5	19	12	29.5	27	22	22
	160	HF-SE45-15L	15	15	22X1.5	22X1.5	22	15	32.5	30	27	27
		HF-SE45-18L	18	18	26X1.5	26X1.5	24	16.5	35.5	33	32	32
		HF-SE45-22L	22	22	30X2	30X2	26	18	38.5	35	36	36
		HF-SE45-28L	28	28	36X2	36X2	30.5	23	41.5	39.5	41	41
S	630	HF-SE45-35L	35	35	45X2	45X2	34	23.5	51.5	45	50	50
		HF-SE45-42L	42	42	52X2	52X2	37	26	53	49	60	60
		HF-SE45-6S	6	6	14X1.5	14X1.5	18	11	27	26	17	17
		HF-SE45-8S	8	8	16X1.5	16X1.5	19	12	27.5	27	19	19
	400	HF-SE45-10S	10	10	18X1.5	18X1.5	20	12.5	30.5	29	22	22
		HF-SE45-12S	12	12	20X1.5	20X1.5	23	15.5	31.5	32	24	24
		HF-SE45-14S	14	14	22X1.5	22X1.5	24	16	35	34	27	27
		HF-SE45-16S	16	16	24X1.5	24X1.5	24	15.5	36.5	34	30	30
315	HF-SE45-20S	20	20	30X2	30X2	26.5	16	44.5	37.5	36	36	
	HF-SE45-25S	25	25	36X2	36X2	32	20	50	44	46	46	
315	HF-SE45-30S	30	30	42X2	42X2	37.5	24	55.5	50.5	50	50	
	HF-SE45-38S	38	38	52X2	52X2	40	24	58	55	60	60	
S/L	315	HF-SE45-6S/6L	6S	6L	14X1.5	12X1.5	16	9	27	24	17	14
		HF-SE45-8S/8L	8S	8L	16X1.5	14X1.5	17	10	27.5	25	19	17
		HF-SE45-10S/10L	10S	10L	18X1.5	16X1.5	18	11	30	26	22	19
		HF-SE45-12S/12L	12S	12L	20X1.5	18X1.5	19	12	31	27	24	22
L/S	315	HF-SE45-6L/6S	6L	6S	12X1.5	14X1.5	18	11	26	26	14	17
		HF-SE45-8L/8S	8L	8S	14X1.5	16X1.5	19	12	27.5	27	19	19
		HF-SE45-10L/10S	10L	10S	16X1.5	18X1.5	20	12.5	29.5	29	19	22
		HF-SE45-12L/12S	12L	12S	18X1.5	20X1.5	23	15.5	30	32	22	24

GAUGE COUPLING WITH SWIVEL NUT Thread BSP Parallel

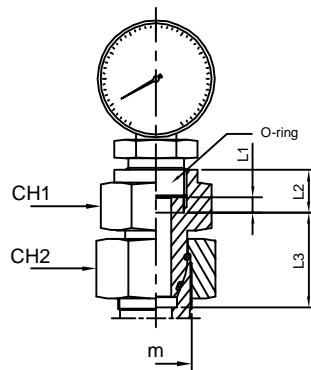

Series	W.P (Bar)	Part No.	ØTube	G	m	L1	L2	L3	CH1	CH2
L	315	HF-GA-6L-M12X1.5	6	1/4	12X1.5	4.5	14.5	21.5	19	14
		HF-GA-8L-M14X1.5	8	1/4	14X1.5	4.5	14.5	21.5	19	17
		HF-GA-10L-M16X1.5	10	1/4	16X1.5	4.5	14.5	22	19	19
		HF-GA-12L-M18X1.5	12	1/4	18X1.5	4.5	14.5	22	19	22
S	630	HF-GA-6S-M14X1.5	6	1/2	14X1.5	5	20	23	30	17
		HF-GA-8S-M16X1.5	8	1/2	16X1.5	5	20	23.5	30	19
		HF-GA-10S-M18X1.5	10	1/2	18X1.5	5	20	24.5	30	22
		HF-GA-12S-M20X1.5	12	1/2	20X1.5	5	20	24.5	30	24

DISTANCE PIECE ADAPTER WITH SWIVEL NUT



Series	W.P (Bar)	Part No.	Ø Tube D1 D2	m D1 m D2	L1	L2	L3	CH1	CH2
L	315	HF-DA-6L-M12X1.5	6	12X1.5	43	36	51	12	14
		HF-DA-8L-M14X1.5	8	14X1.5	43	36	51	14	17
		HF-DA-10L-M16X1.5	10	16X1.5	43	36	51	17	19
		HF-DA-12L-M18X1.5	12	18X1.5	43.5	36.5	51.5	19	22
		HF-DA-15L-M22X1.5	15	22X1.5	43.5	36.5	51.5	24	27
	160	HF-DA-18L-M26X1.5	18	26X1.5	44	36.5	53	27	32
		HF-DA-22L-M30X2	22	30X2	47	39.5	56	32	36
		HF-DA-28L-M36X2	28	36X2	47	39.5	56	41	41
		HF-DA-35L-M45X2	35	45X2	60	49.5	71	46	50
		HF-DA-42L-M52X2	42	52X2	71	60	83	55	60
S	630	HF-DA-6S-M14X1.5	6	14X1.5	43.5	36.5	51.5	14	17
		HF-DA-8S-M16X1.5	8	16X1.5	43.5	36.5	51.5	17	19
		HF-DA-10S-M18X1.5	10	18X1.5	44	36.5	53	19	22
		HF-DA-12S-M20X1.5	12	20X1.5	44	36.5	53	22	24
		HF-DA-14S-M22X1.5	14	22X1.5	48	40	58	24	27
	400	HF-DA-16S-M24X1.5	16	24X1.5	48.5	40	58.5	27	30
		HF-DA-20S-M30X2	20	30X2	56	45.5	67	32	36
		HF-DA-25S-M36X2	25	36X2	62	50	74	41	46
		HF-DA-30S-M42X2	30	42X2	69	55.5	82	46	50
		HF-DA-38S-M52X2	38	52X2	75.5	59.5	90.5	55	60

EQUAL NON RETURN VALVE

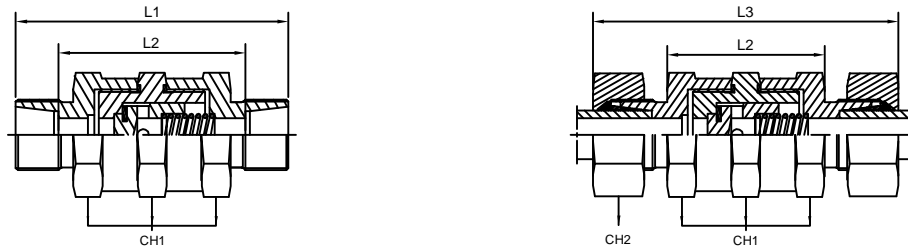

Series	W.P (Bar)	Part No.	Ø Tube	L1	L2	L3	CH1	CH2	Ø pass.
L	315	HF-NRV-6L	6	68	54	83	19	14	4
		HF-NRV-8L	8	68	54	83	19	17	4
		HF-NRV-10L	10	70	56	85	19	19	4
		HF-NRV-12L	12	76	62	91	32	22	8
		HF-NRV-15L	15	81	67	97	41	27	11
	160	HF-NRV-18L	18	81	66	98	41	32	11
		HF-NRV-22L	22	94	79	111	50	36	18
		HF-NRV-28L	28	94	79	112	50	41	18
		HF-NRV-35L	35	116	95	138	70	50	29
		HF-NRV-42L	42	116	94	139	70	60	29
S	630	HF-NRV-6S	6	72	58	87	19	17	4
		HF-NRV-8S	8	72	58	87	19	19	4
		HF-NRV-10S	10	78	63	95	32	22	7
		HF-NRV-12S	12	78	63	95	32	24	8
		HF-NRV-14S	14	85	69	104	41	27	10
	400	HF-NRV-16S	16	85	68	104	41	30	11
		HF-NRV-20S	20	98	77	120	50	36	16
		HF-NRV-25S	25	102	78	126	50	46	18
		HF-NRV-30S	30	124	97	150	70	50	25
		HF-NRV-38S	38	128	96	157	70	60	29

MALE STUD NON RETURN VALVE WITH ELASTOMER SEAL

Thread BSP Parallel - Thread Metric Parallel

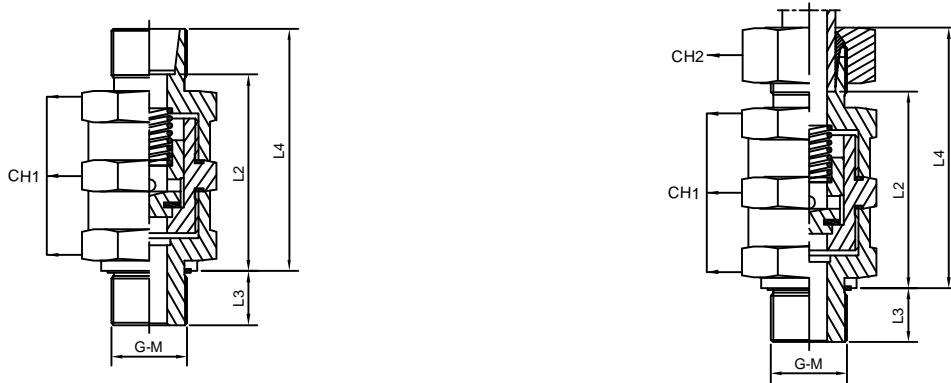

Series	W.P (Bar)	Part No.	Ø Tube	G	L1	L2	L3	L4	CH1	CH2	Ø pass.
L	315	HF-NRV-6L-1/8ED	6	1/8	60	53	8	67.5	19	14	4
		HF-NRV-8L-1/4ED	8	1/4	60	53	12	67.5	19	17	4
		HF-NRV-10L-1/4ED	10	1/4	61	54	12	68.5	19	19	4
		HF-NRV-12L-3/8ED	12	3/8	67.5	60.5	12	75	32	22	8
		HF-NRV-15L-1/2ED	15	1/2	72	65	14	80	41	27	11
	HF-NRV-18L-1/2ED	18	1/2	72	64.5	14	80.5	41	32	11	
	HF-NRV-22L-3/4ED	22	3/4	83	75.5	16	91.5	50	36	18	
	HF-NRV-28L-1ED	28	1	83	75.5	18	92	50	41	18	
S	630	HF-NRV-35L-1 1/4ED	35	1 1/4	103	92.5	20	114	70	50	29
		HF-NRV-42L-1 1/2ED	42	1 1/2	103	92	22	114.5	70	60	29
		HF-NRV-6S-1/4ED	6	1/4	62	55	12	69.5	19	17	4
		HF-NRV-8S-1/4ED	8	1/4	62	55	12	69.5	19	19	4
	400	HF-NRV-10S-3/8ED	10	3/8	68.5	61	12	77	32	22	7
		HF-NRV-12S-3/8ED	12	3/8	68.5	61	12	77	32	24	8
		HF-NRV-14S-1/2ED	14	1/2	74	66	14	83.5	41	27	10
		HF-NRV-16S-1/2ED	16	1/2	74	65.5	14	83.5	41	30	11
315	HF-NRV-20S-3/4ED	20	3/4	85	74.5	16	96	50	36	16	
	HF-NRV-25S-1ED	25	1	87	75	18	99	50	46	18	
	HF-NRV-30S-1 1/4ED	30	1 1/4	107	93.5	20	120	70	50	25	
	HF-NRV-38S-1 1/2ED	38	1 1/2	109	93	22	123.5	70	60	29	

Series	W.P (Bar)	Part No.	Ø Tube	M	L1	L2	L3	L4	CH1	CH2	Ø pass.
L	315	HF-NRV-6L-M10X1 ED	6	10X1	60	53	8	67.5	19	14	4
		HF-NRV-8L-M12X1.5 ED	8	12X1.5	60	53	12	67.5	19	17	4
		HF-NRV-10L-M14X1.5 ED	10	14X1.5	61	54	12	68.5	19	19	4
		HF-NRV-12L-M16X1.5 ED	12	16X1.5	67.5	60.5	12	75	32	22	8
		HF-NRV-15L-M18X1.5 ED	15	18X1.5	72	65	14	80	41	27	11
	HF-NRV-18L-M22X1.5 ED	18	22X1.5	72	64.5	14	80.5	41	32	11	
	HF-NRV-22L-M27X2 ED	22	27X2	83	75.5	16	91.5	50	36	18	
	HF-NRV-28L-M33X2 ED	28	33X2	83	75.5	18	92	50	41	18	
S	630	HF-NRV-35L-M42X2 ED	35	42X2	103	92.5	20	114	70	50	29
		HF-NRV-42L-M48X2 ED	42	48X2	103	92	22	114.5	70	60	29
		HF-NRV-6S-M12X1.5 ED	6	12X1.5	62	55	12	69.5	19	17	4
		HF-NRV-8S-M14X1.5 ED	8	14X1.5	62	55	12	69.5	19	19	4
	400	HF-NRV-10S-M16X1.5 ED	10	16X1.5	68.5	61	12	77	32	22	7
		HF-NRV-12S-M18X1.5 ED	12	18X1.5	68.5	61	12	77	32	24	8
		HF-NRV-14S-M20X1.5 ED	14	20X1.5	74	66	14	83.5	41	27	10
		HF-NRV-16S-M22X1.5 ED	16	22X1.5	74	65.5	14	83.5	41	30	11
315	HF-NRV-20S-M27X2 ED	20	27X2	85	74.5	16	96	50	36	16	
	HF-NRV-25S-M33X2 ED	25	33X2	87	75	18	99	50	46	18	
	HF-NRV-30S-M42X2 ED	30	42X2	107	93.5	20	120	70	50	25	
	HF-NRV-38S-M48X2 ED	38	48X2	109	93	22	123.5	70	60	29	

MALE STUD NON RETURN VALVE WITH ELASTOMER SEAL

Thread BSP Parallel - Thread Metric Parallel

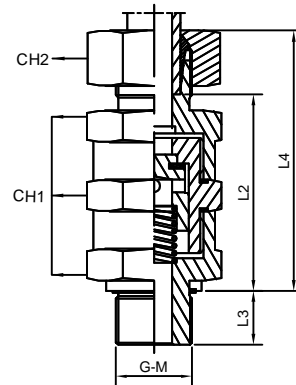
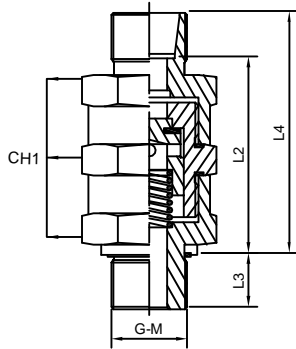

Series	W.P (Bar)	Part No.	Ø Tube	G	L1	L2	L3	L4	CH1	CH2	Ø pass.
L	315	HF-NRVE-6L-1/8 ED	6	1/8	60	53	8	67.5	19	14	4
		HF-NRVE-8L-1/4 ED	8	1/4	60	53	12	67.5	19	17	4
		HF-NRVE-10L-1/4 ED	10	1/4	61	54	12	68.5	19	19	4
		HF-NRVE-12L-3/8 ED	12	3/8	67.5	60.5	12	75	32	22	8
		HF-NRVE-15L-1/2 ED	15	1/2	72	65	14	80	41	27	11
	HF-NRVE-18L-1/2 ED	18	1/2	72	64.5	14	80.5	41	32	11	
	160	HF-NRVE-22L-3/4 ED	22	3/4	83	75.5	16	91.5	50	36	18
		HF-NRVE-28L-1 ED	28	1	83	75.5	18	92	50	41	18
HF-NRVE-35L-1 1/4 ED		35	1 1/4	103	92.5	20	114	70	50	29	
S	630	HF-NRVE-42L-1 1/2 ED	42	1 1/2	103	92	22	114.5	70	60	29
		HF-NRVE-6S-1/4 ED	6	1/4	62	55	12	69.5	19	17	4
		HF-NRVE-8S-1/4 ED	8	1/4	62	55	12	69.5	19	19	4
		HF-NRVE-10S-3/8 ED	10	3/8	68.5	61	12	77	32	22	7
		HF-NRVE-12S-3/8 ED	12	3/8	68.5	61	12	77	32	24	8
	400	HF-NRVE-14S-1/2 ED	14	1/2	74	66	14	83.5	41	27	10
		HF-NRVE-16S-1/2 ED	16	1/2	74	65.5	14	83.5	41	30	11
		HF-NRVE-20S-3/4 ED	20	3/4	85	74.5	16	96	50	36	16
315	HF-NRVE-25S-1 ED	25	1	87	75	18	99	50	46	18	
	HF-NRVE-30S-1 1/4 ED	30	1 1/4	107	93.5	20	120	70	50	25	
		HF-NRVE-38S-1 1/2 ED	38	1 1/2	109	93	22	123.5	70	60	29

Series	W.P (Bar)	Part No.	Ø Tube	M	L1	L2	L3	L4	CH1	CH2	Ø pass.
L	315	HF-NRVE-6L-M10X1 ED	6	10X1	60	53	8	67.5	19	14	4
		HF-NRVE-8L-M12X1.5 ED	8	12X1.5	60	53	12	67.5	19	17	4
		HF-NRVE-10L-M14X1.5 ED	10	14X1.5	61	54	12	68.5	19	19	4
		HF-NRVE-12L-M16X1.5 ED	12	16X1.5	67.5	60.5	12	75	32	22	8
		HF-NRVE-15L-M18X1.5 ED	15	18X1.5	72	65	14	80	41	27	11
	160	HF-NRVE-18L-M22X1.5 ED	18	22X1.5	72	64.5	14	80.5	41	32	11
		HF-NRVE-22L-M27X2 ED	22	27X2	83	75.5	16	91.5	50	36	18
		HF-NRVE-28L-M33X2 ED	28	33X2	83	75.5	18	92	50	41	18
S	630	HF-NRVE-35L-M42X2 ED	35	42X2	103	92.5	20	114	70	50	29
		HF-NRVE-42L-M48X2 ED	42	48X2	103	92	22	114.5	70	60	29
		HF-NRVE-6S-M12X1.5 ED	6	12X1.5	62	55	12	69.5	19	17	4
		HF-NRVE-8S-M14X1.5 ED	8	14X1.5	62	55	12	69.5	19	19	4
		HF-NRVE-10S-M16X1.5 ED	10	16X1.5	68.5	61	12	77	32	22	7
	400	HF-NRVE-12S-M18X1.5 ED	12	18X1.5	68.5	61	12	77	32	24	8
		HF-NRVE-14S-M20X1.5 ED	14	20X1.5	74	66	14	83.5	41	27	10
		HF-NRVE-16S-M22X1.5 ED	16	22X1.5	74	65.5	14	83.5	41	30	11
315	HF-NRVE-20S-M27X2 ED	20	27X2	85	74.5	16	96	50	36	16	
	HF-NRVE-25S-M33X2 ED	25	33X2	87	75	18	99	50	46	18	
		HF-NRVE-30S-M42X2 ED	30	42X2	107	93.5	20	120	70	50	25
		HF-NRVE-38S-M48X2 ED	38	48X2	109	93	22	123.5	70	60	29

MALE STUD NON RETURN VALVE

Thread BSP Taper - Thread NPT

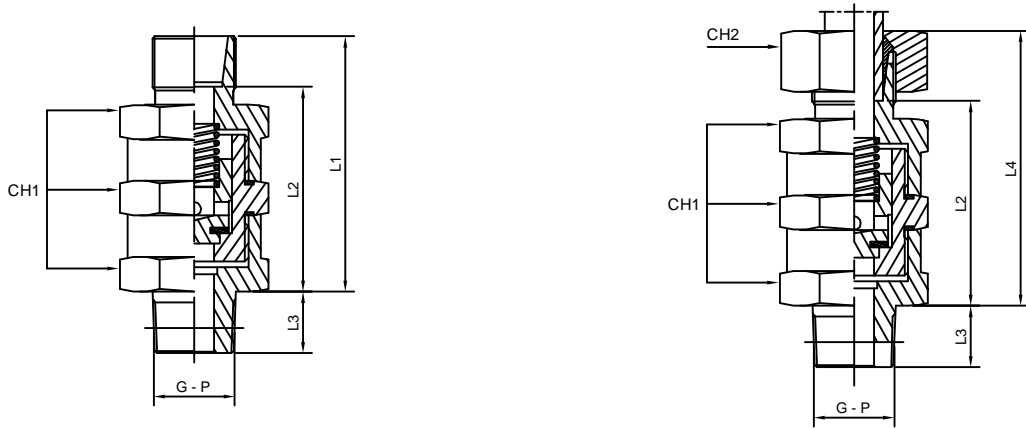

Series	W.P (Bar)	Part No.	Ø Tube	G	L1	L2	L3	L4	CH1	CH2	Ø pass.
L	315	HF-NRV-6L-1/8 T	6	1/8	58	51	10	65.5	19	14	4
		HF-NRV-8L-1/4 T	8	1/4	58	51	15	65.5	19	17	4
		HF-NRV-10L-1/4 T	10	1/4	59	52	15	66.5	19	19	4
		HF-NRV-12L-3/8 T	12	3/8	65	58	15	72.5	32	22	8
		HF-NRV-15L-1/2 T	15	1/2	69	62	19	77	41	27	11
	HF-NRV-18L-1/2 T	18	1/2	69	61.5	19	77.5	41	32	11	
	160	HF-NRV-22L-3/4 T	22	3/4	80	72.5	19	88.5	50	36	16
		HF-NRV-28L-1 T	28	1	80	72.5	24	89	50	41	18
HF-NRV-35L-1 1/4 T		35	1 1/4	100	89.5	25	111	70	50	25	
S	630	HF-NRV-42L-1/8 T	42	1 1/2	100	89	25	111.5	70	60	29
		HF-NRV-6S-1/4 T	6	1/4	60	53	15	67.5	19	17	4
		HF-NRV-8S-1/4 T	8	1/4	60	53	15	67.5	19	19	4
		HF-NRV-10S-3/8 T	10	3/8	66	58.5	15	74.5	32	22	7
		HF-NRV-12S-3/8 T	12	3/8	66	58.5	15	74.5	32	24	8
	400	HF-NRV-14S-1/2 T	14	1/2	71	63	19	80.5	41	27	10
		HF-NRV-16S-1/2 T	16	1/2	71	62.5	19	80.5	41	30	11
		HF-NRV-20S-3/4 T	20	3/4	82	71.5	19	93	50	36	16
		HF-NRV-35S-1 T	25	1	84	72	24	96	50	46	18
		HF-NRV-30S-1 1/4 T	30	1 1/4	104	90.5	25	117	70	50	25
315	HF-NRV-38S-1/2 T	38	1 1/2	106	90	25	120.5	70	60	29	

Series	W.P (Bar)	Part No.	Ø Tube	P	L1	L2	L3	L4	CH1	CH2	Ø pass.
L	315	HF-NRV-1/8 T	6	1/8	58	51	10	65.5	19	14	4
		HF-NRV-1/4 T	8	1/4	58	51	15	65.5	19	17	4
		HF-NRV-1/4 T	10	1/4	59	52	15	66.5	19	19	4
		HF-NRV-3/8 T	12	3/8	65	58	15	72.5	32	22	8
		HF-NRV-1/2 T	15	1/2	69	62	19	77	41	27	11
	HF-NRV-1/2 T	18	1/2	69	61.5	19	77.5	41	32	11	
	160	HF-NRV-3/4 T	22	3/4	80	72.5	19	88.5	50	36	16
		HF-NRV-1 T	28	1	80	72.5	24	89	50	41	18
HF-NRV-1 1/4 T		35	1 1/4	100	89.5	25	111	70	50	25	
S	630	HF-NRV-1/8 T	42	1 1/2	100	89	25	111.5	70	60	29
		HF-NRV-1/4 T	6	1/4	60	53	15	67.5	19	17	4
		HF-NRV-1/4 T	8	1/4	60	53	15	67.5	19	19	4
		HF-NRV-3/8 T	10	3/8	66	58.5	15	74.5	32	22	7
		HF-NRV-3/8 T	12	3/8	66	58.5	15	74.5	32	24	8
	400	HF-NRV-1/2 T	14	1/2	71	63	19	80.5	41	27	10
		HF-NRV-1/2 T	16	1/2	71	62.5	19	80.5	41	30	11
		HF-NRV-3/4 T	20	3/4	82	71.5	19	93	50	36	16
		HF-NRV-1 T	25	1	84	72	24	96	50	46	18
		HF-NRV-1 1/4 T	30	1 1/4	104	90.5	25	117	70	50	25
315	HF-NRV-1/2 T	38	1 1/2	106	90	25	120.5	70	60	29	

MALE STUD NON RETURN VALVE

Thread BSP Taper - Thread NPT

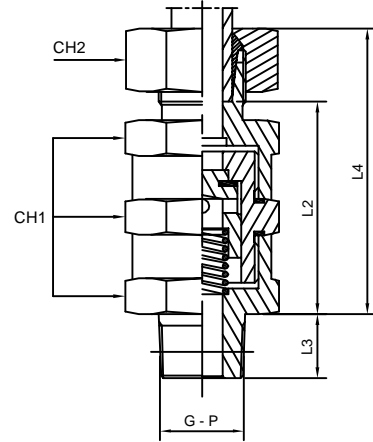
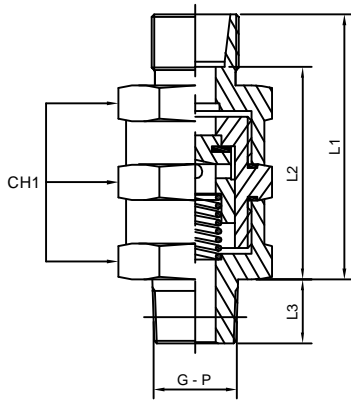

Series	W.P (Bar)	Part No.	Ø Tube	G	L1	L2	L3	L4	CH1	CH2	Ø pass.
L	315	HF-NRV-6L-1/8 T	6	1/8	58	51	10	65.5	19	14	4
		HF-NRV-8L-1/4 T	8	1/4	58	51	15	65.5	19	17	4
		HF-NRV-10L-1/4 T	10	1/4	59	52	15	66.5	19	19	4
		HF-NRV-12L-3/8 T	12	3/8	65	58	15	72.5	32	22	8
		HF-NRV-15L-1/2 T	15	1/2	69	62	19	77	41	27	11
	HF-NRV-18L-1/2 T	18	1/2	69	61.5	19	77.5	41	32	11	
	HF-NRV-22L-3/4 T	22	3/4	80	72.5	19	88.5	50	36	16	
	HF-NRV-28L-1 T	28	1	80	72.5	24	89	50	41	18	
S	630	HF-NRV-35L-1 1/4 T	35	1 1/4	100	89.5	25	111	70	50	25
		HF-NRV-42L-1/8 T	42	1 1/2	100	89	25	111.5	70	60	29
		HF-NRV-6S-1/4 T	6	1/4	60	53	15	67.5	19	17	4
		HF-NRV-8S-1/4 T	8	1/4	60	53	15	67.5	19	19	4
	400	HF-NRV-10S-3/8 T	10	3/8	66	58.5	15	74.5	32	22	7
		HF-NRV-12S-3/8 T	12	3/8	66	58.5	15	74.5	32	24	8
		HF-NRV-14S-1/2 T	14	1/2	71	63	19	80.5	41	27	10
		HF-NRV-16S-1/2 T	16	1/2	71	62.5	19	80.5	41	30	11
HF-NRV-20S-3/4 T		20	3/4	82	71.5	19	93	50	36	16	
HF-NRV-35S-1 T		25	1	84	72	24	96	50	46	18	
HF-NRV-30S-1 1/4 T		30	1 1/4	104	90.5	25	117	70	50	25	
HF-NRV-38S-1 1/2 T		38	1 1/2	106	90	25	120.5	70	60	29	

Series	W.P (Bar)	Part No.	Ø Tube	P	L1	L2	L3	L4	CH1	CH2	Ø pass.
L	315	HF-NRV-1/8 T	6	1/8	58	51	10	65.5	19	14	4
		HF-NRV-1/4 T	8	1/4	58	51	15	65.5	19	17	4
		HF-NRV-1/4 T	10	1/4	59	52	15	66.5	19	19	4
		HF-NRV-3/8 T	12	3/8	65	58	15	72.5	32	22	8
		HF-NRV-1/2 T	15	1/2	69	62	19	77	41	27	11
	HF-NRV-1/2 T	18	1/2	69	61.5	19	77.5	41	32	11	
	160	HF-NRV-3/4 T	22	3/4	80	72.5	19	88.5	50	36	16
		HF-NRV-1 T	28	1	80	72.5	24	89	50	41	18
HF-NRV-1 1/4 T		35	1 1/4	100	89.5	25	111	70	50	25	
S	630	HF-NRV-1/8 T	42	1 1/2	100	89	25	111.5	70	60	29
		HF-NRV-1/4 T	6	1/4	60	53	15	67.5	19	17	4
		HF-NRV-1/4 T	8	1/4	60	53	15	67.5	19	19	4
		HF-NRV-3/8 T	10	3/8	66	58.5	15	74.5	32	22	7
	400	HF-NRV-3/8 T	12	3/8	66	58.5	15	74.5	32	24	8
		HF-NRV-1/2 T	14	1/2	71	63	19	80.5	41	27	10
		HF-NRV-1/2 T	16	1/2	71	62.5	19	80.5	41	30	11
		HF-NRV-3/4 T	20	3/4	82	71.5	19	93	50	36	16
HF-NRV-1 T		25	1	84	72	24	96	50	46	18	
HF-NRV-1 1/4 T		30	1 1/4	104	90.5	25	117	70	50	25	
315		HF-NRV-1/2 T	38	1 1/2	106	90	25	120.5	70	60	29

2-WAY BALL VALVE

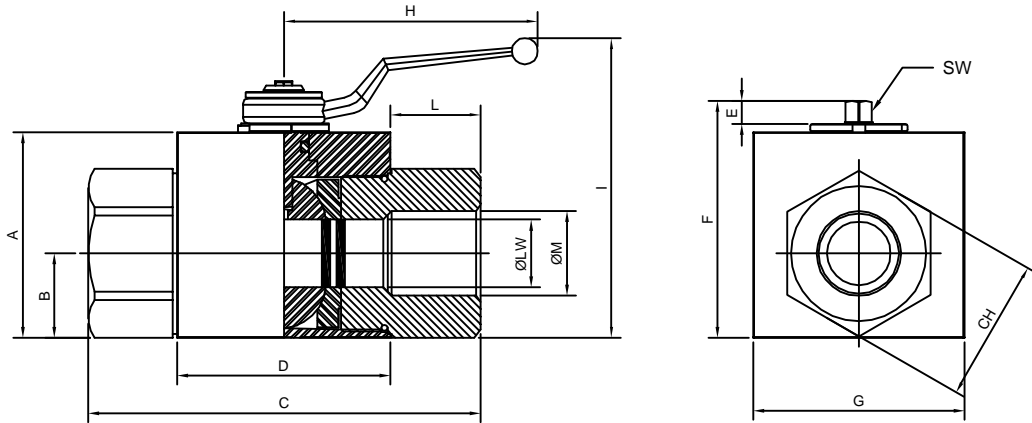

GE2 DIN/ISO 228 BSP

Part no.	ØM	ØLW	A	B	C	D	E	F	G	H	I	L	CH	SW
HF-BV-2-G1/8	G 1/8	4	35	14.5	71	42.4	11	49	30	110	91.5	11	24	9
HF-BV-2-G1/4	G 1/4	6	35	14.5	71	42.4	11	49	30	110	91.5	15.5	24	9
HF-BV-2-G3/8	G 3/8	10	40	17.4	73	44.4	11	54.25	35	110	96.5	15.5	30	9
HF-BV-2-G1/2	G 1/2	13	43	18	83	48.4	11	57	37	110	99.5	17	32	9
HF-BV-2-G3/4	G 3/4	20	57	23.4	95	62.5	14	73.5	49	180	106.5	21	41	14
HF-BV-2-G1	G 1	25	65	29.5	112	66.5	14	83.5	55	180	116.5	24	50	14
HF-BV-2-G1 1/4	G 1 1/4	25	65	29.5	120	66.5	14	83.5	55	180	116.5	24	55	14
HF-BV-2-G1 1/2	G 1 1/2	25	65	29.5	124	66.5	14	83.5	55	180	116.5	24	60	14

GE2 ANSI/ASME B1.20.1 NPT

Part no.	ØM	ØLW	A	B	C	D	E	F	G	H	I	L	CH	SW
HF-BV-2-N1/8	N 1/8	4	35	14.5	71	42.4	11	49	30	110	91.5	11	24	9
HF-BV-2-N1/4	N 1/4	6	35	14.5	71	42.4	11	49	30	110	91.5	17	24	9
HF-BV-2-N3/8	N 3/8	10	40	17.4	73	44.4	11	54.25	35	110	96.5	17	30	9
HF-BV-2-N1/2	N 1/2	13	43	18	83	48.4	11	57	37	110	99.5	21	32	9
HF-BV-2-N3/4	N 3/4	20	57	23.4	95	62.5	14	73.5	49	180	106.5	21	41	14
HF-BV-2-N1	N 1	25	65	29.5	112	66.5	14	83.5	55	180	116.5	24	50	14
HF-BV-2-N1 1/4	N 1 1/4	25	65	29.5	120	66.5	14	83.5	55	180	116.5	24	55	14
HF-BV-2-N1 1/2	N 1 1/2	25	65	29.5	124	66.5	14	83.5	55	180	116.5	24	60	14

GE2 SAE J1926-1

Part no.	ØM	ØLW	A	B	C	D	E	F	G	H	I	L	CH	SW
HF-BV-2-7/16 UNF	7/16 UNF	6	35	14.5	71	42.4	11	49	30	110	91.5	15.5	24	9
HF-BV-2-9/16 UNF	9/16 UNF	10	40	17.4	73	44.4	11	54.25	35	110	96.5	16	30	9
HF-BV-2-3/4 UNF	3/4 UNF	13	43	18	83	48.4	11	57	37	110	99.5	17.5	32	9
HF-BV-2-1 1/16 UNF	1 1/16 UNF	20	57	23.4	95	62.5	14	73.5	49	180	106.5	23	41	14
HF-BV-2-1 5/16 UNF	1 5/16 UNF	25	65	29.5	112	66.5	14	83.5	55	180	116.5	23	50	14
HF-BV-2-1 5/8 UNF	1 5/8 UNF	25	65	29.5	120	66.5	14	83.5	55	180	116.5	23	55	14
HF-BV-2-1 7/8 UNF	1 7/8 UNF	25	65	29.5	124	66.5	14	83.5	55	180	116.5	23	60	14

2-WAY BALL VALVE

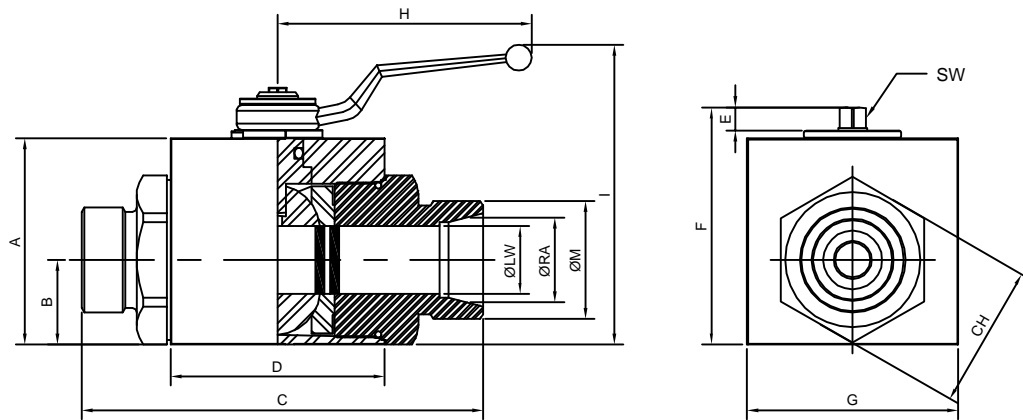

GE2 DIN 2353 HEAVY SERIES

Part no.	ØM	ØLW	ØRA	A	B	C	D	E	F	G	H	I	L	CH	SW
HF-BV-2-8S	M16x1.5	4	8	35	14.5	76	42.4	11	49	30	110	91.5	7	24	9
HF-BV-2-10S	M18x1.5	6	10	35	14.5	76	42.4	11	49	30	110	91.5	7.5	24	9
HF-BV-2-12S	M20x1.5	8	12	35	14.5	76	42.4	11	49	30	110	91.5	7.5	24	9
HF-BV-2-12S	M20x1.5	10	12	40	17.4	76	44.4	11	54.25	35	110	96.5	7.5	30	9
HF-BV-2-14S	M22x1.5	10	14	40	17.4	82.5	44.4	11	54.25	35	110	96.5	8	30	9
HF-BV-2-16S	M24x1.5	13	16	43	18	89	48.4	11	57	37	110	99.5	8.5	32	9
HF-BV-2-20S	M30x2	13	20	43	18	93	48.4	11	57	37	110	99.5	10.5	32	9
HF-BV-2-25S	M36x2	20	25	57	23.4	111	62.5	14	73.5	49	180	106.5	12	41	14
HF-BV-2-30S	M42x2	25	30	65	29.5	121	66.5	14	83.5	55	180	116.5	13	50	14
HF-BV-2-38S	M52x2	25	38	65	29.5	131	66.5	14	83.5	55	180	116.5	16	55	14

GE2 DIN 2353 LIGHT SERIES

Part no.	ØM	ØLW	ØRA	A	B	C	D	E	F	G	H	I	L	CH	SW
HF-BV-2-6L	M12x1.5	6	6	35	14.5	76	42.4	11	49	30	110	91.5	7	24	9
HF-BV-2-8L	M14x1.5	6	8	35	14.5	76	42.4	11	49	30	110	91.5	7	24	9
HF-BV-2-10L	M16x1.5	6	10	35	14.5	76	42.4	11	49	30	110	91.5	7	24	9
HF-BV-2-10L	M16x1.5	10	10	40	17.4	76.5	44.4	11	54.25	35	110	96.5	7	30	9
HF-BV-2-12L	M18x1.5	10	12	40	17.4	79.5	44.4	11	54.25	35	110	96.5	7	30	9
HF-BV-2-15L	M22x1.5	13	15	43	18	87	48.4	11	57	37	110	99.5	7	32	9
HF-BV-2-18L	M26x1.5	13	18	43	18	87	48.4	11	57	37	110	99.5	7.5	32	9
HF-BV-2-22L	M30x2	20	22	57	23.4	110	62.5	14	73.5	49	180	106.5	7.5	41	14
HF-BV-2-28L	M36x2	25	28	65	29.5	117	66.5	14	83.5	55	180	116.5	7.5	50	14
HF-BV-2-35L	M45x2	25	35	65	29.5	119	66.5	14	83.5	55	180	116.5	10.5	55	14
HF-BV-2-42L	M52x2	25	42	65	29.5	119	66.5	14	83.5	55	180	116.5	11	55	14

3-WAY BALL VALVE

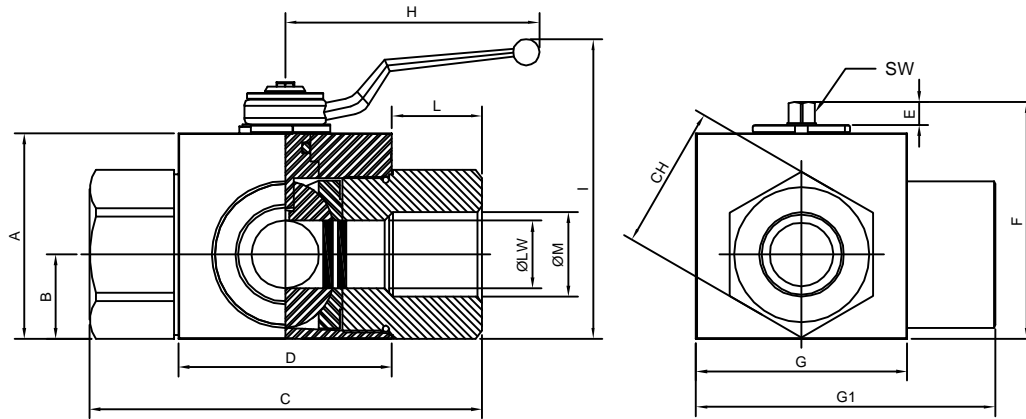

GE3 DIN/ISO 228 BSP

Part no.	ØM	ØLW	A	B	C	D	E	F	G	G1	H	I	L	CH	SW
HF-BV-3-G1/8	G 1/8	4	35	14.5	71	42.4	11	49	30	48.5	110	91.5	11	24	9
HF-BV-3-G1/4	G 1/4	6	35	14.5	71	42.4	11	49	30	48.5	110	91.5	15.5	24	9
HF-BV-3-G3/8	G 3/8	10	40	17.4	73	44.4	11	54.25	35	54.5	110	96.5	15.5	30	9
HF-BV-3-G1/2	G 1/2	13	43	18	83	48.4	11	57	37	58.5	110	99.5	17	32	9
HF-BV-3-G3/4	G 3/4	20	57	23.4	95	62.5	14	73.5	49	75	180	106.5	21	41	14
HF-BV-3-G1	G 1	25	65	29.5	112	66.5	14	83.5	55	89	180	116.5	24	50	14
HF-BV-3-G1 1/4	G 1 1/4	25	65	29.5	120	66.5	14	83.5	55	89	180	116.5	24	55	14
HF-BV-3-G1 1/2	G 1 1/2	25	65	29.5	124	66.5	14	83.5	55	89	180	116.5	24	60	14

GE3 ANSI/ASME B1.20.1 NPT

Part no.	ØM	ØLW	A	B	C	D	E	F	G	G1	H	I	L	CH	SW
HF-BV-3-N1/8	N 1/8	4	35	14.5	71	42.4	11	49	30	48.5	110	91.5	11	24	9
HF-BV-3-N1/4	N 1/4	6	35	14.5	71	42.4	11	49	30	48.5	110	91.5	17	24	9
HF-BV-3-N3/8	N 3/8	10	40	17.4	73	44.4	11	54.25	35	54.5	110	96.5	17	30	9
HF-BV-3-N1/2	N 1/2	13	43	18	83	48.4	11	57	37	58.5	110	99.5	21	32	9
HF-BV-3-N3/4	N 3/4	20	57	23.4	95	62.5	14	73.5	49	75	180	106.5	21	41	14
HF-BV-3-N1	N 1	25	65	29.5	112	66.5	14	83.5	55	89	180	116.5	24	50	14
HF-BV-3-N1 1/4	N 1 1/4	25	65	29.5	120	66.5	14	83.5	55	89	180	116.5	24	55	14
HF-BV-3-N1 1/2	N 1 1/2	25	65	29.5	124	66.5	14	83.5	55	89	180	116.5	24	60	14

GE3 SAE J1926-1

Part no.	ØM	ØLW	A	B	C	D	E	F	G	G1	H	I	L	CH	SW
HF-BV-3-7/16UNF	7/16UNF	6	35	14.5	71	42.4	11	49	30	48.5	110	91.5	15.5	24	9
HF-BV-3-9/16UNF	9/16UNF	10	40	17.4	73	44.4	11	54.25	35	54.5	110	96.5	16	30	9
HF-BV-3-3/4UNF	3/4UNF	13	43	18	83	48.4	11	57	37	58.5	110	99.5	17.5	32	9
HF-BV-3-1 1/16UNF	1 1/16UNF	20	57	23.4	95	62.5	14	73.5	49	75	180	106.5	23	41	14
HF-BV-3-1 5/16UNF	1 5/16UNF	25	65	29.5	112	66.5	14	83.5	55	89	180	116.5	23	50	14
HF-BV-3-1 5/8UNF	1 5/8UNF	25	65	29.5	120	66.5	14	83.5	55	89	180	116.5	23	55	14
HF-BV-3-1 7/8UNF	1 7/8UNF	25	65	29.5	124	66.5	14	83.5	55	89	180	116.5	23	60	14

3-WAY BALL VALVE

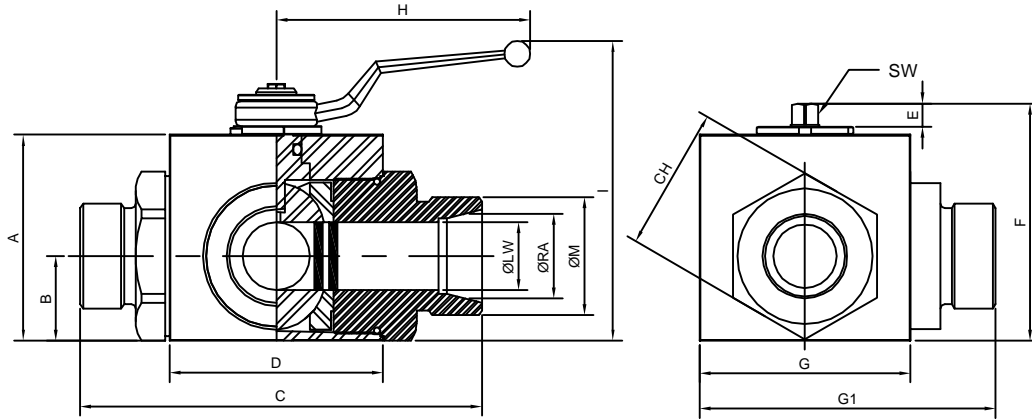

GE3 DIN 2353 HEAVY SERIES

Part no.	ØM	ØLW	ØRA	A	B	C	D	E	F	G	G1	H	I	L	CH	SW
HF-BV-3-8S	M16X1.5	4	8	35	14.5	76	42.4	11	49	30	48.5	110	91.5	77	24	9
HF-BV-3-10S	M18X1.5	6	10	35	14.5	76	42.4	11	49	30	48.5	110	91.5	7.5	24	9
HF-BV-3-12S	M20X1.5	8	12	35	14.5	76	42.4	11	49	30	48.5	110	91.5	7.5	24	9
HF-BV-3-12S	M20X1.5	10	12	40	17.4	76	44.4	11	54.25	35	54.5	110	96.5	7.5	30	9
HF-BV-3-14S	M22X1.5	10	14	40	17.4	82.5	44.4	11	54.25	35	54.5	110	96.5	8	30	9
HF-BV-3-16S	M24X1.5	13	16	43	18	89	48.4	11	57	37	59	110	99.5	8.5	32	9
HF-BV-3-20S	M30X2	13	20	43	18	93	48.4	11	57	37	59	110	99.5	10.5	32	9
HF-BV-3-25S	M36X2	20	25	57	23.4	111	62.5	14	73.5	49	75	180	106.5	12	41	14
HF-BV-3-30S	M42X2	25	30	65	29.5	121	66.5	14	83.5	55	89	180	116.5	13	50	14
HF-BV-3-38S	M52X2	25	38	65	29.5	131	66.5	14	83.5	55	89	180	116.5	16	55	14

GE2 DIN 2353 LIGHT SERIES

Part no.	ØM	ØLW	A	B	C	D	E	F	G	G1	H	I	L	CH	SW
HF-BV-3-6L	M12X1.5	6	35	14.5	76	42.4	11	49	303	48.5	110	91.5	7	24	9
HF-BV-3-8L	M14X1.5	6	35	14.5	76	42.4	11	49	0	48.5	110	91.5	7	24	9
HF-BV-3-10L	M16X1.5	6	35	14.5	76	42.4	11	49	30	48.5	110	91.5	7	24	9
HF-BV-3-10L	M16X1.5	10	40	17.4	76.5	44.4	11	54.25	35	54.5	110	96.5	7	30	9
HF-BV-3-12L	M18X1.5	10	40	17.4	79.5	44.4	11	54.25	35	54.5	110	96.5	7	30	9
HF-BV-3-15L	M22X1.5	13	43	18	87	48.4	11	57	37	59	110	99.5	7	32	9
HF-BV-3-18L	M26X1.5	13	43	18	87	48.4	11	57	37	59	110	99.5	7.5	32	9
HF-BV-3-22L	M30X2	20	57	23.4	110	62.5	14	73.5	49	75	180	106.5	7.5	41	14
HF-BV-3-28L	M36X2	25	65	29.5	117	66.5	14	83.5	55	89	180	116.5	7.5	50	14
HF-BV-3-35L	M45X2	25	65	29.5	119	66.5	14	83.5	55	89	180	116.5	10.5	50	14
HF-BV-3-42L	M52X2	25	65	29.5	119	66.5	14	83.5	55	89	180	116.5	11	55	14

Check Valve

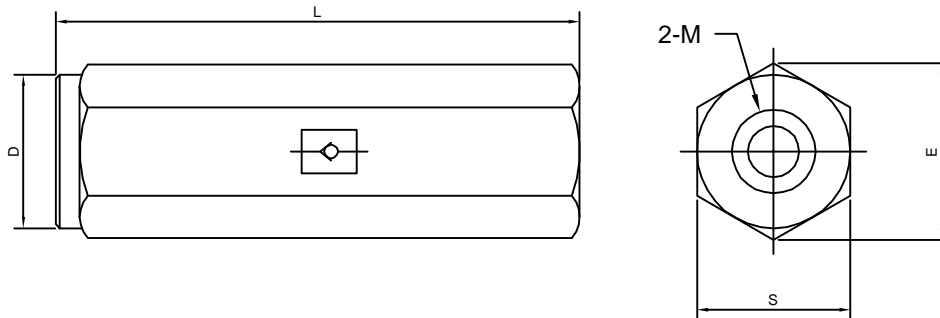

1. Series Code : NRV
 2. Nominal Diameter : 08, 10, 12, 16, 20, 25, 30, 40
 3. Thread Code : BSP
 4. Nominal Diameter : 1/4, 3/8, 1/2, 3/4, 1, 1 1/4, 1 1/2, 2
- PS. : Hydraulic oil as the medium is preferable

Technical Specifications

Valve body material : 45#
 Surface treatment : Silver zinc plated

Symbol

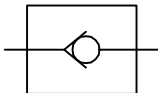

Nominal Diameter	Part No.	L/min	PN (bar)	Cracking pressure (Mpa)	L	E	S	D	M (BSP)
8	HF-NRV-1/4	30	500	0.05	62	21.5	19	19	1/4"
10	HF-NRV-3/8	45	500	0.05	68	27.5	24	24	3/8"
12	HF-NRV-1/2	70	500	0.05	77	34.5	30	30	1/2"
16	HF-NRV-3/4	110	400	0.05	88	41.5	36	36	3/4"
20	HF-NRV-1	160	350	0.05	105	47	41	41	1"
25	HF-NRV-1 1/4	210	350	0.05	130	63	55	55	1 1/4"
30	HF-NRV-1 1/2	320	350	0.05	138	75	65	65	1 1/2"
40	HF-NRV-2	460	250	0.05	160	92	80	80	2"

Throttle Check Valve

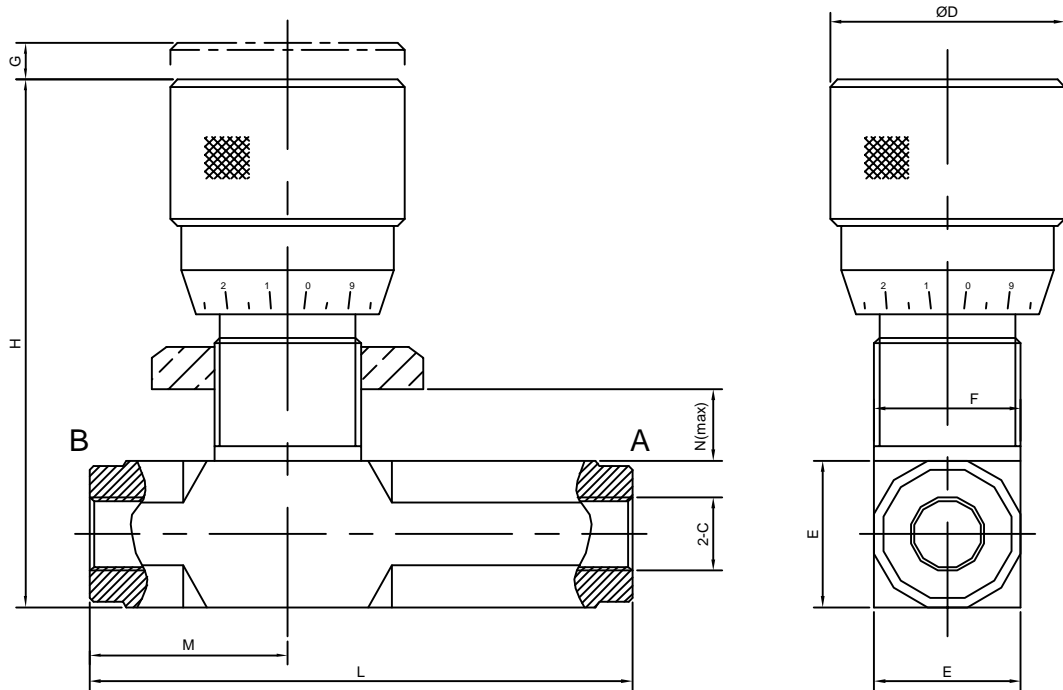

1. Series Code : TCV
2. Thread Code : BSP
3. Nominal Diameter : 1/4, 3/8, 1/2, 3/4, 1
4. Structure : L-with impact nut blank-without impact nut
5. Valve body material : 1-carbon steel
6. Stem material : 1-carbon steel
7. Valve core material : 1-400Cr
8. Spring material : 1-SWP-B
9. Surface Treatment : 1-Silver zinc Plated

Symbol

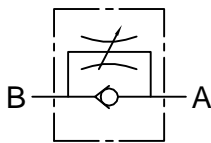

Part No.	C	L	H	D	E	F*	G	M	N	Mpa (Bar)	L/min
HF-TCV-1/4	1/4	73	72	32	20	M20x1	5	27	7	40	12
HF-TCV-3/8	3/8	82	80	32	25	M25x1.5	9	31	7	40	30
HF-TCV-1/2	1/2	98	92	45	30	M30x1.5	9	36.5	9	40	50
HF-TCV-3/4	3/4	112	100	45	40	M35x1.5	10	42	11	40	85
HF-TCV-1	1	142	122	45	45	M40x1.5	12	51	15	32	150

Throttle Valve

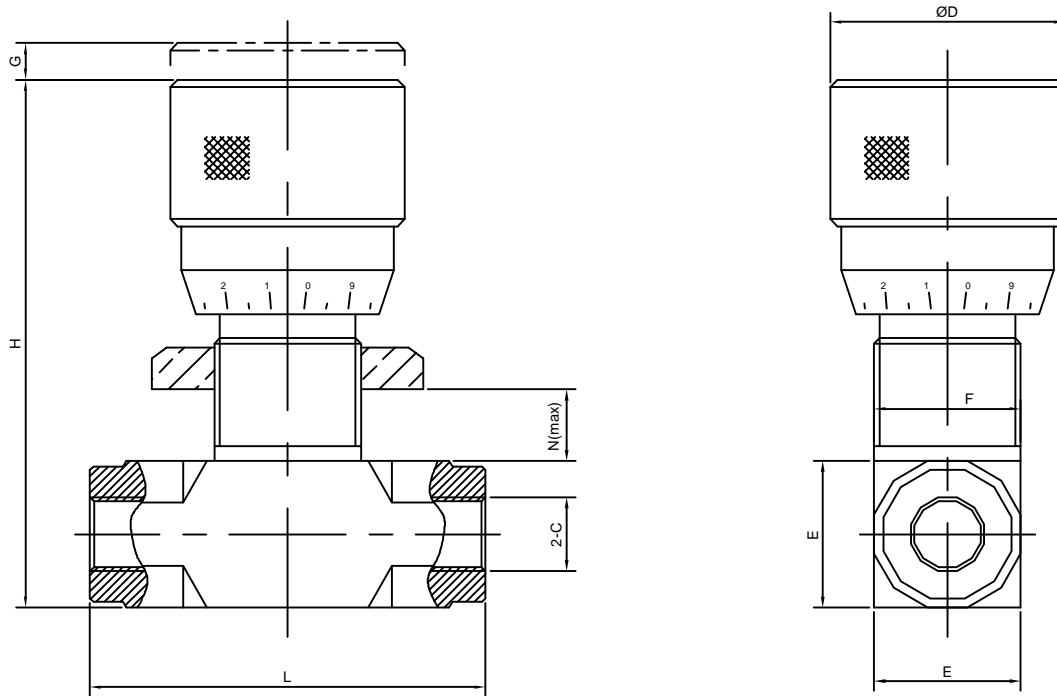

1. Series Code : TV
2. Thread Code : BSP
3. Nominal Diameter : 1/4, 3/8, 1/2, 3/4, 1
4. Structure : L-with impact nut blank-without impact nut
5. Valve body material : 1-carbon steel
6. Stem material : 1-carbon steel
7. Surface Treatment : 1-Silver zinc Plated

Symbol

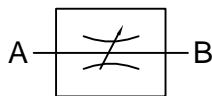

Part No.	C	L	H	D	E	F*	G	N	Mpa (Bar)	L/min
HF-TV-1/4	1/4	54	72	32	20	M20x1	5	7	40	12
HF-TV-3/8	3/8	62	80	32	25	M25x1.5	9	7	40	30
HF-TV-1/2	1/2	73	92	45	30	M30x1.5	9	9	40	50
HF-TV-3/4	3/4	84	100	45	40	M35x1.5	10	11	40	85
HF-TV-1	1	102	122	45	45	M40x1.5	12	15	32	150

Nominal Size				Max working pressure	Rated Flow	Max flow rate	Min burst pressure			Fluid spillage
							Male	Female	Coupled	
DPN	BG	ISO	mm	MPa	l/min	l/min	MPa	Mpa	Mpa	cc
06	1	6.3	6	30	12	24	180	120	140	0.008
13	2	10	8.6	25	23	46	160	100	160	0.010
20	3	12.5	10.7	25	45	90	150	110	190	0.012
25	4	19	14.8	25	100	200	140	110	140	0.020
30	5	25	17.6	25	189	280	130	100	140	0.030
35	6	31.5	26	25	260	520	100	120	110	0.040
39	7	40	30	25	379	700	120	120	110	0.050
50	8	50	40.6	25	757	1000	100	100	100	0.100

1 MPa = 145.04 psi • 1 l = 0.264 gal

Technical data

- Standard : ISO 16028
- Occlusion : flat face
- Locking : radial balls
- Material : steel
- Finishing : Zn-Fe (Cr III)
- Threads : BSP-NPT-SAE
- Working temperature : -25°C+100°C
- Optional seals : FKM, EPDM or more
- Working Pressure : 250-300 bar
- Connection under pressure : not allowed

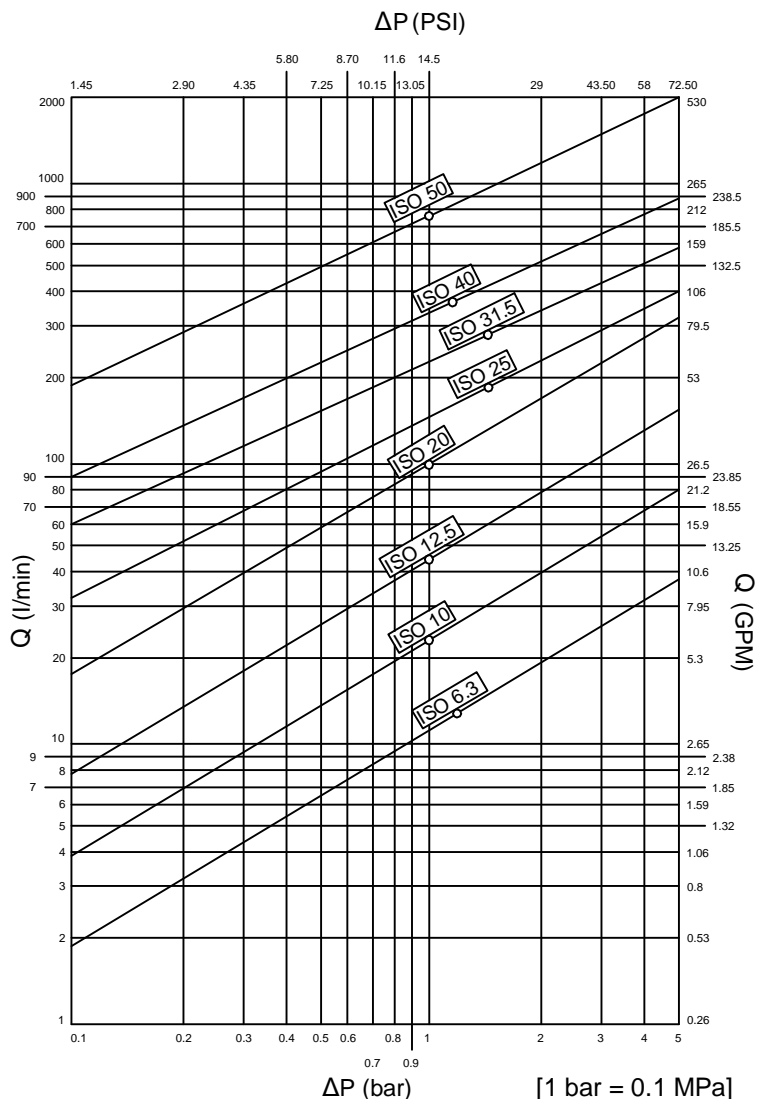

PLT1 DN06 - BG 1 - ISO 6.3

PLT1

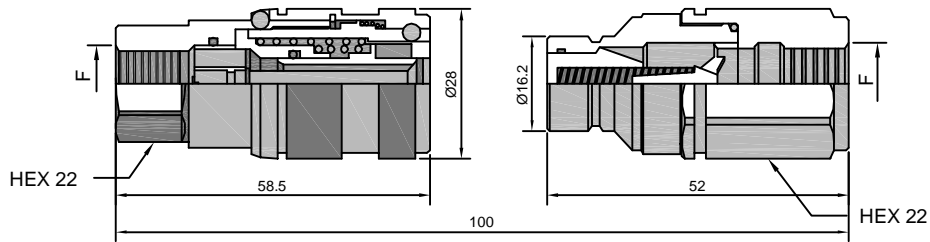

F	STANDARD	FEMALE			MALE		
		COD.F	Weight (g)	Packaging (pcs.)	COD. M	Weight (g)	Packaging (pcs.)
BSP 1/4"	DIN 3852-2-X	PLT1.0606.002	181	100	PLT1.0606.003	96	200
NPT 1/4"	ANSI B1.20.3	PLT1.0606.012	181	100	PLT1.0606.013	96	200

PLT1 DN13 - BG 2 - ISO 10

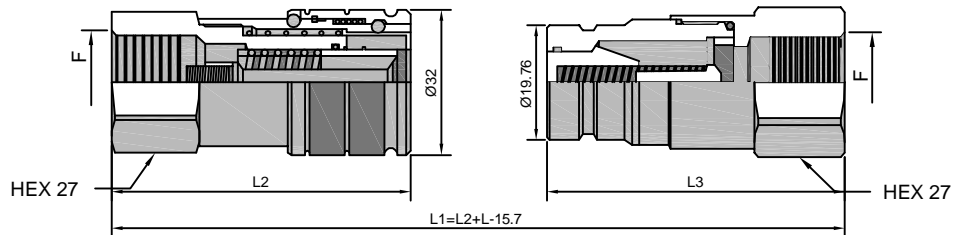

L2	L3	F	STANDARD	FEMALE			MALE		
				COD.F	Weight (g)	Packaging (pcs.)	COD. M	Weight (g)	Packaging (pcs.)
67.3	63.5	BSP 1/4"	DIN 3852-2-X	PLT1.1310.002	256	60	PLT1.1310.003	156	76
67.3	63.5	NPT 1/4"	ANSI B1.20.3	PLT1.1310.012	259	60	PLT1.1310.013	159	76
72.3	67.5	BSP 1/2"	DIN 3852-2-X	PLT1.1313.002	253	60	PLT1.1313.003	151	76
72.3	67.5	NPT 1/2"	ANSI B1.20.3	PLT1.1313.012	256	60	PLT1.1313.013	154	76

PLT1 DN20 - BG 3 - ISO 12.5

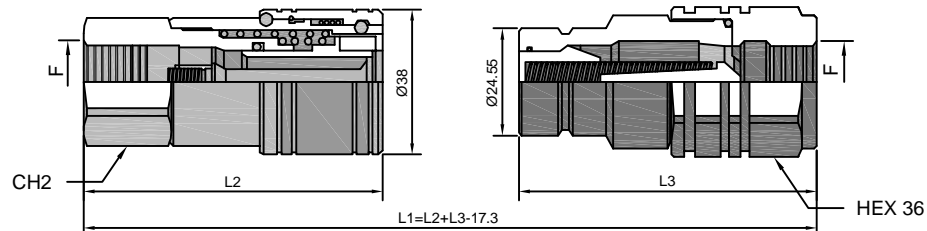

CH2	L2	L3	F	STANDARD	FEMALE			MALE		
					COD.F	Weight (g)	Packaging (pcs.)	COD. M	Weight (g)	Packaging (pcs.)
32	78.5	72.5	BSP 1/2"	DIN 3852-2-X	PLT1.2013.002	413	35	PLT1.2013.003	305	42
32	84	74	NPT 1/2"	ANSI B1.20.3	PLT1.2013.012	408	35	PLT1.2013.013	314	42
36	84	74.5	BSP 3/4"	DIN 3852-2-X	PLT1.2019.002	445	35	PLT1.2019.003	282	42
36	84	74	NPT 3/4"	ANSI B1.20.3	PLT1.2019.012	451	35	PLT1.2019.013	290	42

PLT1 DN25 - BG 4 - ISO 19

PLT1

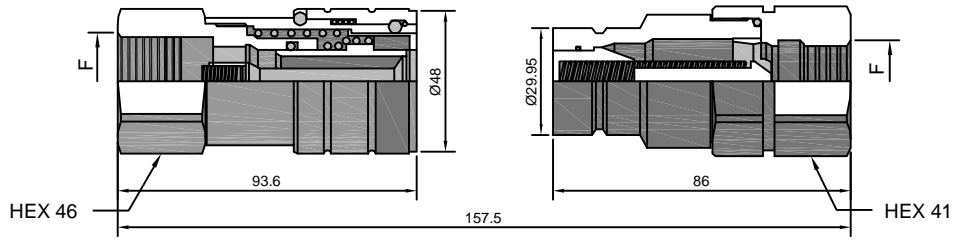

F	STANDARD	FEMALE			MALE		
		COD.F	Weight (g)	Packaging (pcs.)	COD. M	Weight (g)	Packaging (pcs.)
BSP 3/4"	DIN 3852-2-X	PLT1.2519.002	850	23	PLT1.2519.003	478	30
NPT 3/4"	ANSI B1.20.3	PLT1.2519.012	857	23	PLT1.2519.013	485	30
BSP 1"	DIN 3852-2-X	PLT1.2525.002	789	23	PLT1.2525.003	423	30
NPT 1"	ANSI B1.20.3	PLT1.2525.012	801	23	PLT1.2525.013	435	30

PLT1 DN30 - BG 5 - ISO 25

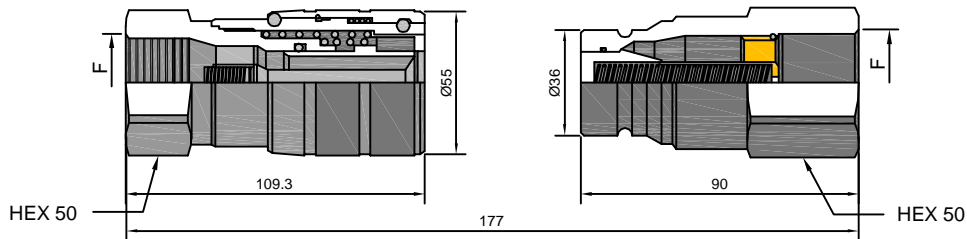

F	STANDARD	FEMALE			MALE		
		COD.F	Weight (g)	Packaging (pcs.)	COD. M	Weight (g)	Packaging (pcs.)
BSP 1 1/4"	DIN 3852-2-X	PLT1.3031.002	1139	7	PLT1.3031.003	648	20
NPT 1 1/4"	ANSI B1.20.3	PLT1.3031.012	1162	7	PLT1.3031.013	661	20

PLT1 DN35 - BG 6 - ISO 31.5

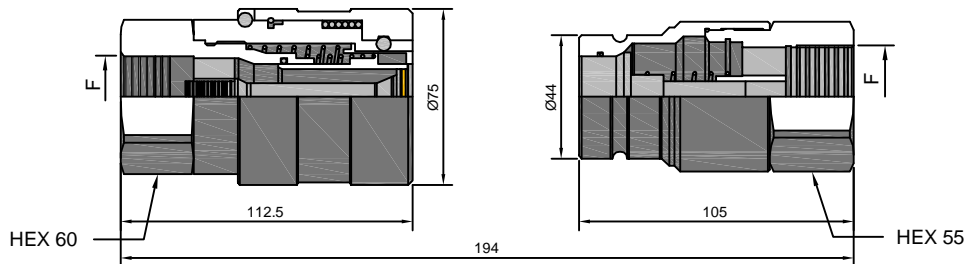

THREAD	F	STANDARD	FEMALE			MALE		
			COD.F	Weight (g)	Packaging (pcs.)	COD. M	Weight (g)	Packaging (pcs.)
IG 1	BSP 1 1/4"	DIN 3852-2-X	PLT1.3531.002	2376	8	PLT1.3531.003	1117	18
	NPT 1 1/4"	ANSI B1.20.3	PLT1.3531.012	2400	8	PLT1.3531.013	1130	18
IG2	1 5/8-12 UN 2B	SAE J 1926-1	PLT1.3541.032	2388	8	PLT1.3541.033	1120	18

THREADS

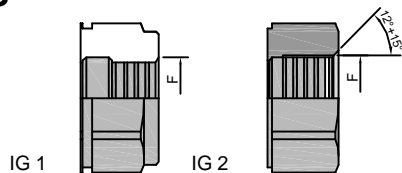

PLT1 DN39 - BG 7 - ISO 40

PLT1

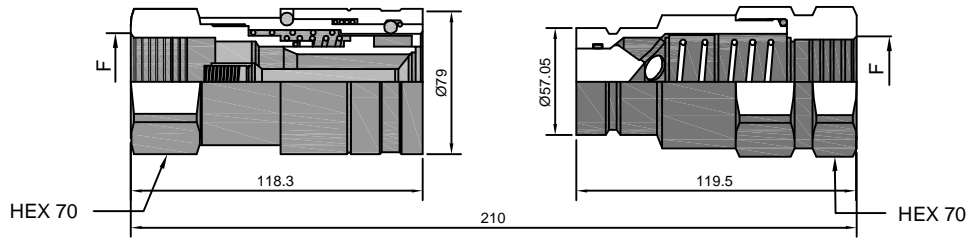

THREADS	F	STANDARD	FEMALE			MALE		
			COD.F	Weight (g)	Packaging (pcs.)	COD. M	Weight (g)	Packaging (pcs.)
IG 1	BSP 1"1/2	DIN 3852-2-X	PLT1.3939.002	2703	5	PLT1.3939.003	1879	10
	NPT 1"1/2	ANSI B1.20.3	PLT1.3939.012	2718	5	PLT1.3939.013	1893	10
IG 2	1"7/8-12 UN 2B	SAE J 1926-1	PLT1.3947.032	2680	5	PLT1.3947.033	1840	10

PLT1 DN50 - BG 8 - ISO 50

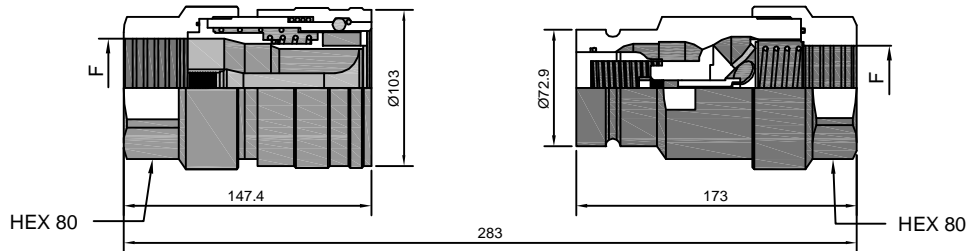

THREADS	F	STANDARD	FEMALE			MALE		
			COD.F	Weight (g)	Packaging (pcs.)	COD. M	Weight (g)	Packaging (pcs.)
IG 1	BSP 2"	DIN 3852-2-X	PLT1.5051.112	5500	5	PLK4.5051.113	4890	6
	NPT 2"	ANSI B1.20.3	PLT1.5051.012	5400	5	PLK4.5051.013	4790	6
	1"1/2	SAE 3000	PLT1.5051.002	6440	5	PLK4.5051.003	5830	6
IG 2	2"1/2-12 UN 2B	SAE J 1926-1	PLT1.5051.032	5300	5	PLK4.5051.033	4780	6

THREADS

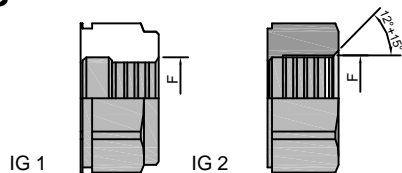

Nominal Size				Max working pressure	Rated Flow	Max flow rate	Min burst pressure			Fluid spillage
DPN	BG	ISO	mm				Male	Female	Coupled	
04	0	5	4	50	3	9	250	210	250	0.006
06	1	6.3	6	40	12	24	190	190	190	0.008
13	2	10	8.6	35	23	46	150	170	160	0.010
20	3	12.5	10.7	35	45	90	170	150	170	0.012
22	4A	16	12.8	35	74	150	160	140	150	0.015
25	4	19	14.8	35	100	200	160	140	180	0.020
30	5	25	17.6	35	189	280	140	140	150	0.030

S1 MPa = 145.04 psi • 1 l = 0.264 gal

Technical data

- Standard : ISO 16028
- Occlusion : flat face
- Locking : radial balls
- Material : steel
- Finishing : Zn-Fe (Cr III) and Zn-Ni
- Threads : BSP-NPT-SAE-METRIC
- Standard seal : NBR and PU
- Working temperature : -25°C+100°C
- Optional seals : FKM, EPDM or more
- Working Pressure : 350-500 bar
- Connection under pressure : not allowed

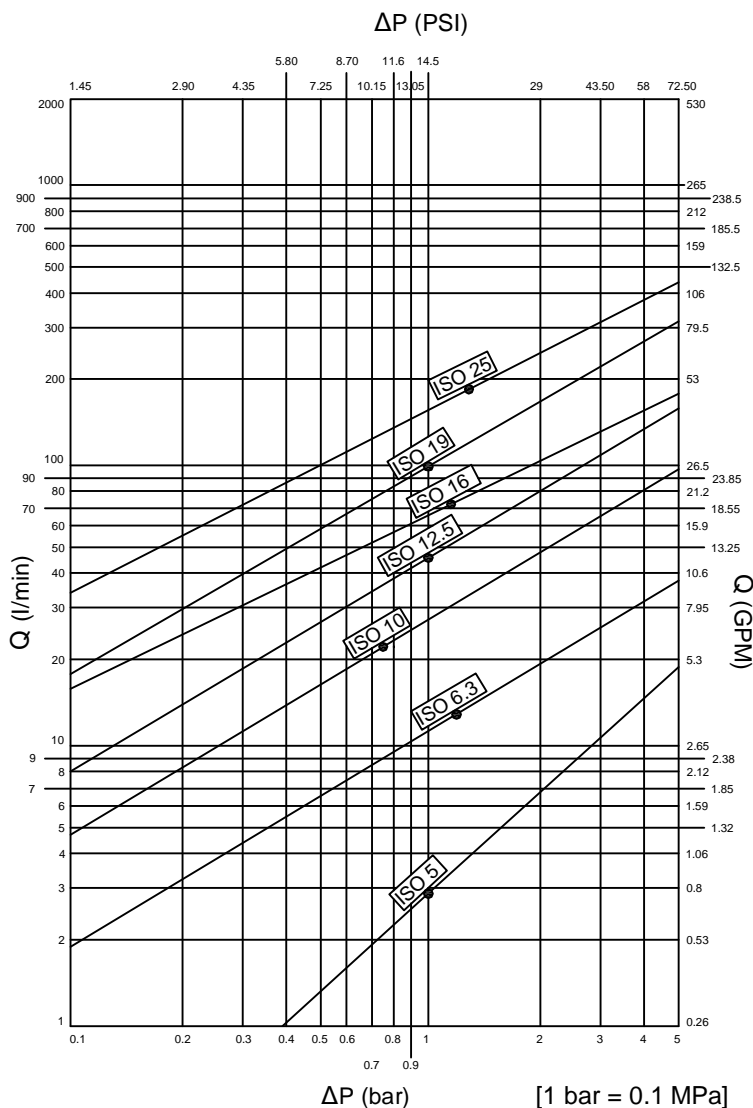

PLT4 DN04 - BG 0 - ISO 5

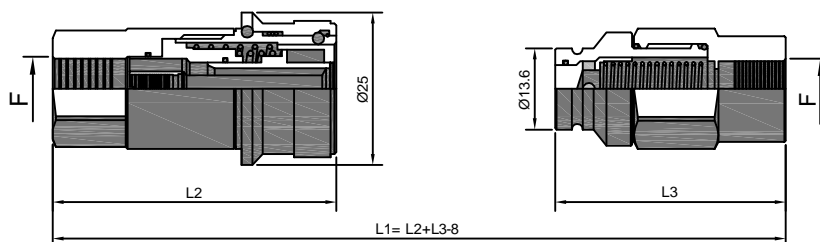

THREADS	L2	L3	F	STANDARD	FEMALE			MALE		
					COD.F	Weight (g)	Packaging (pcs.)	COD. M	Weight (g)	Packaging (pcs.)
IG 1	48.6	43.5	BSP 1/4"	DIN 3852-2-X	PLT1.0606.002	181	100	PLT1.0606.003	96	200
	48.6	43.5	NPT 1/4"	ANSI B1.20.3	PLT1.0606.012	181	100	PLT1.0606.013	96	200
IG2	50.6	45.5	7/16"-20 UNF 2B	SAE J 1926-1	PLT4.0412.032	94	192	PLT4.0412.033	53	300

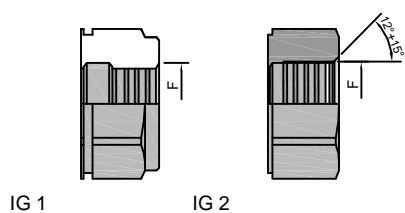

PLT4 DN06 - BG 1 - ISO 6.3

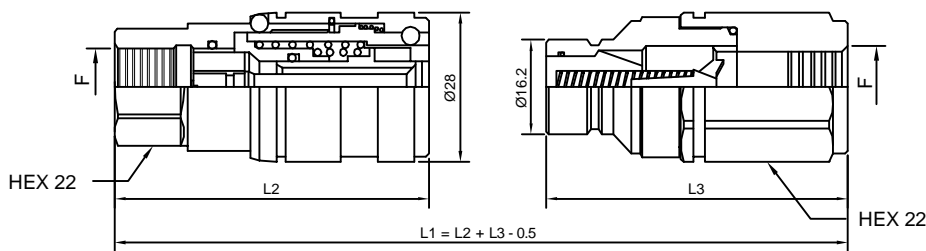

THREADS	L2	L3	L4	ØT	F	STANDARD	FEMALE			MALE		
							COD.F	Weight (g)	Packaging (pcs.)	COD. M	Weight (g)	Packaging (pcs.)
IG 1	58.5	52			BSP 1/4"	DIN 3852-2-X	PLT4.0606.112	181	100	PLT4.0606.113	95	200
	58.5	52			NPT 1/4"	ANSI B1.20.3	PLT4.0606.012	182	100	PLT4.0606.013	96	200
	58.5	52			BSP 3/8"	DIN 3852-2-X	PLT4.0610.112	170	100	PLT4.0610.113	86	200
	58.5	52			NPT 3/8"	ANSI B1.20.3	PLT4.0610.012	173	100	PLT4.0610.013	88	200
	58.5	52			M16x1.5	ISO 6149-1	PLT4.0616.102	173	100	PLT4.0616.103	89	200
	58.5	52			M18x1.5	ISO 6149-1	PLT4.0618.102	166	100	PLT4.0618.103	82	200
IG 2	58.5	52			9/16"-18 UNF 2B	SAE J 1926-1	PLT4.0615.32	178	100	PLT4.0615.033	92	200
AG 7	63.5	53.8	14		NPT 1/4"	ANSI B1.20.3	PLT4.0606.022	169	100	PLT4.0606.023	82	200
	63.5	53.8	14		R 1/4" - 19	UNI ISO 7/1	PLT4.0606.042	168	100	PLT4.0606.043	82	200
	63	53.8	14		NPT 3/8"	ANSI B1.20.3	PLT4.0610.022	173	100	PLT4.0610.023	90	200
AG 5	64	54.3	12		BSP 3/8"	DIN 3852-2-B	PLT4.0610.212	202	100	PLT4.0610.213	88	200
	63.5	53.8	12		BSP 1/4"	DIN 3852-2-A	PLT4.0606.712	172	100	PLT4.0606.713	83	200
	64	54.3	12		BSP 3/8"	DIN 3852-2-A	PLT4.0610.712	202	100	PLT4.0610.713	88	200
AG 2	63.6	53.9	14.1		9/16"-18 UNF 2A	SAE J 514	PLT4.0615.302	194	100	PLT4.0615.303	80	200
AGS 2	82.8	73.1	33.3		9/16"-18 UNF 2A	SAE J 514	PLT4.0615.502	181	70	PLT4.0615.503	93	150
AG 3	59.5	49.8	10	06L	M12x1.5	ISO 8434-1-L	PLT4.0612.302	165	100	PLT4.0612.303	77	200
	59.5	49.8	10	08L	M14x1.5	ISO 8434-1-L	PLT4.0614.302	166	100	PLT4.0614.303	78	200
	60.5	50.8	11	10L	M16x1.5	ISO 8434-1-L	PLT4.0616.302	168	100	PLT4.0616.303	79	200
	60.5	50.8	11	12L	M18x1.5	ISO 8434-1-L	PLT4.0618.302	168	100	PLT4.0618.303	80	200
	61.5	51.8	12	08S	M16x1.5	ISO 8434-1-S	PLT4.0616.402	171	100	PLT4.0616.403	83	200
	61.5	51.8	12	10S	M18x1.5	ISO 8434-1-S	PLT4.0618.402	173	100	PLT4.0618.403	85	200
AGS 3	75.5	65.8	26	06L	M12x1.5	ISO 8434-1-L	PLT4.0612.502	182	70	PLT4.0612.503	94	150
	75.5	65.8	26	08L	M14x1.5	ISO 8434-1-L	PLT4.0614.502	186	70	PLT4.0614.503	98	150
	75.5	65.8	26	10L	M16x1.5	ISO 8434-1-L	PLT4.0616.502	193	70	PLT4.0616.503	104	150
	75.5	65.8	26	12L	M18x1.5	ISO 8434-1-L	PLT4.0618.502	196	70	PLT4.0618.503	109	150
	76.5	66.8	27	08S	M16x1.5	ISO 8434-1-S	PLT4.0616.602	199	70	PLT4.0616.603	112	150
	76.5	66.8	27	10S	M18x1.5	ISO 8434-1-S	PLT4.0618.602	207	70	PLT4.0618.603	119	150
	76.5	66.8	27	12S	M20x1.5	ISO 8434-1-S	PLT4.0620.602	217	70	PLT4.0620.603	128	150

THREADS

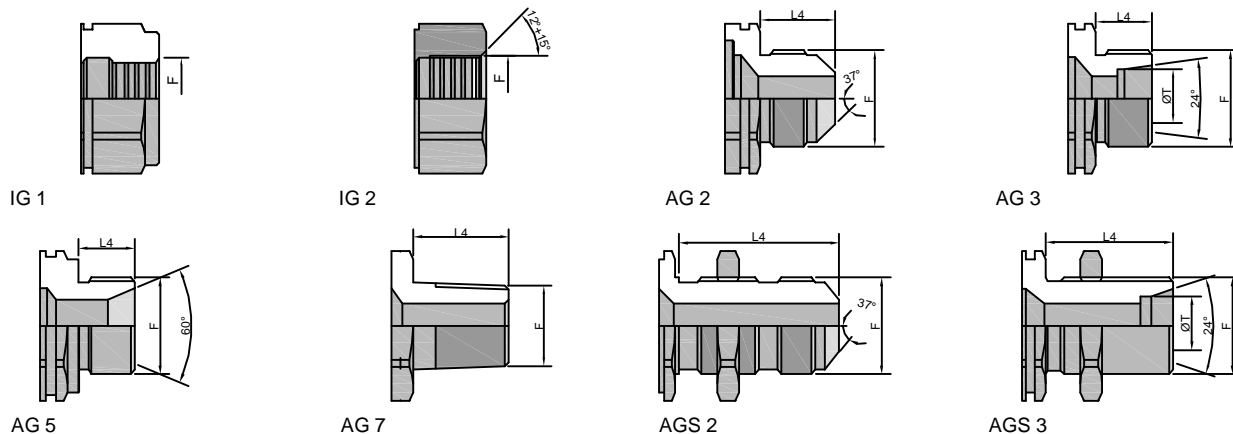

PLT4 DN13 - BG 2 - ISO 10

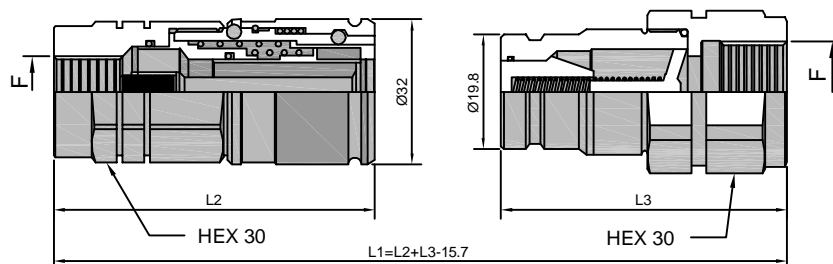

THREADS	L2	L3	L4	ØT	F	STANDARD	FEMALE			MALE		
							COD.F	Weight (g)	Packaging (pcs.)	COD. M	Weight (g)	Packaging (pcs.)
IG 1	73.5	60.5			BSP 1/4"	DIN 3852-2-X	PLT4.1306.112	319	60	PLT4.1306.113	168	60
	73.5	60.5			BSP 3/8"	DIN 3852-2-X	PLT4.1310.112	309	60	PLT4.1310.113	158	60
	73.5	60.5			NPT 3/8"	ANSI B1.20.3	PLT4.1310.012	311	60	PLT4.1310.013	184	60
	73.5	60.5			BSP 1/2"	DIN 3852-2-X	PLT4.1313.112	294	60	PLT4.1313.113	154	60
	73.5	60.5			NPT 1/2"	ANSI B1.20.3	PLT4.1313.012	297	60	PLT4.1313.013	168	60
	73.5	60.5			M14x1.5	ISO 6149-1	PLT4.1314.102	317	60	PLT4.1314.103	167	60
	73.5	60.5			M16x1.5	ISO 6149-1	PLT4.1316.102	312	60	PLT4.1316.103	162	60
	73.5	60.5			M18x1.5	ISO 6149-1	PLT4.1318.102	305	60	PLT4.1318.103	155	60
IG 2	72	60.5			9/16"-18 UNF 2B	SAE J 1926-1	PLT4.1315.032	309	60	PLT4.1315.033	165	60
	73.5	60.5			3/4"-16 UNF 2B	SAE J 1926-1	PLT4.1319.032	301	60	PLT4.1319.033	160	60
	74.5	64.5			7/8"-14 UNF 2B	SAE J 1926-1	PLT4.1323.032	287	60	PLT4.1323.033	159	60
	74.5	62.5			M16x1.5	SAE J 2244/1	PLT4.1316.112	311	60	PLT4.1316.113	175	60
AG 7	76.5	62.5	14		NPT 3/8"	ANSI B1.20.3	PLT4.1310.022	289	60	PLT4.1310.023	143	60
	74.5	60.5	13		M14x1.5	ISO 6149-2	PLT4.1314.222	286	60	PLT4.1314.223	134	60
AG 5	77.5	63.5	16		M20x1.5	ISO 6149-2	PLT4.1320.222	297	60	PLT4.1320.223	145	60
	77	62	12		BSP 3/8"	DIN 3852-2-B	PLT4.1310.212	293	60	PLT4.1310.213	136	60
	79	64.5	13		BSP 1/2"	DIN 3852-2-B	PLT4.1313.212	303	60	PLT4.1313.213	144	60
	74	58.5	11		M16x1.5	DIN 3863-U	PLT4.1316.702	283	60	PLT4.1316.703	128	60
	76	63.5	16		M20x1.5	DIN 3863-U	PLT4.1320.702	293	60	PLT4.1320.703	141	60
AG 2	77.1	61.6	14.1		9/16"-18 UNF 2A	SAE J 514	PLT4.1315.302	283	60	PLT4.1315.303	126	60
	79.7	64.2	16.7		3/4"-16 UNF 2A	SAE J 514	PLT4.1319.302	291	60	PLT4.1319.303	139	60
AGS 2	100.6	85.1	37.6		3/4"-16 UNF 2A	SAE J 514	PLT4.1319.502	315	60	PLT4.1319.503	162	60
	104.1	88.6	41.1		7/8"-46 UNF 2A	SAE J 514	PLT4.1323.502	330	60	PLT4.1323.503	178	60
AG 3	72.5	57.5	10	Ø8L	M14x1.5	ISO 8434-1-L	PLT4.1314.302	278	60	PLT4.1314.303	126	60
	73.5	58.5	11	10L	M16x1.5	ISO 8434-1-L	PLT4.1316.302	279	60	PLT4.1316.303	127	60
	73.5	58.5	11	12L	M18x1.5	ISO 8434-1-L	PLT4.1318.302	280	60	PLT4.1318.303	125	60
	74.5	59.5	12	15L	M22x1.5	ISO 8434-1-L	PLT4.1322.302	286	60	PLT4.1322.303	130	60
	74.5	59.5	12	18L	M26x1.5	ISO 8434-1-L	PLT4.1326.302	301	60	PLT4.1326.303	138	60
	74.5	59.5	12	10S	M18x1.5	ISO 8434-1-S	PLT4.1318.402	285	60	PLT4.1318.403	133	60
	74.5	59.5	12	12S	M20x1.5	ISO 8434-1-S	PLT4.1320.402	288	60	PLT4.1320.403	135	60
	76.5	61.5	14	14S	M22x1.5	ISO 8434-1-S	PLT4.1322.502	293	60	PLT4.1322.503	140	60
	76.5	61.5	14	16S	M24x1.5	ISO 8434-1-S	PLT4.1324.402	296	60	PLT4.1324.403	141	60
	AGS 3	88.5	73.5	26	Ø8L	M14x1.5	ISO 8434-1-L	PLT4.1314.502	297	60	PLT4.1314.503	146
88.5		73.5	26	10L	M16x1.5	ISO 8434-1-L	PLT4.1316.502	304	60	PLT4.1316.503	152	60
88.5		73.5	26	12L	M18x1.5	ISO 8434-1-L	PLT4.1318.502	309	60	PLT4.1318.503	153	60
98.5		83.5	36	12L	M18x1.5	ISO 8434-1-L	PLT4.1318.512	320	60	PLT4.1318.513	164	60
89.5		74.5	27	15L	M22x1.5	ISO 8434-1-L	PLT4.1322.502	334	60	PLT4.1322.503	179	60
89.5		74.5	27	18L	M26x1.5	ISO 8434-1-L	PLT4.1326.502	370	60	PLT4.1326.503	212	60
89.5		74.5	27	10S	M18x1.5	ISO 8434-1-S	PLT4.1318.602	319	60	PLT4.1318.603	167	60
89.5		74.5	27	12S	M20x1.5	ISO 8434-1-S	PLT4.1320.602	328	60	PLT4.1320.603	175	60
91.5		76.5	29	14S	M22x1.5	ISO 8434-1-S	PLT4.1322.602	345	60	PLT4.1322.603	194	60
91.5		76.5	29	16S	M24x1.5	ISO 8434-1-S	PLT4.1324.602	352	60	PLT4.1324.603	199	60

PLT4 DN20 - BG 3 - ISO 12.5

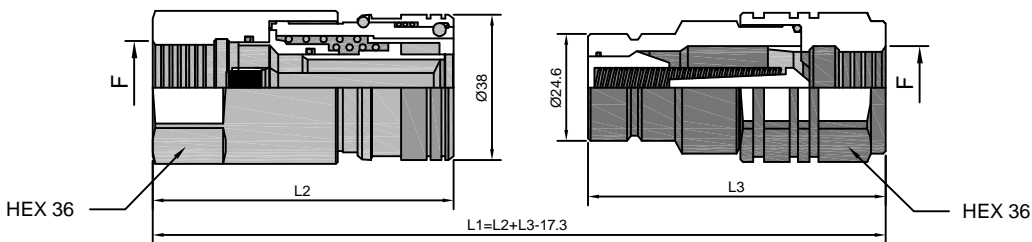

THREADS	L2	L3	L4	ØT	F	STANDARD	FEMALE			MALE		
							COD.F	Weight (g)	Packaging (pcs.)	COD. M	Weight (g)	Packaging (pcs.)
IG 1	83.5	72.5			BSP 1/2"	DIN 3852-2-X	PLT4.2013.112	529	35	PLT4.2013.113	301	42
	83.5	74			NPT 1/2"	ANSI B1.20.3	PLT4.2013.012	532	35	PLT4.2013.013	314	42
	83.5	74			RC 1/2"	UNI ISO 7/1	PLT4.2013.042	534	35	PLT4.2013.043	315	42
	83.5	74.5			BSP 3/4"	DIN 3852-2-X	PLT4.2019.112	498	35	PLT4.2019.113	282	42
	83.5	74			NPT 3/4"	ANSI B1.20.3	PLT4.2019.012	507	35	PLT4.2019.013	287	42
	83.5	74			RC 3/4"	UNI ISO 7/1	PLT4.2019.042	511	35	PLT4.2019.043	290	42
	82.5	70.5			M18x1.5	ISO 6149-1	PLT4.2018.102	534	35	PLT4.2018.103	300	42
	82.5	70			M22x1.5	ISO 6149-1	PLT4.2022.102	517	35	PLT4.2022.103	283	42
	83.5	74			M26x1.5	ISO 6149-1	PLT4.2026.102	496	35	PLT4.2026.103	280	42
83.5	74			M30x1.5	ISO 6149-1	PLT4.2030.102	470	35	PLT4.2030.103	254	42	
IG 2	79.5	70			3/4"-16 UNF 2B	SAE J 1926-1	PLT4.2019.032	507	35	PLT4.2019.033	293	42
	81.5	74			7/8"-14 UNF 2B	SAE J 1926-1	PLT4.2023.032	512	35	PLT4.2023.033	306	42
	83.5	74			1" 1/16-12 UN 2B	SAE J 1926-1	PLT4.2027.032	492	35	PLT4.2027.033	276	42
AG 2	92.5	81	22		1" 1/16-12 UN 2A	SAE J 514	PLT4.2027.302	470	35	PLT4.2027.303	272	42
AGS 2	111.6	100.1	41.1		7/8"-14 UNF 2A	SAE J 514	PLT4.2023.502	510	30	PLT4.2023.503	291	42
	115.9	104.4	45.4		1"1/16-12 UN 2A	SAE J 514	PLT4.2027.502	544	30	PLT4.2027.503	324	42
AG 5	89.5	78	16		BSP 3/4"	DIN 3852-2-A	PLT4.2019.712	477	35	PLT4.2019.713	273	42
AGS 4	109	97.5	38.5		1"-14 UNS 2A	SAE J 1453	PLT4.2025.532	539	30	PLT4.2025.533	323	42
AG 3	81.5	70	11	12L	M18x1.5	ISO 8434-1-L	PLT4.2018.302	453	35	PLT4.2018.303	239	42
	82.5	71	12	15L	M22x1.5	ISO 8434-1-L	PLT4.2022.302	458	35	PLT4.2022.303	244	42
	82.5	71	12	18L	M26x1.5	ISO 8434-1-L	PLT4.2026.302	466	35	PLT4.2026.303	250	42
	84.5	73	14	22L	M30x2	ISO 8434-1-L	PLT4.2030.302	468	35	PLT4.2030.303	254	42
	82.5	71	12	10L	M18x1.5	ISO 8434-1-S	PLT4.2018.402	460	35	PLT4.2018.403	243	42
	82.5	71	12	12S	M20x1.5	ISO 8434-1-S	PLT4.2020.402	462	35	PLT4.2020.403	246	42
	84.5	73	14	14S	M22x1.5	ISO 8434-1-S	PLT4.2022.402	466	35	PLT4.2022.403	250	42
	84.5	73	14	16S	M24x1.5	ISO 8434-1-S	PLT4.2024.402	469	35	PLT4.2024.403	252	42
	86.5	75	16	20S	M30x2	ISO 8434-1-S	PLT4.2030.402	481	35	PLT4.2030.403	267	42
AGS 3	96.5	85	26	12L	M18x1.5	ISO 8434-1-L	PLT4.2018.502	484	30	PLT4.2018.503	267	42
	97.5	86	27	15L	M22x1.5	ISO 8434-1-L	PLT4.2022.502	508	30	PLT4.2022.503	292	42
	97.5	86	27	18L	M26x1.5	ISO 8434-1-L	PLT4.2026.502	542	30	PLT4.2026.503	324	42
	104.5	93	34	22L	M30x2	ISO 8434-1-L	PLT4.2030.502	576	30	PLT4.2030.503	361	42
	97.5	86	27	10S	M18x1.5	ISO 8434-1-S	PLT4.2018.602	491	30	PLT4.2018.603	276	42
	97.5	86	27	12S	M20x1.5	ISO 8434-1-S	PLT4.2020.602	508	30	PLT4.2020.603	286	42
	99.5	88	29	14S	M22x1.5	ISO 8434-1-S	PLT4.2022.602	515	30	PLT4.2022.603	302	42
	99.5	88	29	16S	M24x1.5	ISO 8434-1-S	PLT4.2024.602	528	30	PLT4.2024.603	310	42
	104.5	93	34	20S	M30x2	ISO 8434-1-S	PLT4.2030.602	571	30	PLT4.2030.603	356	42

THREADS

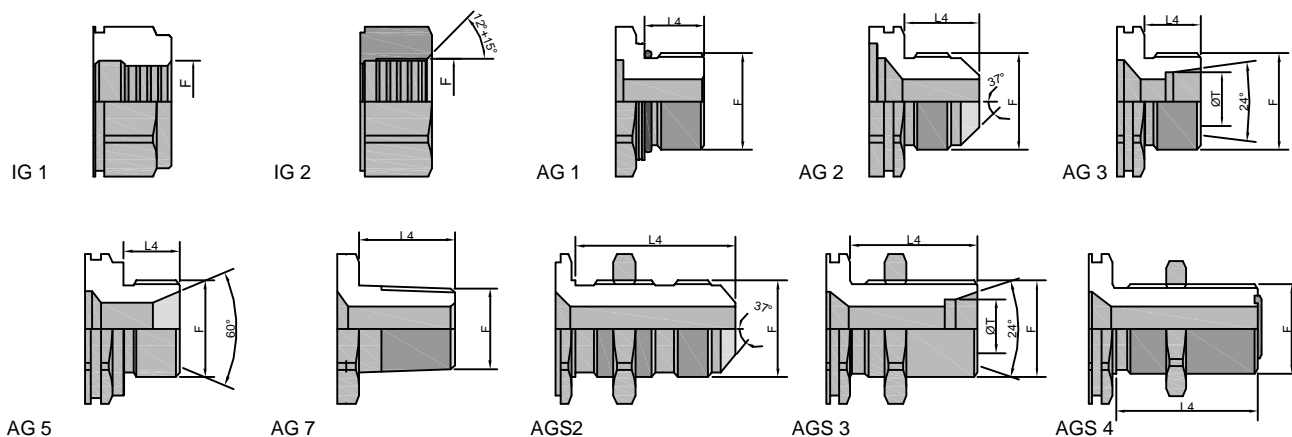

PLT4 DN22 - BG 4A - ISO 16

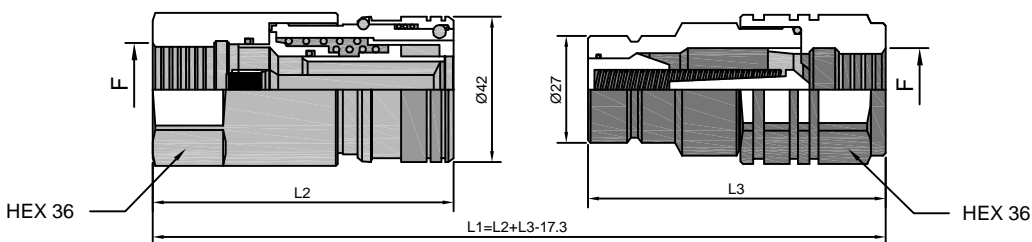

THREADS	L2	L3	L4	ØT	F	STANDARD	FEMALE			MALE		
							COD.F	Weight (g)	Packaging (pcs.)	COD. M	Weight (g)	Packaging (pcs.)
IG 1	86	72.5			BSP 1/2"	DIN 3852-2-X	PLT4.2213.112	576	30	PLT4.2213.113	326	42
	86	74			NPT 1/2"	ANSI B1.20.3	PLT4.2213.012	579	30	PLT4.2213.013	340	42
	86	74			RC 1/2"	UNI ISO 7/1	PLT4.2213.042	581	30	PLT4.2213.043	340	42
	86	74.5			BSP 3/4"	DIN 3852-2-X	PLT4.2219.112	545	30	PLT4.2219.113	307	42
	86	74			NPT 3/4"	ANSI B1.20.3	PLT4.2219.012	553	30	PLT4.2219.013	312	42
	86	74			RC 3/4"	UNI ISO 7/1	PLT4.2219.042	558	30	PLT4.2219.043	315	42
	85	70.5			M18x1.5	ISO 6149-1	PLT4.2218.102	580	30	PLT4.2218.103	325	42
	85	70			M22x1.5	ISO 6149-1	PLT4.2222.102	563	30	PLT4.2222.103	308	42
	86	74			M26x1.5	ISO 6149-1	PLT4.2226.102	542	30	PLT4.2226.103	305	42
86	74			M30x1.5	ISO 6149-1	PLT4.2230.102	516	30	PLT4.2230.103	279	42	
IG 2	82	70			3/4"-16 UNF 2B	SAE J 1926-1	PLT4.2219.032	553	30	PLT4.2219.033	318	42
	84	74			7/8"-14 UNF 2B	SAE J 1926-1	PLT4.2223.032	558	30	PLT4.2223.033	331	42
	86	74			1" 1/16-12 UN 2B	SAE J 1926-1	PLT4.2227.032	538	30	PLT4.2227.033	301	42
AG 2	95	81	22		1" 1/16-12 UN 2A	SAE J 514	PLT4.2227.302	516	30	PLT4.2227.303	297	42
AGS 2	114.1	100.1	41.1		7/8"-14 UNF 2A	SAE J 514	PLT4.2223.502	557	30	PLT4.2223.503	316	42
	118.4	104.4	45.4		1"1/16-12 UN 2A	SAE J 514	PLT4.2227.502	591	30	PLT4.2227.503	349	42
AG 5	90	78	16		BSP 3/4"	DIN 3852-2-A	PLT4.2219.712	524	30	PLT4.2219.713	298	42
AGS 4	111.5	97.5	38.5		1"-14 UNS 2A	SAE J 1453	PLT4.2225.532	586	30	PLT4.2225.533	348	42
AG 3	84	70	11	12L	M18x1.5	ISO 8434-1-L	PLT4.2218.302	500	30	PLT4.2218.303	264	42
	85	71	12	15L	M22x1.5	ISO 8434-1-L	PLT4.2222.302	505	30	PLT4.2222.303	269	42
	85	71	12	18L	M26x1.5	ISO 8434-1-L	PLT4.2226.302	513	30	PLT4.2226.303	275	42
	87	73	14	22L	M30x2	ISO 8434-1-L	PLT4.2230.302	515	30	PLT4.2230.303	279	42
	85	71	12	10L	M18x1.5	ISO 8434-1-S	PLT4.2218.402	506	30	PLT4.2218.403	268	42
	85	71	12	12S	M20x1.5	ISO 8434-1-S	PLT4.2220.402	509	30	PLT4.2220.403	271	42
	87	73	14	14S	M22x1.5	ISO 8434-1-S	PLT4.2222.402	513	30	PLT4.2222.403	275	42
	87	73	14	16S	M24x1.5	ISO 8434-1-S	PLT4.2224.402	516	30	PLT4.2224.403	277	42
	89	75	16	20S	M30x2	ISO 8434-1-S	PLT4.2230.402	528	30	PLT4.2230.403	292	42
	AGS 3	99	85	26	12L	M18x1.5	ISO 8434-1-L	PLT4.2218.502	530	30	PLT4.2218.503	293
100		86	27	15L	M22x1.5	ISO 8434-1-L	PLT4.2222.502	554	30	PLT4.2222.503	317	42
100		86	27	18L	M26x1.5	ISO 8434-1-L	PLT4.2226.502	588	30	PLT4.2226.503	349	42
107		93	34	22L	M30x2	ISO 8434-1-L	PLT4.2230.502	623	30	PLT4.2230.503	386	42
100		86	27	10S	M18x1.5	ISO 8434-1-S	PLT4.2218.602	538	30	PLT4.2218.603	301	42
100		86	27	12S	M20x1.5	ISO 8434-1-S	PLT4.2220.602	554	30	PLT4.2220.603	312	42
102		88	29	14S	M22x1.5	ISO 8434-1-S	PLT4.2222.602	562	30	PLT4.2222.603	327	42
102		88	29	16S	M24x1.5	ISO 8434-1-S	PLT4.2224.602	575	30	PLT4.2224.603	335	42
107		93	34	20S	M30x2	ISO 8434-1-S	PLT4.2230.602	618	30	PLT4.2230.603	381	42

THREADS

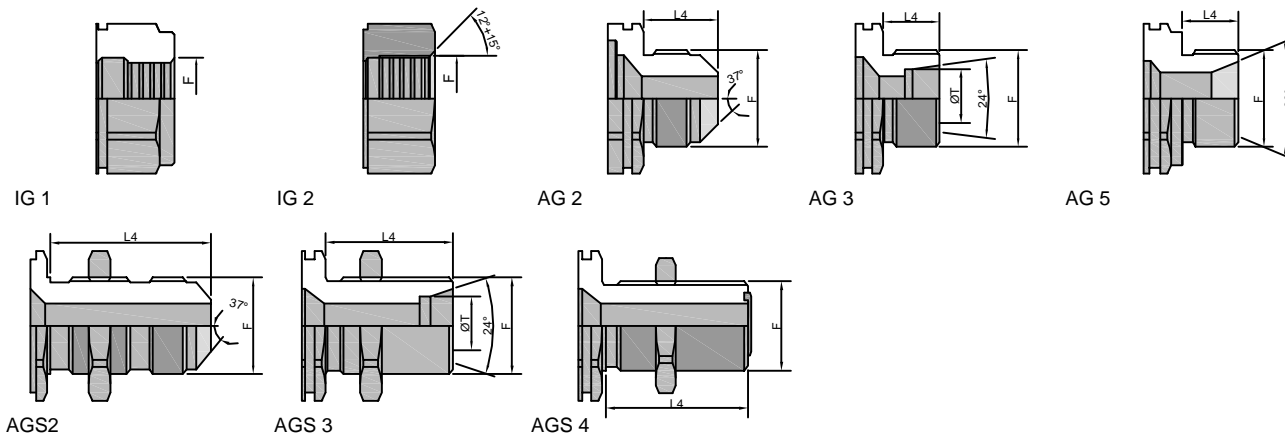

PLT4 DN25 - BG 4 - ISO 19

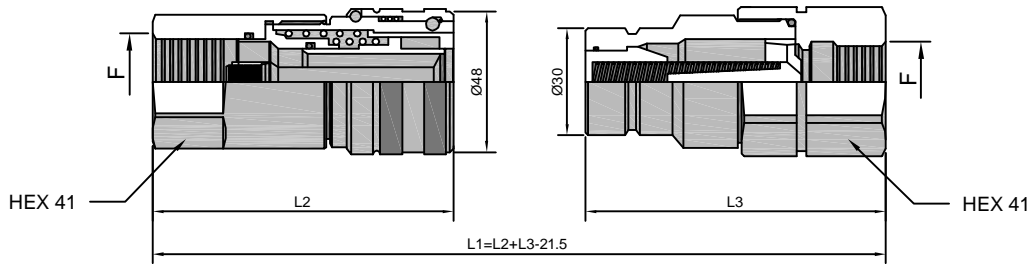

THREADS	L2	L3	L4	ØT	F	STANDARD	FEMALE			MALE		
							COD.F	Weight (g)	Packaging (pcs.)	COD. M	Weight (g)	Packaging (pcs.)
IG 1	94.5	86			BSP 3/4"	DIN 3852-2-X	PLT4.2519.112	808	23	PLT4.2519.113	478	30
	94.5	86			NPT 3/4"	ANSI B1.20.3	PLT4.2519.012	814	23	PLT4.2519.013	485	30
	97.5	86			BSP 1"	DIN 3852-2-X	PLT4.2525.112	780	23	PLT4.2525.113	419	30
	97.5	86			NPT 1"	ANSI B1.20.3	PLT4.2525.012	786	23	PLT4.2525.013	427	30
	97.5	86			M30x1.5	ISO 6149-1	PLT4.2530.102	810	23	PLT4.2530.103	450	30
IG 2	95	86			1"1/16-12 UN 2B	SAE J 1926-1	PLT4.2527.032	817	23	PLT4.2527.033	471	30
	95	86			1"5/16-12 UN 2B	SAE J 1926-1	PLT4.2533.032	758	23	PLT4.2533.033	413	30
AG 5	97	88	18		BSP 1"	DIN 3852-2-B	PLT4.2525.212	818	23	PLT4.2525.213	420	30
	95	84	17		BSP 1"	BS B5200	PLT4.2525.702	751	23	PLT4.2525.703	398	30
	95	86	16		BSP 3/4"	DIN 3852-2-A	PLT4.2519.712	749	23	PLT4.2519.713	396	30
	97	88	18		BSP 1"	DIN 3852-2-A	PLT4.2525.712	775	23	PLT4.2525.713	422	30
AG 3	97	79	12	18L	M26x1.5	ISO 8434-1-L	PLT4.2526.302	773	23	PLT4.2526.303	373	30
	99	81	14	22L	M30x2	ISO 8434-1-L	PLT4.2530.302	777	23	PLT4.2530.303	378	30
	99	81	14	28L	M36x2	ISO 8434-1-L	PLT4.2536.302	776	23	PLT4.2536.303	383	30
	101	83	16	20L	M30x2	ISO 8434-1-S	PLT4.2530.402	790	23	PLT4.2530.403	389	30
AGS 3	103	85	18	25L	M36x2	ISO 8434-1-S	PLT4.2536.402	807	23	PLT4.2536.403	412	30
	119	101	34	18L	M26x1.5	ISO 8434-1-L	PLT4.2526.502	864	23	PLT4.2526.503	461	30
	119	101	34	22L	M30x2	ISO 8434-1-L	PLT4.2530.502	882	23	PLT4.2530.503	486	30
	119	101	34	28L	M36x2	ISO 8434-1-L	PLT4.2536.502	910	23	PLT4.2536.503	524	30
	121	103	36	20L	M30x2	ISO 8434-1-S	PLT4.2530.602	902	23	PLT4.2530.603	503	30
123	105	39	25S	M36x2	ISO 8434-1-S	PLT4.2536.602	960	23	PLT4.2536.603	565	30	

PLT4 DN30 - BG 5 - ISO 25

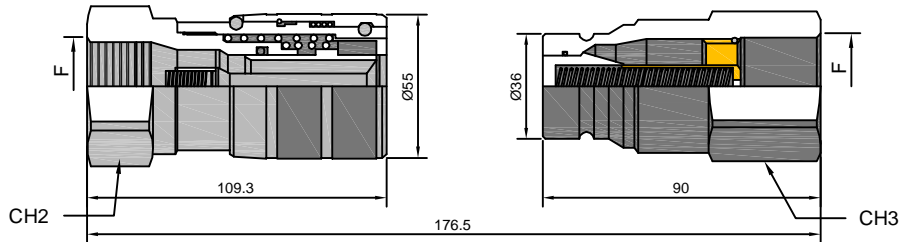

THREADS	L2	L3	F	STANDARD	FEMALE			MALE		
					COD.F	Weight (g)	Packaging (pcs.)	COD. M	Weight (g)	Packaging (pcs.)
IG 1	50	50	BSP 1"	DIN 3852-2-X	PLT4.3025.112	1236	7	PLT4.3025.113	726	18
	50	50	NPT 1"	ANSI B1.20.3	PLT4.3025.012	1260	7	PLT4.3025.013	733	18
	55	55	BSP 1"1/4	DIN 3852-2-X	PLT4.3031.112	1238	7	PLT4.3031.113	769	20
	55	55	NPT 1"1/4	ANSI B1.20.3	PLT4.3031.012	1253	7	PLT4.3031.013	781	20
IG 2	50	50	1"5/16-12 UN 2B	SAE J 1926-1	PLT4.3033.032	1235	7	PLT4.3033.033	715	20
	55	55	1"5/8-12 UN 2B	SAE J 1926-1	PLT4.3041.032	1241	7	PLT4.3041.033	768	20

THREADS

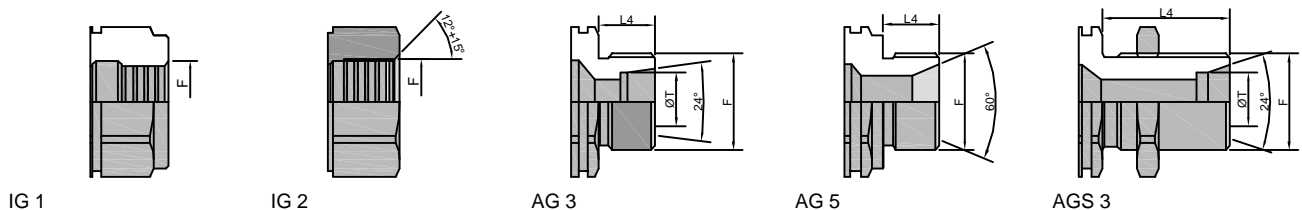

Nominal Size				Max working pressure	Rated Flow	Max flow rate	Min burst pressure			Fluid spillage
							Male	Female	Coupled	
DPN	BG	ISO	mm	MPa	l/min	l/min	MPa	Mpa	Mpa	cc
06	1	6.3	5	35	12	17	150	170	140	0.5
10	2	10	8.5	35	23	46	140	150	150	1.9
13	3	12.5	10.5	25	45	90	100	140	120	2.7
20	4	20	15.8	25	106	190	90	150	100	9.3
25	5	25	17.3	20	189	280	130	100	100	16
30	6	31.5	22.8	20	288	480	110	85	100	30
39	7	40	29.9	19	379	757	80	80	82	54
50	8	50	37.7	16	757	1000	65	96	100	120

1 MPa = 145.04 psi • 1 l = 0.264 gal

ΔP (PSI)

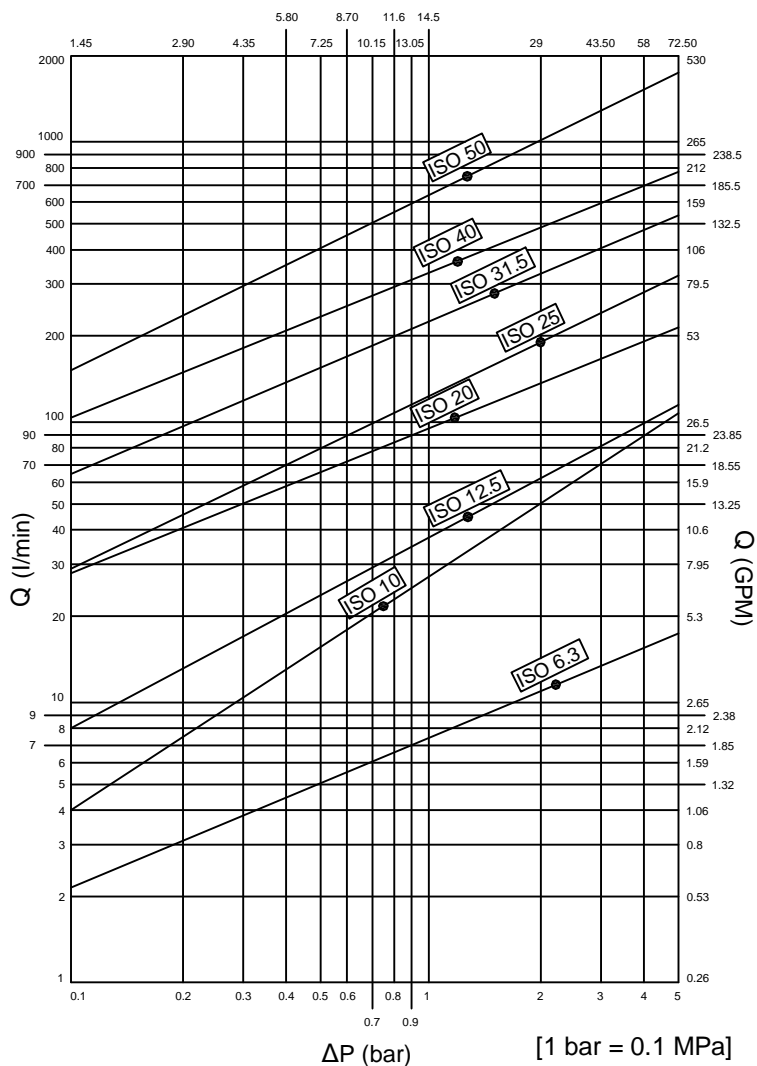

Technical data

- Standard : ISO 7241-1A
- Occlusion : poppet
- Locking : radial balls
- Material : steel
- Finishing : Zn-Fe (Cr III)
- Threads : BSP-NPT-RC-SAE
- Standard seal : NBR
- Working temperature : -25°C+100°C
- Optional seals : FKM, EPDM or more
- Working Pressure : 160-350 bar
- Connection under pressure : not allowed

PAV1 DN06 - BG 1 - ISO 6.3

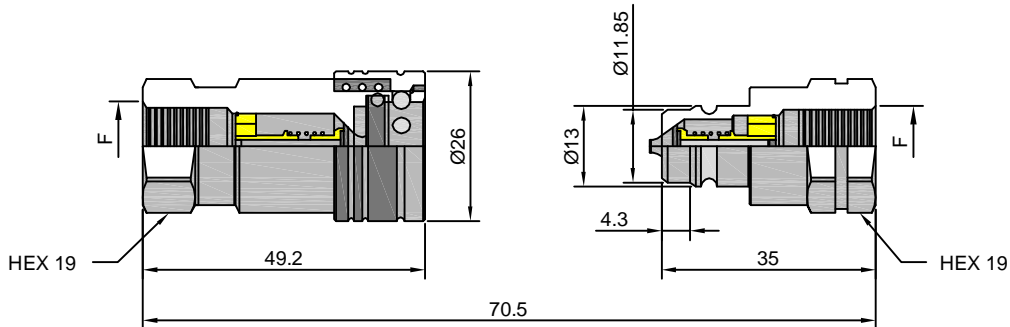

THREADS	F	STANDARD	FEMALE			MALE		
			COD.F	Weight (g)	Packaging (pcs.)	COD. M	Weight (g)	Packaging (pcs.)
IG 1	BSP 1/4"	DIN 3852-2-X	PAV1.0606.002	106	180	PAV1.0606.003	37	300
	NPT 1/4"	ANSI B1.20.3	PAV1.0606.012	107	180	PAV1.0606.013	38	300
	RC 1/4"	UNI ISO 7/1	PAV1.0606.042	107	180	PAV1.0606.043	38	300
IG2	9/16"-18 UNF 2B	SAE J 1926-1	PAV1.0615.032	102	180	PAV1.0615.033	34	300

PAV1 DN10 - BG 2 - ISO 10

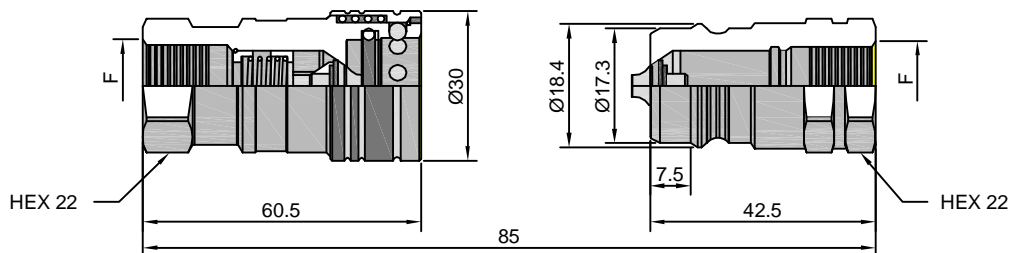

THREADS	F	STANDARD	FEMALE			MALE		
			COD.F	Weight (g)	Packaging (pcs.)	COD. M	Weight (g)	Packaging (pcs.)
IG 1	BSP 3/8"	DIN 3852-2-X	PAV1.1010.002	155	100	PAV1.1010.003	59	200
	NPT 3/8"	ANSI B1.20.3	PAV1.1010.012	156	100	PAV1.1010.013	60	200
	RC 3/8"	UNI ISO 7/1	PAV1.1010.042	156	100	PAV1.1010.043	60	200
IG2	9/16"-18 UNF 2B	SAE J 1926-1	PAV1.1015.032	175	100	PAV1.1015.033		
	3/4"-16 UNF 2B	SAE J 1926-1	PAV1.1019.032	184	100	PAV1.1019.033	63	200

THREADS

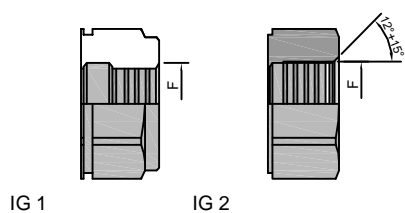

PAV1 DN13 - BG 3 - ISO 12.5

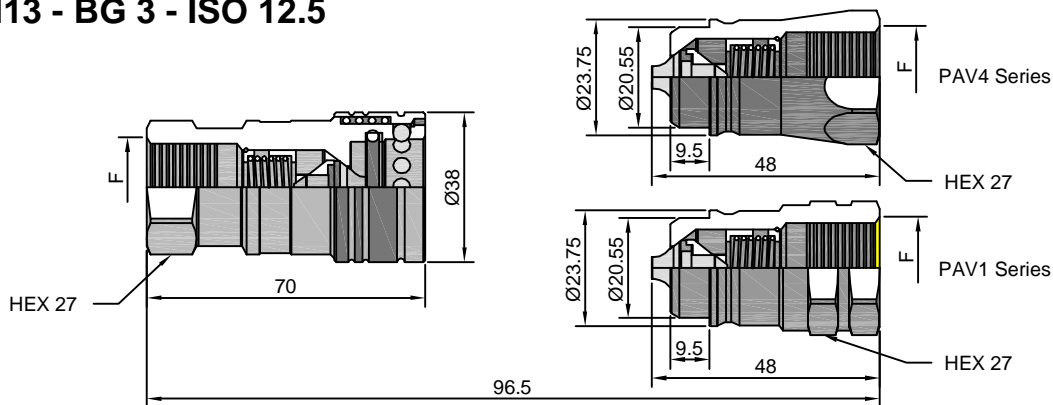

THREADS	F	STANDARD	FEMALE			MALE		
			COD.F	Weight (g)	Packaging (pcs.)	COD. M	Weight (g)	Packaging (pcs.)
IG 1	BSP 1/2"	DIN 3852-2-X	PAV1.1313.002	268	50	PAV1.1313.003	97	200
	BSP 1/2"	DIN 3852-2-X				PAV4.1313.003	94	200
	NPT 1/2"	ANSI B1.20.3	PAV1.1313.012	269	50	PAV1.1313.013	98	200
	RC 1/2"	UNI ISO 7/1	PAV1.1313.042	269	50	PAV1.1313.043	98	200
IG2	NPT 3/4"	ANSI B1.20.3	PAV1.1313.012	353	50			
	M22x1.5	SAE J 2244/1	PAV1.1322.102	260	50	PAV1.1322.103	90	200
	3/4"-16 UNF 2B	SAE J 1926-1	PAV1.1319.032	274	50	PAV4.1319.033	101	200
	7/8"-14 UNF 2B	SAE J 1926-1	PAV1.1323.032	260	50			

PAV6 DN13 - BG 3 - ISO 12.5

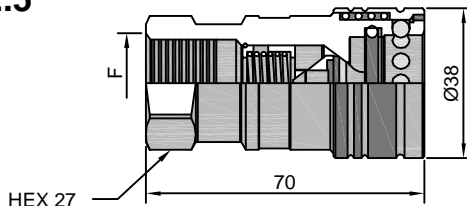

F	STANDARD	FEMALE			MALE		
		COD.F	Weight (g)	Packaging (pcs.)	COD. M	Weight (g)	Packaging (pcs.)
BSP 1/2"	DIN 3852-2-X	PAV6.1313.002	292	50	PAV6.1313.003		
NPT 1/2"	ANSI B1.20.3	PAV6.1313.012	294	50	PAV6.1313.013		

PAV1 DN20 - BG 4 - ISO 20

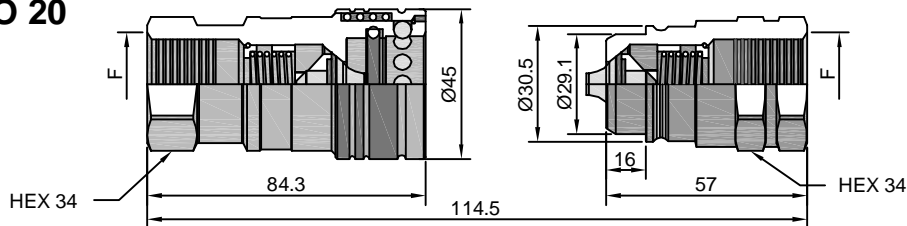

F	STANDARD	FEMALE			MALE		
		COD.F	Weight (g)	Packaging (pcs.)	COD. M	Weight (g)	Packaging (pcs.)
BSP 3/4"	DIN 3852-2-X	PAV1.2019.002	428	28	PAV1.2019.003	180	45
NPT 3/4"	ANSI B1.20.3	PAV1.2019.012	434	28	PAV1.2019.013	186	45
RC 3/4"	UNI ISO 7/1	PAV1.2019.042	434	28	PAV1.2019.043	186	45

THREADS

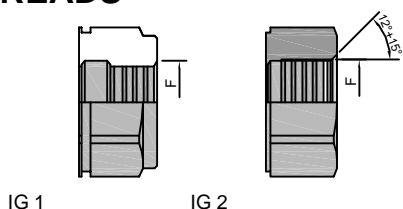

PAV1 DN25 - BG 5 - ISO 25

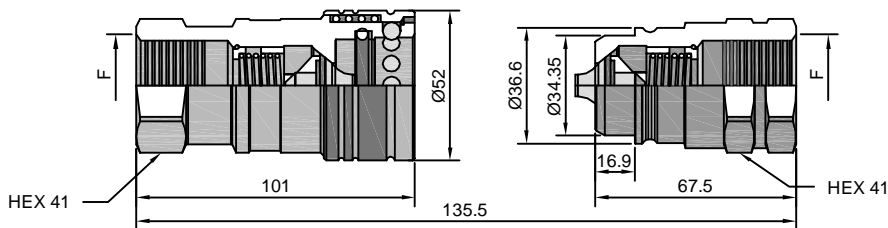

F	STANDARD	FEMALE			MALE		
		COD.F	Weight (g)	Packaging (pcs.)	COD. M	Weight (g)	Packaging (pcs.)
BSP 1"	DIN 3852-2-X	PAV1.2525.002	700	20	PAV1.2525.003	304	30
NPT 1"	ANSI B1.20.3	PAV1.2525.012	708	20	PAV1.2525.013	313	30
RC 1"	UNI ISO 7/1	PAV1.2525.042	708	20	PAV1.2525.043	313	30

PAV1 DN30 - BG 6 - ISO 31.5

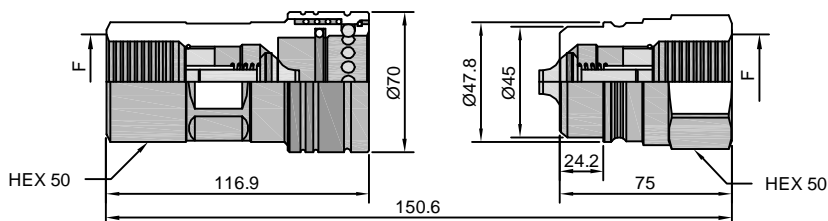

F	STANDARD	FEMALE			MALE		
		COD.F	Weight (g)	Packaging (pcs.)	COD. M	Weight (g)	Packaging (pcs.)
BSP 1" 1/4	DIN 3852-2-X	PAV1.3031.002	1515	12	PAV1.3031.003	559	20
NPT 1" 1/4	ANSI B1.20.3	PAV1.3031.012	1532	12	PAV1.3031.013	572	20
RC 1" 1/4	UNI ISO 7/1	PAV1.3031.042	1532	12	PAV1.3031.043	572	20

PAV1 DN39 - BG 7 - ISO 40

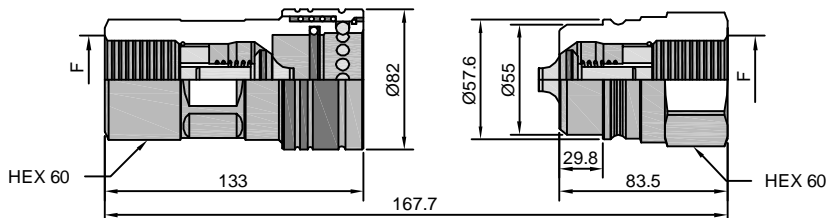

F	STANDARD	FEMALE			MALE		
		COD.F	Weight (g)	Packaging (pcs.)	COD. M	Weight (g)	Packaging (pcs.)
BSP 1" 1/2	DIN 3852-2-X	PAV1.3939.002	2445	8	PAV1.3939.003	918	12
NPT 1" 1/2	ANSI B1.20.3	PAV1.3939.012	2464	8	PAV1.3939.013	938	12
RC 1" 1/2	UNI ISO 7/1	PAV1.3939.042	2464	8	PAV1.3939.043	938	12

PAV1 DN50 - BG 8 - ISO 50

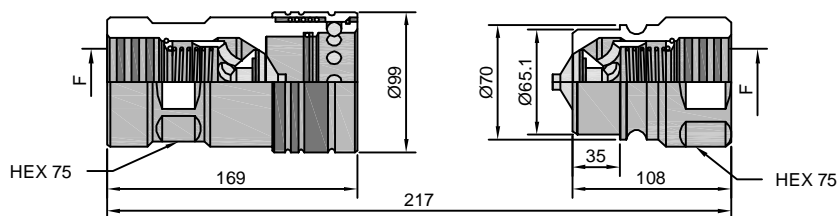

F	STANDARD	FEMALE			MALE		
		COD.F	Weight (g)	Packaging (pcs.)	COD. M	Weight (g)	Packaging (pcs.)
BSP 2"	DIN 3852-2-X	PAV1.5051.002	5000	5	PAV1.5051.003	1804	8
NPT 2"	ANSI B1.20.3	PAV1.5051.012	5010	5	PAV1.5051.013	1820	8
RC 2"	UNI ISO 7/1	PAV1.5051.042	5010	5	PAV1.5051.043	1820	8

Nominal Size				Max working pressure	Rated Flow	Max flow rate	Min burst pressure			Fluid spillage
DPN	BG	ISO	mm				Male	Female	Coupled	
06	1	6.3	3.7	70	5	10	150	200	220	0.2
10	2	10	4.8	70	9	20	150	200	220	0.6

1 MPa = 145.04 psi • 1 l = 0.264 gal

Technical data

- Standard : ISO 14540
- Occlusion : ball
- Locking : screw
- Material : steel
- Finishing : Zn-Fe (Cr III)
- Threads : BSP-NPT
- Standard seal : NBR
- Working temperature : -25°C+100°C
- Optional seals : FKM, EPDM or more
- Working Pressure : 700 bar
- Connection under pressure : allowed (both male or female side)
- Max residual pressure : 100 bar

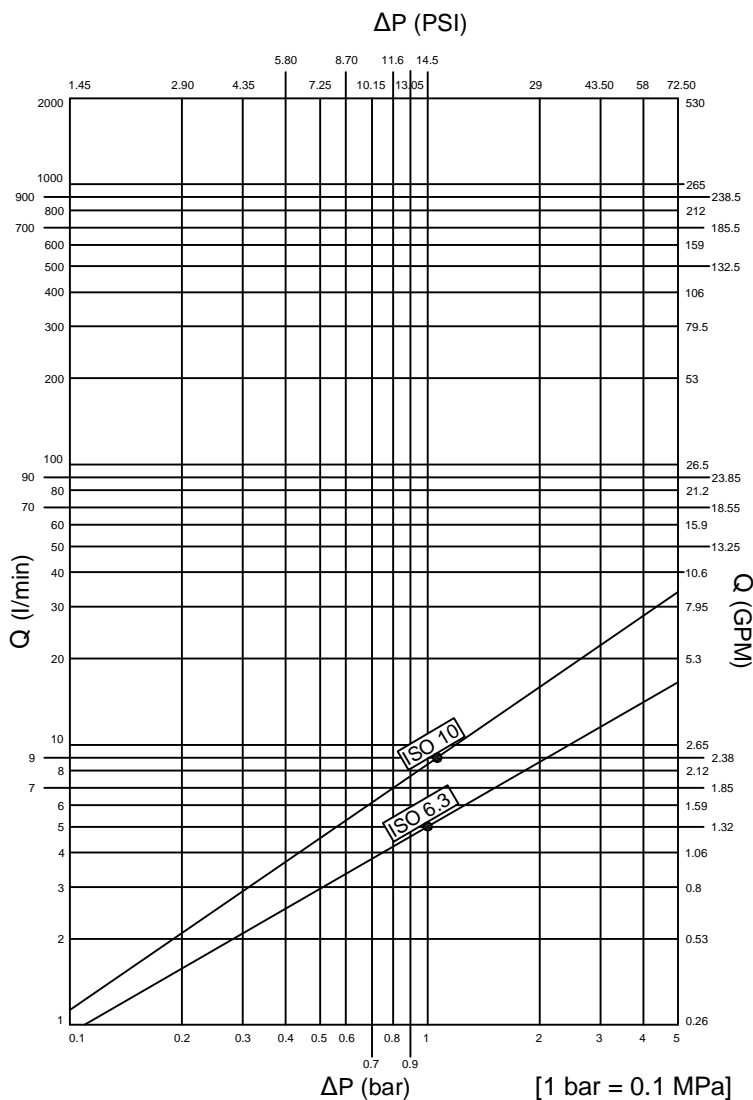

PVS DNO6 - BG 1 - ISO 6.3

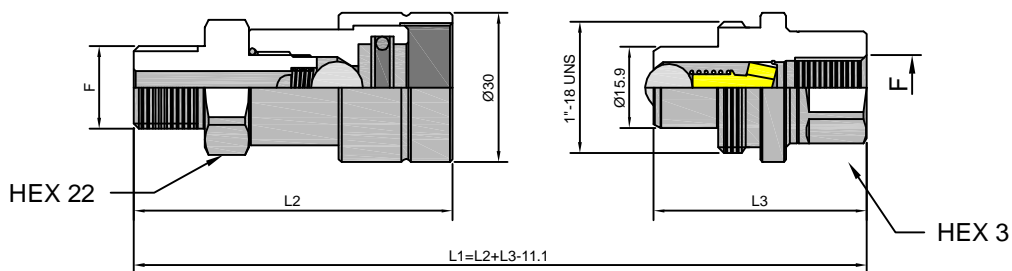

THREADS	L2	CH3	L3	L4	F	STANDARD	FEMALE			MALE		
							COD.F	Weight (g)	Packaging (pcs.)	COD. M	Weight (g)	Packaging (pcs.)
IG 1	56	19	39		NPT 1/4"	ANSI B1.20.3	PVS3.0606.012	162	100	PVS1.0606.113	87	120
		30	39		NPT 3/8"	ANSI B1.20.3				PVS1.0610.013	131	100
AG 7	49	19	54	10	NPT 1/8"	ANSI B1.20.3	PVS3.0604.022	127	100	PVS1.0604.023	115	120
	53	19	58	14	NPT 1/4"	ANSI B1.20.3	PVS3.0606.022	134	100	PVS1.0606.023	122	120
		19	73.5	14	NPT 1/4"	ANSI B1.20.3				PVS3.0606.023	150	72
	53			14	NPT 3/8"	ANSI B1.20.3	PVS3.0610.022	139	100			
AG 5	51.5			10.5	BSP 1/4"	JIS B8363	PVS3.0606.212	132	100			

PVS DN10 - BG 2 - ISO 10

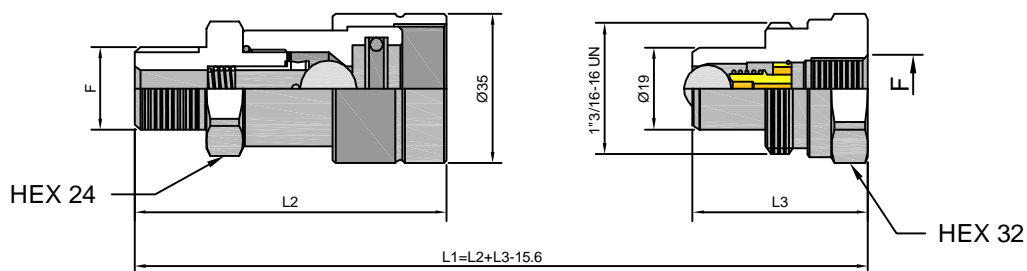

THREADS	L2	L3	L4	ØT	F	STANDARD	FEMALE			MALE		
							COD.F	Weight (g)	Packaging (pcs.)	COD. M	Weight (g)	Packaging (pcs.)
IG 1		40.5			NPT 1/4"	ANSI B1.20.3				PVS1.1006.013	165	100
	66.5	40.5			BSP 3/8"	DIN 3852-2-X	PVS3.1010.112	249	70	PVS1.1010.003	144	100
	66	40.5			NPT 3/8"	ANSI B1.20.3	PVS3.1010.012	250	70	PVS1.1010.013	145	100
		40.5			RC 3/8"	UNI ISO 7/1				PVS1.1010.043	145	100
AG 7	64.5		14		NPT 1/4"	ANSI B1.20.3	PVS3.1006.022	219	70			
	62	60.5	14		NPT 3/8"	ANSI B1.20.3	PVS3.1010.022	221	70	PVS3.1010.023	187	100
	62		14		R 3/8"	UNI ISO 7/1	PVS3.1010.042	222	70			
	67.5		19.5		R 1/2"	UNI ISO 7/1	PVS3.1013.042	246	70			
AG 6	64.5	63	12		BSP 3/8"	DIN 3852-11-E	PVS3.1010.232	231	70	PVS3.1010.023	200	100
AG 5	62.5		12		BSP 3/8"	DIN 3852-2-A	PVS3.1010.212	224	70			
	64.5	63	12		BSP 3/8"	DIN 3852-2-B	PVS3.1010.222	231	70	PVS3.1010.223	197	100
AG 3	62		12	10S	M18x1.5	ISO 8434-1-S	PVS3.1018.402	225	70			

THREADS

